

Security Products

Automatic Fire Detector in Conventional Technology

Detector Series FC600

Technical Data

- Detector series compliant to EN 54 comprising of smoke and heat detectors – VdS approved
- Alarm LED on the detector head
- Simple handling using bayonet connection
- Test activation possible using a magnet
- Anti-tamper mechanical block feature
- Remote indicator can be connected to the detector base



Description

The FC600 fire detector series are conventional threshold alarm detectors that comply with the respective standard of the EN 54 standard series and are VdS approved.

The detectors feature an alarm indicator on the detector head that is visible from all angles, and which can be triggered with a permanent magnet for test purposes. A detector base is provided for mounting and cable connection purposes, into which the detector is simply plugged-in via the bayonet connection. By connecting an address module to the detector base, the relevant detector can be identified by the alarm panel during an alarm, should the alarm panel have the respective performance features. In this case, the first detector that was triggered is detected for each detector group.

Application

The FC600 series offers detectors for different applications. The Optical Smoke Detector FC600/O operates according to the scattered-light principle and is used where smoke is expected in case of a fire. The detector is equipped with a dust barrier that protects the detector both against dust contamination as well as penetration of outside light sources. An insect screen prevents intrusion by small insects.

If factors such as dust, water vapour or cigarette smoke are expected to affect the smoke detector operation or very fast heat development is expected in the event of a fire, the Heat Detectors FC600/TDIFF or FC600/TMAX should be used. The Thermal Max. Detector FC600/TMAX triggers if a predefined threshold temperature of 78 °C is exceeded. The Thermal ROR Detector FC600/TDIFF also reacts to fast increase in temperature, which generally occur in the event of a fire, and at a temperature of 57 °C or higher. The temperature is monitored with so-called measuring thermistors.

All detectors are only intended for indoor use in dry ambience.

Automatic Fire Detector in Threshold Alarm Technology

Application

Two types of detector bases are available for connection and installation of the detectors. If the detectors are connected to a fire control panel, the base FC600/BR is used. When connecting using 4-wire technology, for example, to an Intrusion Alarm Panel or a KNX Zone Terminal, the relay base FC600/BREL should be used (see separate data sheet).

The resistor that triggers the alarm is soldered into the detector base ex-works. The end of line resistor is connected to the last base of a detector group in accordance with the connection schematic.

An LED on the detector head indicates the state of the detector. Optionally, a remote indicator (PA58-3) for remote signaling of an alarm can be connected to the detector base (see circuit diagram).

Should there be a requirement to hinder easy removal of the detector from the base, a small plastic peg on the side of the detector base can be broken off by inserting a solid object through the aperture on the detector base. Only after insertion at the same point, for example, of a screwdriver, is it possible to unlatch the detector and turn it out of the base (see "Unlatching the detector" illustration below).

Engineering

The number of detectors and the installation locations result from the engineering specifications for fire detectors VDE 0833 – part 2 and the engineering guidelines compliant to VdS 2095, should there be any insurance related requirements.

Electrical connection - circuit example with 3 detectors

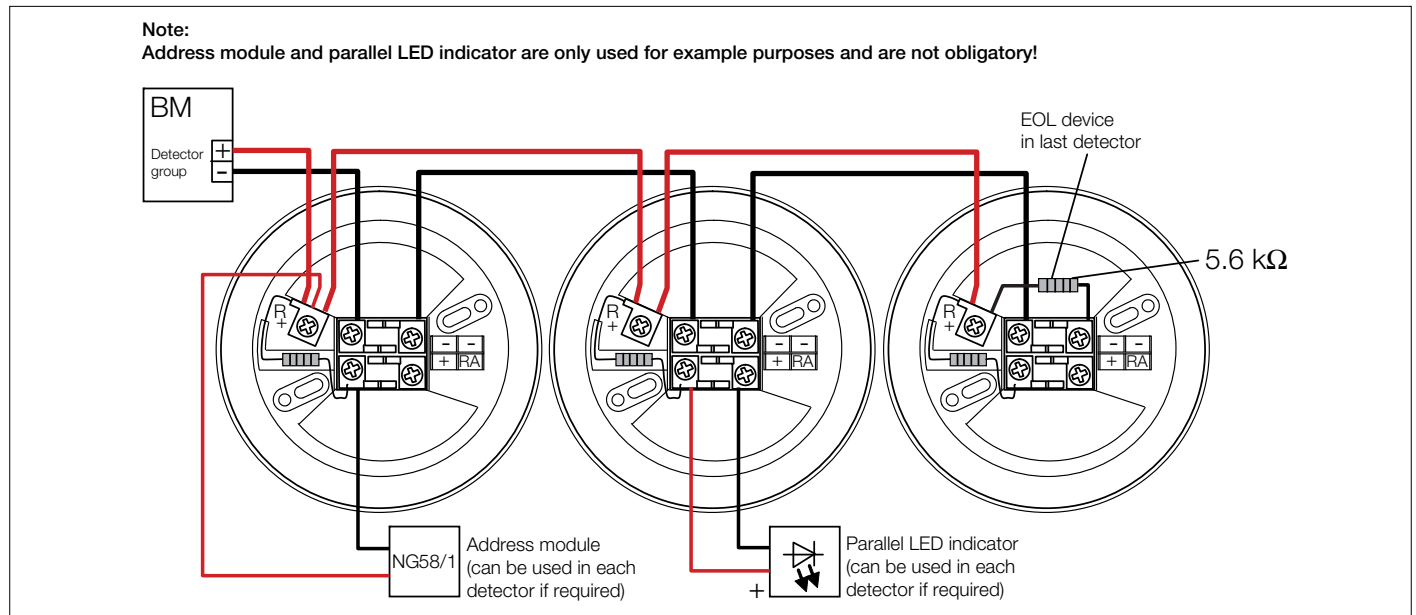

Unlatching the detector | Dimensional drawing

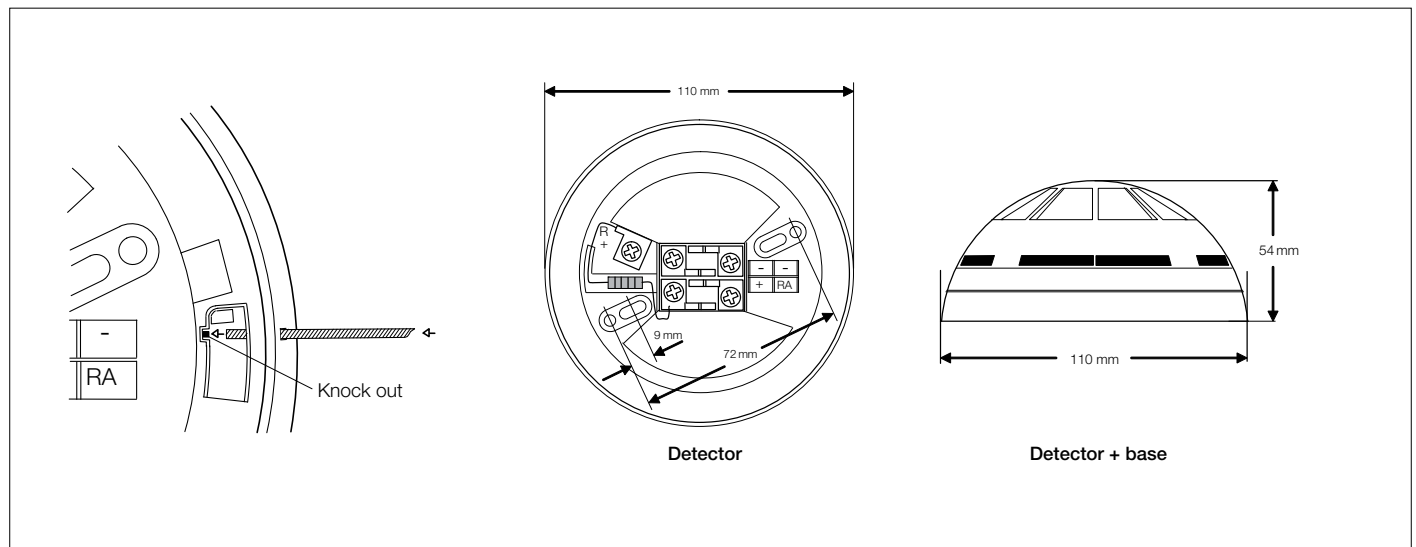

Automatic Fire Detector in Threshold Alarm Technology

Installation

The detector bases are fixed on the ceiling with 2 screws, after the corresponding preparations have been made. The detector is mounted horizontally as standard. The location of the mounting bores can be found in the "Dimensional drawing" section.

During installation, it is important to ensure that the base does not warp when installed on an uneven ceiling, as it may make it difficult or impossible to plug-in the detector. The detector is placed against the base and screwed onto the base in a clockwise direction.

Cable connection

With flush-mounted cabling, it is necessary to ensure that all the required conductors for standard wiring are located on the "R+" terminal side. The incoming and outgoing conductors can be inserted through the same aperture on the socket base (also see the dimensional drawing).

With flush-mounted cabling, it is also advantageous if both cables are inserted on the side of the base, where the terminal "R+" and the terminals for all other standard applications are located.

When introducing the cable from 2 sides, the location of the base should be selected, so that the breaking points for the cable entry on the base are offset longitudinally to the cable path by 180°. The individual wires can be fed both within the base interior as well as from underneath the base, from one half of the base to the other. Cables up to 2 x 2 x 0.8 mm can be inserted to the base together with the sheath; thicker cables will require removal of the sheath outside the base. If the cable shield (sheath wire) of incoming and outgoing cables is to be looped through, this must be implemented in the base, e.g. using a ferrule or similar device.

Test activation

A test activation can be undertaken by holding a permanent magnet at the smoke inlet aperture level (these are also available on the heat detectors) located at about 100° in a counter-clockwise orientation starting from the rectangular opening on the side of the detector base on the detector.

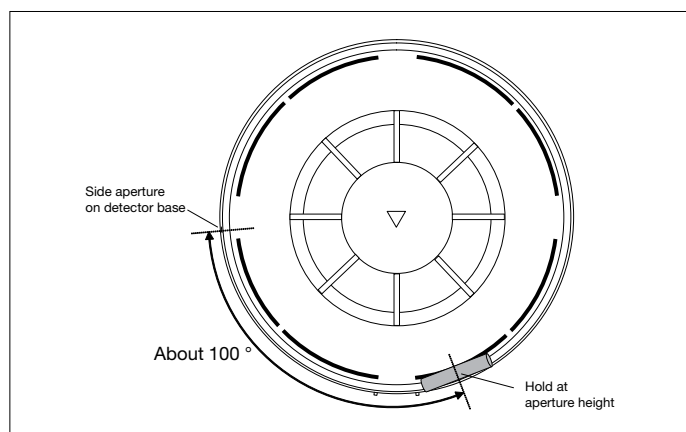

Inspection/Maintenance

Every detector must be physically activated at least once a year to test its function in accordance with VDE 0833 part 1. A suitable testing aerosol is recommended for activation of smoke detectors; heat detectors should be activated using a heat gun or a hair drier.

Technical Data

Electrical values

Operating voltage	10 to 30 V DC
Quiescent current consumption	
FC600/O	Typ. 75 µA, at typ. 24 V DC line voltage and 25 °C
FC600/TMAX-TDIFF	Typ. 40 µA, at typ. 24 V DC line voltage and 25 °C
Alarm current	Max. 50 mA, limited by alarm resistor in detector base (do not short-circuit)

General data

Temperature range	-30 °C to +70 °C
Application temperature	Max. 45 °C (FC600/TDIFF) Max. 60 °C (FC600/TMAX)
Activation temperature	57 °C (FC600/TDIFF) 78 °C (FC600/TMAX)
Air humidity	Max. 95 % relative (without condensation)
Enclosure	IP30
Manufacturing date	Label on detector base
Dimensions W x H	
Detector	106 mm x 46 mm
Base	110 mm x 16 mm
Detector + Base	110 mm x 54 mm
Weight	Approx. 80 g
Colour	White
Material	Plastic
Approvals	
FC600/O	VdS No. G 209200
FC600/TMAX	VdS No. G 209199
FC600/TDIFF	VdS No. G 209198
Applicable standard	
FC600/O	EN 54-7
FC600/TMAX	EN 54-5 – class BS
FC600/TDIFF	EN 54-5 – class A1R

Specifications according to Building Products Act



09

0832-CPD-0125 FC600/O

0832-CPD-0126 FC600/TMAX

0832-CPD-0127 FC600/TDIFF

EN54-7:2000 + A1:2002

Smoke detectors - Point detectors using scattered light

EN54-5:2000 + A1:2002

Heat detectors - Point detectors

Automatic Fire Detector in Threshold Alarm Technology

Ordering Information

Product photo	Description	Short designation	Order code	bbn 40 16779 EAN	Price group	Weight 1 pcs kg	Pack unit Quantity
	Optical Smoke Detector VdS No. G 209200	FC600/O	2CDG 430 047 R0011	70836 4	P6	0.07	1
	Static Heat Detector VdS No. G 209199	FC600/TMAX	2CDG 430 049 R0011	70838 8	P6	0.07	1
	Thermal ROR Detector VdS No. G 209198	FC600/TDIFF	2CDG 430 048 R0011	70837 1	P6	0.07	1
	Universal Detector Base for Series FC600	FC600/BR	2CDG 430 050 R0011	70839 5	P6	0.04	1
	Detector Base 12/24 V	FC600/BREL	2CDG 430 051 R0011	70840 1	P6	0.06	1
	Test Aerosol for Smoke Detector Testing	FPA03	GH V902 0012 V0021	53444 4	P6	0.3	1

Order Number 2CDC 542 040 D0201 printed in Germany (11/10-3-ZVD)

ABB STOTZ-KONTAKT GmbH

Eppelheimer Straße 82
69123 Heidelberg, Germany
Phone: +49 (0)6221 701 607
Fax: +49 (0)6221 701 724
E-Mail: knx.marketing@de.abb.com

Further Information and Local Contacts:
www.abb.com/knx

Note:

We reserve the right to make technical changes or modify the contents of this document without prior notice. With regard to purchase orders, the agreed particulars shall prevail.

ABB AG does not accept any responsibility whatsoever for potential errors or possible lack of information in this document.

We reserve all rights in this document and in the subject matter and illustrations contained therein. Any reproduction, disclosure to third parties or utilization of its contents - in whole or in parts - is forbidden without prior written consent of ABB AG.

Copyright© 2010 ABB
All rights reserved