

Security Products

Automatic Fire Detector in Conventional Technology

Detector Base 12/24 V DC - FC600/BREL

Technical Data

- Detector Base for connection of Fire Detectors of the FC600 detector series to Intrusion Alarm Panels, KNX Zone Terminals and other signal processing equipment
- Connection via change-over contact 30 V/1 A
- Supply voltage 12 V DC (default) or 24 V DC
- Simple handling with bayonet connection
- Optional tamper protection



Description

The Detector Base FC600/BREL enables system-independent connection of the FC600 series (see technical data of the fire detector series FC600 – 2CDC 542 040 D0101) fire detector to systems or devices that are not specifically designed for this detector technology. Examples include Intrusion Alarm Panels, KNX Zone Terminals, elevator controls or other signal processing equipment. The Detector Base must be supplied by either a 12 V or a 24 V DC voltage supply. The default setting is 12 V. A 30 V DC/1 A change-over contact is provided for transferring an alarm. If the base is connected to a standard conventional Fire Alarm Panel (see detector data sheet), in addition to alerting via the panel, any number of control tasks can be executed via a change-over contact.

Application

The Detector Base is intended for fixed installation of a detector in dry rooms. Its location and the required number per room can be determined with the standards and regulations that apply for the design of fire detection systems. It is necessary to consider whether the detectors are required in private areas or areas open to the public. If a Detector Base is installed, the detector can be simply inserted into the base and turned-in in a clockwise direction.

Function

Should a detector installed in the Detector Base go on alarm, the alarm state is indicated by an LED on the detector head, and the change-over contact also switches. The Detector and Detector Base remain in the alarm state, until the supply voltage is switched off.

Resetting the detector in the triggered alarm state

A detector that is signalling an alarm is reset by switching off its supply voltage. This can be implemented, for example, so that a relay in the Intrusion Alarm Panel is programmed to switch during a reset of the Intrusion Alarm Panel. If the power supply to the detector is routed through the N/C contact of this relay, the detector is automatically reset when the Intrusion Alarm Panel is reset.

Another method is to route the supply over the N/C contact of a pushbutton and to reset the detector on alarm by pressing this button.

Setting the supply voltage

A hole underneath the CE mark is located on the rear of the Detector Base in the square shaped cover for the relay PCB. If a screwdriver is inserted into the hole as shown in the diagram below, the neighbouring PCB track is broken out and the Detector Base is set to a 24 V DC operating voltage supply.

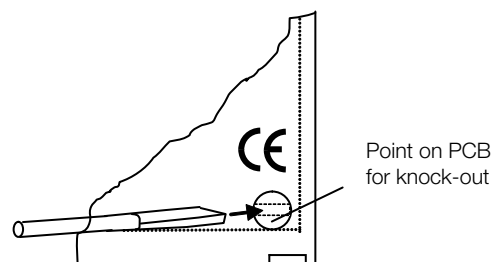

Function test

A function test is performed by triggering the corresponding fire detector with smoke or a test aerosol, by using a blow-drier (heat gun) on the heat detectors or a permanent magnet on all detector types.

Tamper protection

All bases of the FC600 series feature the option of preventing the removal of the detector without the appropriate equipment (see technical data of the “Detector Series FC600”).

Electrical connection - Wiring example with 1 detector in a circuit of an Intrusion Alarm Panel or a KNX Zone Terminal

Variant 1: Without monitoring of the supply voltage and detector removal

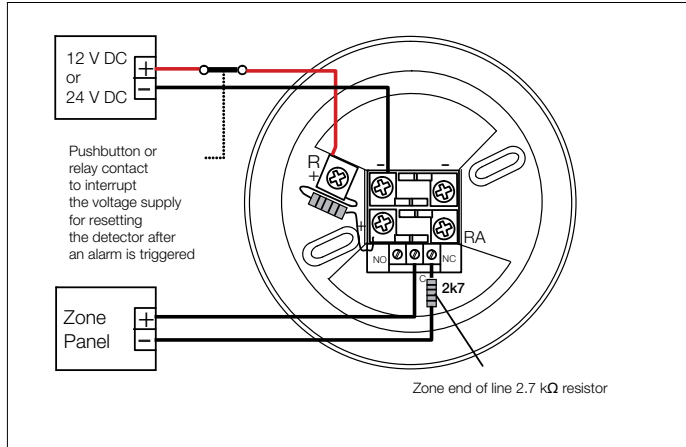

Variant 2: With monitoring of the supply voltage and detector removal

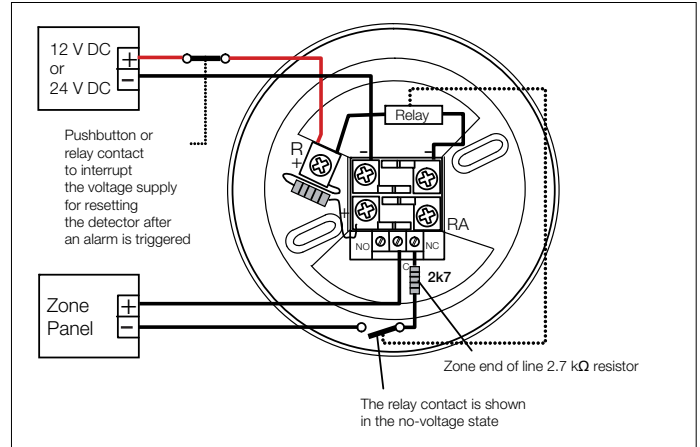

Please note:

- At a voltage supply of 24 V DC, a tab on the circuit board of the relay PCB must be broken out! (see chapter “Setting the supply voltage”).
- The supply voltage must be switched off to reset a triggered detector!
- The contacts “C” and “NC” can be used instead of the contacts “C” and “NO” as a wiring variant. The zone end of line resistor then must not be connected in series to the NC, but rather in parallel to both contacts.

Electrical connection - Wiring example with 3 detectors in a circuit of an Intrusion Alarm Panel or a KNX Zone Terminal

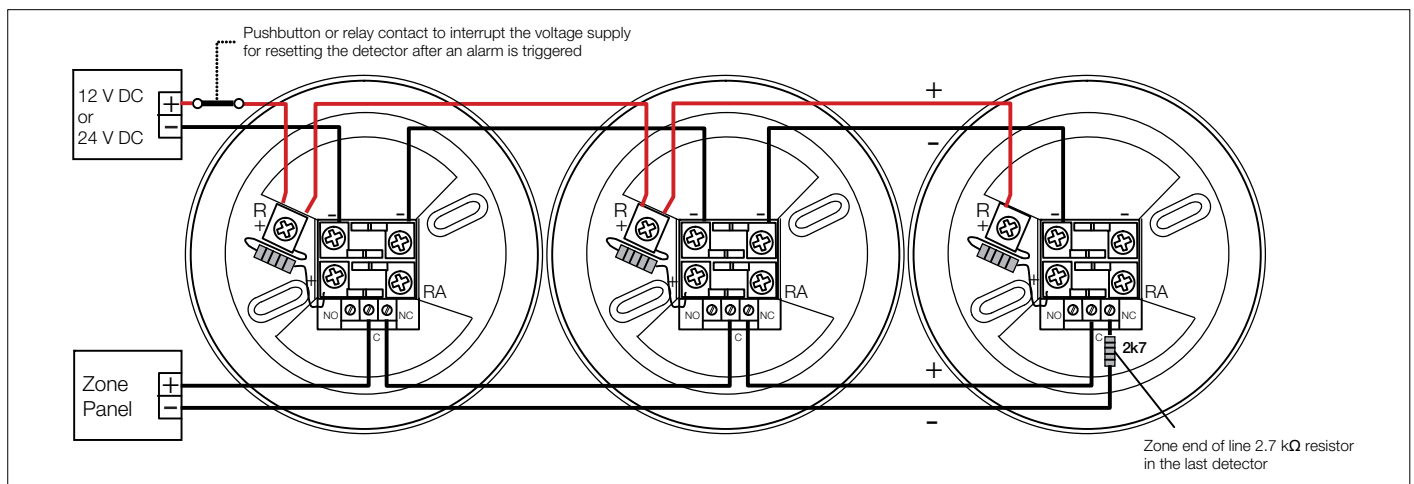

Please note:

- At a voltage supply of 24 V DC, a tab on the circuit board of the relay PCB must be broken out! (refer to separate chapter)
- The supply voltage must be switched off to reset a triggered detector!
- In order to trigger an alarm, should a detector be removed or the supply voltage have failed, it is necessary to install a relay coil on the last detector and configure its N/C contact as indicated in the circuit diagram of a detector “With monitoring of the supply voltage and detector removal”.
- The contacts “C” and “NC” in the **last** detector can also be used instead of the contacts “C” and “NO” as a wiring variant. The zone end of line resistor then must not be connected in series to the NC, but rather in parallel to both contacts.
- If the cable shield (sheath wire) of incoming and outgoing cables is to be looped through, this must be implemented in the base, e.g. using a ferrule or similar device.

Connection to the Intrusion Alarm Panels and KNX Zone Terminal

Panel	Terminal pairs / Zones	Terminal(s) 12 V+	Terminal(s) 12 V-
L108	6-C (fire gas group)	V+	V-
L240	1-C, ..., 6-C	V+	V-
L840/MG4	3-4, 5-6, 7-8, 9-10	1	2
L840/MG2	Please observe the L240 manual		
MT/S 4.12.1	1-2, 3-4, 5-6, 7-8	12	11
MT/U 2.12.1	1-2, 3-4	7	8

Dimension drawing

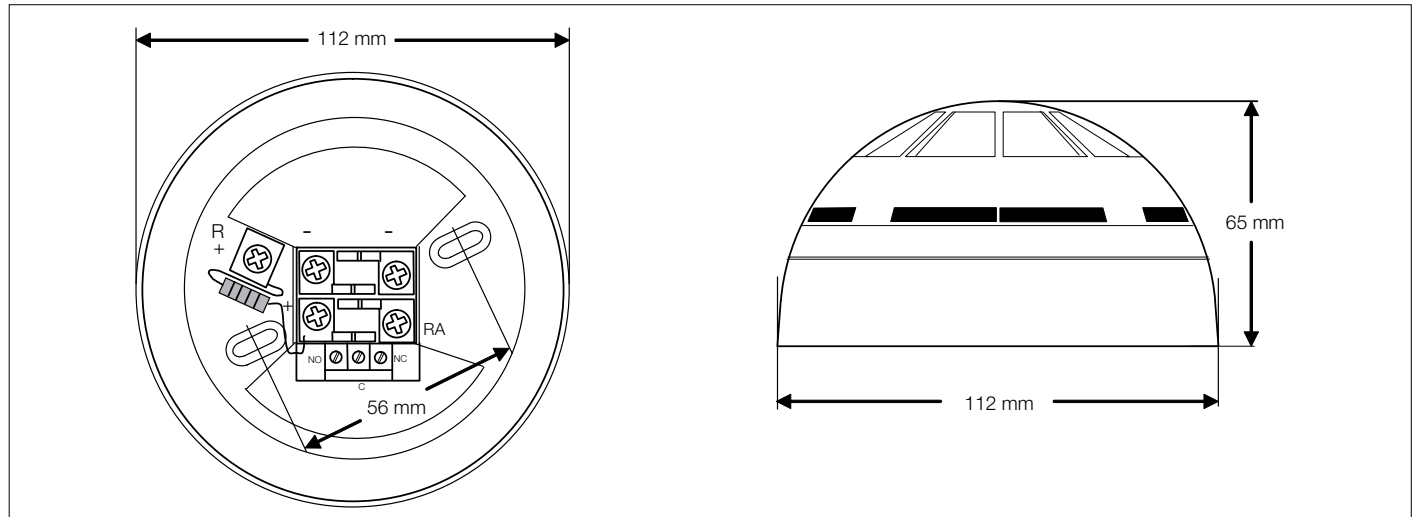

Technical data

Electrical characteristics

Operating voltage	10 to 30 V DC
Current at 12 V DC without detector	
not triggered	max. 1.5 μ A
in alarm	max. 14 mA
Current at 24 V DC without detector	
not triggered	max. 3 μ A
in alarm	max. 17 mA
Relay contact load capacity	30 V / 1 A

General data

Ambient temperature range	- 30 °C to + 70 °C
Relative air humidity	10 to 95 %
Height	27 mm
Diameter	112 mm
Weight	58 g
Admissible conductor cross-section	
Detector contacts	2.5 mm ²
Relay contacts	1.5 mm ²

Ordering details for Detector Base and accessory components

Product photo	Description	Short description	Order code	bbn 40 16779 EAN	Price group	Weight 1 pcs kg	Pack unit pcs.
	Detector Base	FC600/BREL	2CDG 430 051 R0011	70840 1	P6	0.06	1
	Optical Smoke Detector VdS No. G 209200	FC600/O	2CDG 430 047 R0011	70836 4	P6	0.07	1
	Rate-of-Rise Detector VdS No. G 209199	FC600/TDIFF	2CDG 430 048 R0011	70837 1	P6	0.07	1
	Static Heat Detector VdS No. G 209198	FC600/TMAX	2CDG 430 049 R0011	70838 8	P6	0.07	1
	Universal Detector Base	FC600/BR	2CDG 430 050 R0011	70839 5	P6	0.04	1
	Test aerosol for smoke detector testing	FPA03	GH V902 0012 V0021	53444 4	P6	0.3	1

Contact

www.abb.com/knx

Note:

We reserve the right to make technical changes or modify the contents of this document without prior notice. With regard to purchase orders, the agreed particulars shall prevail.

ABB AG does not accept any responsibility whatsoever for potential errors or possible lack of information in this document.

We reserve all rights in this document and in the subject matter and illustrations contained therein. Any reproduction, disclosure to third parties or utilization of its contents - in whole or in parts - is forbidden without prior written consent of ABB AG.

Copyright© 2010 ABB
All rights reserved

Order Number 2CDC 542 041 D0201 printed in Germany (05/10-1-ZVD)