

ABB i-bus[®] KNX Switch Actuators SA/S Product Manual

Contents	Page
1 General	3
1.1 Using the product manual	3
1.1.1 Structure of the product manual.....	4
1.1.2 Note	4
1.2 Product and functional overview.....	5
2 Device technology	7
2.1 6 A Switch Actuator SA/S x.6.1.1, MDRC	7
2.1.1 Technical data.....	7
2.1.2 Output lamp load at 230 V AC	9
2.1.3 Connection schematic SA/S x.6.1.1	10
2.1.4 Dimension drawing SA/S x.6.1.1.....	11
2.2 10 A Switch Actuator SA/S x.10.2.1, MDRC	12
2.2.1 Technical data.....	12
2.2.2 Output lamp load 10 A.....	14
2.2.3 Connection schematic SA/S x.10.2.1	15
2.2.4 Dimension drawing SA/S x.10.2.1.....	16
2.3 16 A Switch Actuator SA/S x.16.2.1, MDRC	17
2.3.1 Technical data.....	17
2.3.2 Output lamp load 16 A.....	19
2.3.3 Connection schematic SA/S x.16.2.1	20
2.3.4 Dimension drawing SA/S x.16.2.1.....	21
2.4 16/20 A Switch Actuators SA/S x.16.5.1, MDRC.....	22
2.4.1 Technical data.....	22
2.4.2 Output lamp load 16/20 A	24
2.4.3 Connection schematic SA/S 12.16.5.1	25
2.4.4 Dimension drawing SA/S 12.16.5.1.....	26
2.5 16/20 A Switch Actuators SA/S x.16.6.1, MDRC.....	27
2.5.1 Technical data.....	27
2.5.2 Output lamp load 16/20 A	29
2.5.3 Connection schematic SA/S x.16.6.1	32
2.5.4 Dimension drawing SA/S x.16.6.1.....	33
2.6 Switching capacities overview.....	34
2.7 Ballast calculation.....	35
2.8 AC1, AC3, AX, C-Load specifications.....	36
2.9 Current detection specifications	37
2.10 Assembly and installation.....	40
3 Commissioning	43
3.1 Overview	44
3.1.1 Conversion of previous application program versions.....	47
3.1.1.1 Conversion options	47
3.1.1.1.1 Conversion summary.....	49
3.1.1.2 Procedure.....	50
3.1.2 Copying and exchanging parameter settings	51
3.1.2.1 Procedure.....	52
3.1.2.2 Dialog Copy/exchange channel.....	53
3.2 Parameters.....	55
3.2.1 Parameter window <i>General</i>	56
3.2.2 Parameter window <i>A: General</i>	60

3.2.3	Operating mode <i>Switch Actuator</i>	61
3.2.3.1	Parameter window A: <i>Function</i>	65
3.2.3.1.1	Parameter window A: <i>Time</i>	70
3.2.3.1.2	Parameter window A: <i>Preset</i>	80
3.2.3.1.3	Parameter window A: <i>Scene</i>	83
3.2.3.1.4	Parameter window A: <i>Logic</i>	85
3.2.3.1.5	Parameter window A: <i>Safety</i>	88
3.2.3.1.6	Parameter window A: <i>Threshold value</i>	92
3.2.3.1.7	Parameter window A: <i>Current Detection</i>	95
3.2.4	Communication objects mode <i>Switch Actuator</i>	103
3.2.4.1	Communication objects <i>General</i>	103
3.2.4.2	Communication objects <i>Output A</i>	105
3.2.5	Operating mode <i>Heating Actuator</i>	149
3.2.5.1	Parameter window A: <i>Function</i>	154
3.2.5.1.1	Parameter window A: <i>Monitoring</i>	157
3.2.5.1.2	Parameter window A: <i>Forced Operation</i>	159
3.2.5.1.3	Parameter window A: <i>Valve Purge</i>	160
3.2.5.1.4	Parameter window A: <i>Current Detection</i>	162
3.2.6	Communications objects Mode <i>Heating Actuator</i>	163
3.2.6.1	Communication objects <i>General</i>	163
3.2.6.2	Communication objects <i>Output A</i>	165
4	Planning and application	171
4.1	Current detection	171
4.1.1	Function threshold with current detection.....	172
4.1.2	Display operating states	173
4.1.3	Recoding of operating hours.....	174
4.1.4	Trend analysis.....	175
4.1.5	Current display	176
4.2	Operating mode <i>Switch Actuator</i>	177
4.2.1	Function chart	177
4.2.2	Function Time	178
4.2.2.1	Staircase light.....	178
4.2.2.2	Switching ON and OFF delay	181
4.2.2.3	Flashing.....	182
4.2.3	Function Connection/Logic	183
4.2.4	Function preset.....	185
4.2.5	Function Scene	187
4.2.6	Function Threshold.....	190
4.3	Operating mode <i>Heating Actuator</i>	192
4.3.1	Function chart	192
4.3.2	2 step control.....	193
4.3.3	Pulse width modulation (PWM).....	194
4.3.4	Pulse width modulation – calculation	195
4.3.5	Lifetime examination of a PWM control	196
4.4	Behaviour with bus voltage failure, recovery and download	197
A	Appendix	201
A.1	Scope of delivery	201
A.2	Code table scene (8 bit).....	201
A.3	Ordering information	203
A.4	Notes.....	205
A.5	Notes.....	206

1 General

The KNX systems offer an attractive solution which, fulfils the highest standards in residential, commercial and public buildings. Quality of living, comfort and safety can be easily combined with cost-effectiveness and environmental awareness using the KNX bus systems from ABB. The KNX products cover the entire range of applications in buildings: from illumination and blind control to heating, ventilation, energy management, security and surveillance. These demands can be realised cost-effectively with minimal planning and installation effort using the ABB KNX. Furthermore, the flexible usage of rooms and the continuous adaptation to changing requirements are simple to realise. The Switch Actuators SA/S fulfil individual demands in functional buildings as well as in the private sector when controlling and switching loads, e.g.:

- Lighting
- Heating control
- Signalling equipment

Furthermore, certain load current types can be detected and monitored using the function threshold value. Reactions on the KNX can be triggered depending on the load current, and the load can be switched off directly or switched via KNX.

1.1 Using the product manual

This manual provides you with detailed technical information relating to the ABB i-bus[®] Switch Actuator range SA/S, its installation and programming. The application of the device is described using examples.

This manual is divided into the following sections:

Chapter 1	General
Chapter 2	Device technology
Chapter 3	Commissioning
Chapter 4	Planning and application
Chapter A	Appendix

1.1.1 Structure of the product manual

All parameters are described in chapter 3.

Note

In this product manual, all the current 2/4/8 and 12-fold Switch Actuators are described. However, as the functions for all outputs are identical, only the functions of output A will be described.

Should the details in the product manual refer to all outputs, 2-fold corresponds to outputs A...B, 4-fold corresponds to outputs A...D, 8-fold corresponds to outputs A...H and 12-fold corresponds to outputs A...L, the designation outputs A...X is used.

The variants with current detection feature an additional parameter page as well as additional communication objects for this function.

1.1.2 Note

Notes and safety instructions are represented as follows in this product manual:

Note

Tips for usage and operation

Examples

Application examples, installation examples, programming examples

Important

These safety instructions are used as soon as there is danger of a malfunction without risk of damage or injury.

Caution

These safety instructions are used if there is a danger of damage with inappropriate use.

Danger

These safety instructions are used if there is a danger for life and limb with inappropriate use.

Danger

These safety instructions are used if there is a danger to life with inappropriate use.

1.2 Product and functional overview

Examples:

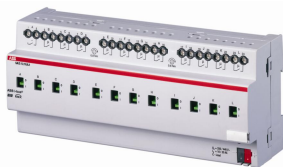

SA/S 12.16.6.1



SA/S 8.16.6.1



SA/S 4.16.2.1



SA/S 2.10.2.1



SA/S 12.6.1.1



SA/S 8.6.1.1



SA/S 4.6.1.1

The ABB i-bus® KNX Switch Actuators SA/S are modular installation devices with module widths of 2/4/8/12 space units in ProM design for installation in a distribution board. The connection to the ABB i-bus® is established using the front side bus connection terminal. The Switch Actuators do not require auxiliary voltage. The assignment of the physical addresses as well as the parameterization is carried out with Engineering Tool Software ETS from Version ETS2 V1.3a. If ETS3 or ETS4 is used, the corresponding application program must be imported.

Note

The illustrations of the parameter windows in this manual correspond to the ETS3 parameter windows. The user program is optimised for ETS3.

In the ETS2, it is possible that the parameter page is automatically split if all parameters are used.

The Switch Actuators can switch 2 to 12 independent electrical AC or three-phase loads via KNX with floating contacts. For types SA/S x.16.6.1 it is possible to detect the load current for each output. The outputs of the 10A, 16 A and 16/20 A Switch Actuators can be switched on and off manually. The switching states are displayed.

For switching loads with high peak inrush currents, e.g. lighting equipment with compensation capacitors or fluorescent lamp loads (AX) to EN 60669, the Switch Actuators SA/S x.16.6.1 and SA/S 12.16.5.1 with the highest switching capacity (C-Load) are especially suitable.

The following functions can be set individually for each output:

- Functions time, on and off delay
- Function *Warning staircase lighting* and modifiable staircase lighting time
- Recall of scenes/presets via 8/1 bit commands
- Logical functions AND, OR, XOR, GATE function
- Status messages
- Functions forced operation and safety
- Reaction to threshold values
- Control of electro-thermal valve drives
- Selection of the preferred position at bus voltage failure and bus voltage recovery
- Inverting of the outputs

Furthermore, the Switch Actuators with current detection, SA/S x.16.6.1, feature per output the function load current detection with programmable reaction to two current threshold values. The current value can be sent via the bus. Individual outputs can be copied or exchanged to reduce the programming effort to the minimum in the Switch Actuators SA/S x.16.6.1 and SA/S x.16.5.1.

Switch Actuators SA/S x.16.6.1 feature a current accuracy that is factor 4 higher than the predecessor SA/S x.16.5.S. The SA/S x.16.6.1 and SA/S x.16.5.1 are suitable for rated currents up to 20 A and feature C-Load switching capacity.

In the following table, you will find an overview of the ABB i-bus® Switch Actuators and their type designations:

–	SA/S 2.10.2.1	SA/S 2.16.2.1	SA/S 2.16.5.1	SA/S 2.16.6.1
SA/S 4.6.1.1	SA/S 4.10.2.1	SA/S 4.16.2.1	SA/S 4.16.5.1	SA/S 4.16.6.1
SA/S 8.6.1.1	SA/S 8.10.2.1	SA/S 8.16.2.1	SA/S 8.16.5.1	SA/S 8.16.6.1
SA/S 12.6.1.1	SA/S 12.10.2.1	SA/S 12.16.2.1	SA/S 12.16.5.1	SA/S 12.16.6.1

Note

The codes represent the following:

SA/S x.y.z.w

x = number of outputs (2, 4, 8 or 12)

y = rated current in Amperes (6, 10, 16 and 16/20 A)

z = load type specification:

1 = type without manual operation

2 = type with manual operation

5 = type with higher switch capacity C-Load (200 µF)

6 = type with higher switch capacity C-Load and current detection

w = version number

2 Device technology

2.1 6 A Switch Actuator SA/S x.6.1.1, MDRC



SA/S 12.6.1.1

2CDC 071033S0012

The 6 A Switch Actuators SA/S x.6.1.1 are modular installation devices in ProM design for installation in the distribution board. The devices are suitable for switching resistive, inductive and capacitive loads. The Switch Actuators can switch up to 12 independent electrical loads via floating contacts. For SA/S 8.6.1.1 and SA/S 12.6.1.1 the outputs are connected using screw terminals in groups of 2 contacts. SA/S 4.6.1.1 has for every contact a separate load terminal. Independent of the output number each output is controlled separately via the KNX.

The device does not require an additional power supply and is ready for immediate use, after the bus voltage has been applied. The Switch Actuator is parameterised via ETS. The connection to the KNX is implemented using the bus connection terminal on the front.

2.1.1 Technical data

Supply	KNX-Bus voltage	21...31 V DC		
	Current consumption, bus	< 12 mA		
	Power consumption	Maximum 250 mW		
Output rated value	SA/S type	4.6.1.1	8.6.1.1	12.6.1.1
	Current detection	no	no	no
	Number (floating contacts 2/group)	4*)	8	12
	U _n rated voltage	250/440 V AC (50/60 Hz)		
	I _n rated current (per output)	6 A	6 A	6 A
	Leakage loss per device at max. load	1.5 W	2.0 W	2.5 W
	Output switching current	AC3 ¹⁾ operation (cos φ = 0.45) to EN 60 947-4-1	6 A/230 V AC	
AC1 ¹⁾ operation (cos φ = 0.8) to EN 60 947-4-1		6 A/230 V AC		
Fluorescent lighting load to EN 60 669-1		6 A/250 V AC (35 μF) ²⁾		
Minimum switching performance		20 mA/5 V AC 10 mA/12 V AC 7 mA/24 V AC		
Output service life	Mechanical service life	> 10 ⁷		
	Electrical endurance to IEC 60 947-4-1			
	AC1 ¹⁾ (240 V/cos φ = 0.8)	> 10 ⁵		
	AC3 ¹⁾ (240 V/cos φ = 0.45)	> 1.5 x 10 ⁴		
	AC5a ¹⁾ (240 V/cos φ = 0.45)	> 1.5 x 10 ⁴		
*) Each output has his own load terminal.				

Output switching times³⁾	Maximum relay position change of output and minute if all relays are switched simultaneously. The position changes should be distributed equally within the minute.	4.6.1.1 60	8.6.1.1 30	12.6.1.1 20
	Maximum relay position change per output and minute if only one relay is switched.	240	240	240
Connections	KNX	Via bus connection terminals 0.8 mm Ø, solid		
	Load current circuits (1 terminal per contact)	Screw terminal		
	Phase (1 terminal for 2 contacts)	0.2... 2.5 mm ² stranded 0.2... 4 mm ² solid		
	Tightening torque	Maximum 0.6 Nm		
Operating and display elements	Programming button/LED	For assignment of the physical address		
Enclosure	IP 20	To DIN EN 60 529		
Safety class	II	To DIN EN 61 140		
Isolation category	Overvoltage category	III to EN 60 664-1		
	Pollution degree	2 to EN 60 664-1		
KNX safety extra low voltage	SELV 24 V DC			
Temperature range	Operation	-5 °C...+45 °C		
	Storage	-25 °C...+55 °C		
	Transport	-25 °C...+70 °C		
Ambient conditions	Maximum air humidity	95 %, no condensation allowed		
Design	Modular installation device (MDRC)	Modular installation device, ProM		
	SA/S type	4.6.1.1	8.6.1.1	12.6.1.1
	Dimensions	90 x W x 64.5 mm (H x W x D)		
	Width W in mm	72	108	144
	Mounting width in space units (modules at 18 mm)	4	6	8
	Mounting depth in mm	64,5	64.5	64.5
Weight	in kg	0.13	0.24	0.3
Installation	On 35 mm mounting rail	To EN 60 715		
Mounting position	As required			
Housing/colour	Plastic housing, grey			
Approvals	KNX to EN 50 090-1, -2	Certification		
CE mark	In accordance with the EMC guideline and low voltage guideline			

¹⁾ Further information concerning electrical endurance to IEC 60 947-4-1 can be found at: [AC1-, AC3-, AX-, C-Load specifications](#), page 36.

²⁾ The maximum peak inrush current may not be exceeded.

³⁾ The specifications apply only after the bus voltage has been applied to the device for at least 30 seconds. Typical response delay of the relay is approx. 20 ms.

2.1.2 Output lamp load at 230 V AC

Lamps	Incandescent lamp load	1200 W
Fluorescent lamps T5 / T8	Uncorrected	800 W
	Parallel compensated	300 W
	DUO circuit	350 W
Low-voltage halogen lamps	Inductive transformer	800 W
	Electronic transformer	1000 W
	Halogen lamps 230 V	1000 W
Dulux lamp	Uncorrected	800 W
	Parallel compensated	800 W
Mercury-vapour lamp	Uncorrected	1000 W
	Parallel compensated	800 W
Switching performance (switching contact)	Maximum peak inrush-current I_p (150 μ s)	200 A
	Maximum peak inrush-current I_p (250 μ s)	160 A
	Maximum peak inrush-current I_p (600 μ s)	100 A
Number of electronic ballasts (T5/T8, single element)¹⁾	18 W (ABB EVG 1 x 18 SF)	10
	24 W (ABB EVG-T5 1 x 24 CY)	10
	36 W (ABB EVG 1 x 36 CF)	7
	58 W (ABB EVG 1 x 58 CF)	5
	80 W (Helvar EL 1 x 80 SC)	3

¹⁾ For multiple element lamps or other types, the number of electronic ballasts must be determined using the peak inrush current of the electronic ballasts, see [Ballast calculation](#), page 35.

Device type	Application program	Maximum number of communication objects	Maximum number of group addresses	Maximum number of associations
SA/S 4.6.1.1	Switch 4f 6A/...*	64	254	254
SA/S 8.6.1.1	Switch 8f 6A/...*	124	254	254
SA/S 12.6.1.1	Switch 12f 6A/...*	184	254	254

* ... = current version number of the application program

Note

The ETS and the current version of the device application program are required for programming.

The current version of the application program is available for download on the Internet at www.abb.com/knx. After import it is available in the ETS under *ABB/Output/Binary output xf 6A/...** ($x = 4, 8$ or 12).

The device does not support the closing function of a KNX device in the ETS. If you inhibit access to all devices of the project with a BCU code, it has no effect on this device. Data can still be read and programmed.

2.1.3 Connection schematic
SA/S x.6.1.1

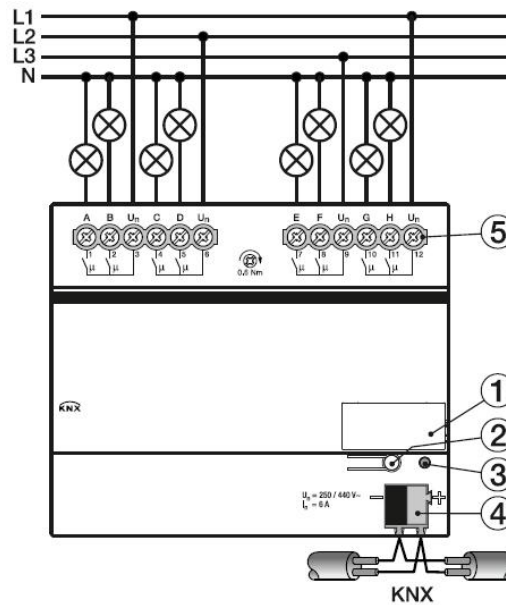

2CDC 072 471 Fxxx

- 1 Label carrier
- 2 Button *Programming*
- 3 LED *Programming*
- 4 Bus connection terminal
- 5 Load current circuit, 1 screw terminal for phase connection per contact

 **Danger**

Touch voltages.
Danger of injury.
Note the all-pole disconnection.

2.1.4 Dimension drawing
SA/S x.6.1.1

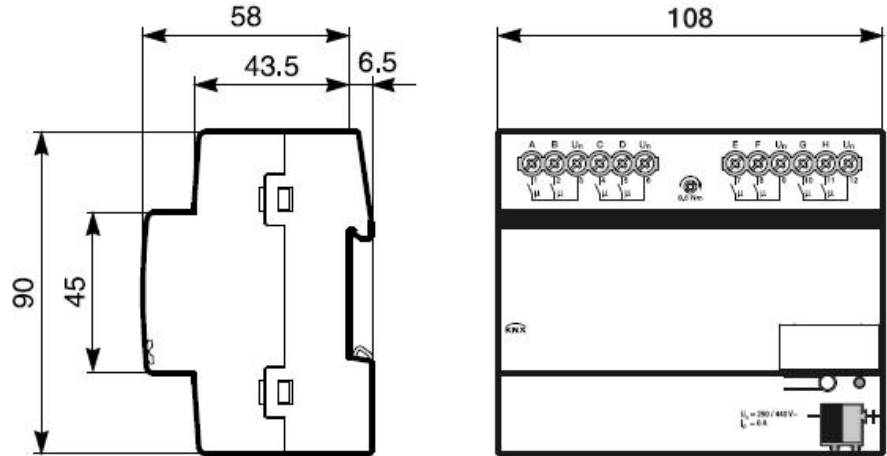

2CDC 072 192 Fxxx

	SA/S 4.6.1.1	SA/S 8.6.1.1	SA/S 12.6.1.1
Width W	72 mm	108 mm	144 mm
Mounting width (modules at 18 mm)	4 space units	6 space units	8 space units

2.2 10 A Switch Actuator
SA/S x.10.2.1, MDRC

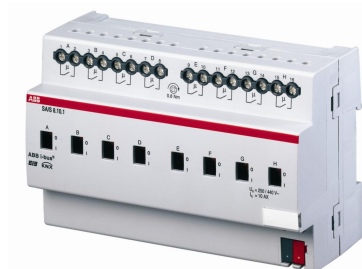

2CDC 071 013 F0005

SA/S 8.10.2.1

The 10 A Switch Actuators SA/S x.10.2.1 are modular installation devices in ProM design for installation in the distribution board. The devices are suitable for switching resistive, inductive and capacitive loads as well as fluorescent lamp loads (AX) to EN 60 669.

Manual actuation of the Switch Actuator is possible using a button. This simultaneously indicates the switching state.

The Switch Actuators can switch up to 12 independent electrical loads via floating contacts. The connection of the outputs is implemented using universal head screw terminals. Each output is controlled separately via the KNX.

The device does not require an additional power supply and is ready for immediate use, after the bus voltage has been applied.

The Switch Actuator is parameterised via ETS. The connection to the KNX is implemented using the bus connection terminal on the front.

2.2.1 Technical data

Supply	KNX-Bus voltage	21...31 V DC			
	Current consumption via bus	< 12 mA			
	Power consumption via bus	Maximum 250 mW			
Output rated value	SA/S type	2.10.2.1	4.10.2.1	8.10.2.1	12.10.2.1
	Current detection	no	no	no	no
	Number (floating contacts 2/group)	2	4	8	12
	U _n rated voltage	250/440 V AC (50/60 Hz)			
	I _n rated current	10 AX	10 AX	10 AX	10 AX
	Leakage loss per device at max. load	1.5 W	2.0 W	2.5 W	6.5 W
Output switching current	AC3 ¹⁾ operation (cos φ = 0.45) to EN 60 947-4-1	8 A/230 V AC			
	AC1 ¹⁾ operation (cos φ = 0.8) to EN 60 947-4-1	10 A/230 V AC			
	Fluorescent lighting load to EN 60 669-1	10 AX/250 V AC (140 μF) ²⁾			
	Minimum switching performance	100 mA/12 V AC			
		100 mA/24 V AC			
7 mA/24 V AC					
DC current switching capacity (resistive load)	10 A/24 V DC				
Output service life	Mechanical service life	> 3 x 10 ⁶			
	Electrical endurance to IEC 60 947-4-1	AC1 ¹⁾ (240 V/cos φ = 0.8)			
		> 10 ⁵			
	AC3 ¹⁾ (240 V/cos φ = 0.45)	> 3 x 10 ⁴			
	AC5a ¹⁾ (240 V/cos φ = 0.45)	> 3 x 10 ⁴			

Output switching times³⁾	Maximum relay position change of output and minute if all relays are switched simultaneously. The position changes should be distributed equally within the minute.	2.10.2.1 60	4.10.2.1 30	8.10.2.1 15	12.10.2.1 10
	Maximum relay position change per output and minute if only one relay is switched.	120	120	120	120
Connections	KNX	Via bus connection terminals 0.8 mm Ø, solid			
	Load current circuits (1 terminal per contact)	Universal head screw terminal (PZ 1) 0.2...4 mm ² stranded, 2 x 0.2...2.5 mm ² 0.2...6 mm ² solid, 2 x 0.2...4 mm ²			
	Ferrules without/with plastic sleeves	0.25...2.5/4 mm ²			
	TWIN ferrules	0.5...2.5 mm ² Contact pin length at least 10 mm			
	Tightening torque	Maximum 0.6 Nm			
Operating and display elements	Programming button/LED	For assignment of the physical address			
	Switch position display	Relay operator			
Enclosure	IP 20	To EN 60 529			
Safety class	II	To EN 61 140			
Isolation category	Overvoltage category	III to EN 60 664-1			
	Pollution degree	2 to EN 60 664-1			
KNX safety extra low voltage	SELV 24 V DC				
Temperature range	Operation	-5 °C...+45 °C			
	Storage	-25 °C...+55 °C			
	Transport	-25 °C...+70 °C			
Ambient conditions	Maximum air humidity	95 %, no condensation allowed			
Design	Modular installation device (MDRC)	Modular installation device, ProM			
	SA/S type	2.10.2.1	4.10.2.1	8.10.2.1	12.10.2.1
	Dimensions	90 x W x 64.5 mm (H x W x D)			
	Width W in mm	36	72	144	216
	Mounting width in space units (modules at 18 mm)	2	4	8	12
	Mounting depth in mm	64.5	64.5	64.5	64.5
Weight	in kg	0.15	0.25	0.46	0.65
Installation	On 35 mm mounting rail	To EN 60 715			
Mounting position	As required				
Housing/colour	Plastic housing, grey				
Approvals	KNX to EN 50 090-1, -2	Certification			
CE mark	In accordance with the EMC guideline and low voltage guideline				

¹⁾ Further information concerning electrical endurance to IEC 60 947-4-1 can be found at: [AC1-, AC3-, AX-, C-Load specifications](#), page 36.

²⁾ The maximum peak inrush current may not be exceeded.

³⁾ The specifications apply only after the bus voltage has been applied to the device for at least 30 seconds. Typical response delay of the relay is approx. 20 ms.

2.2.2 Output lamp load 10 A

Lamps	Incandescent lamp load	2500 W
Fluorescent lamps T5 / T8	Uncorrected	2500 W
	Parallel compensated	1500 W
	DUO circuit	1500 W
Low-voltage halogen lamps	Inductive transformer	1200 W
	Electronic transformer	1500 W
	Halogen lamps 230 V	2500 W
Dulux lamp	Uncorrected	1100 W
	Parallel compensated	1100 W
Mercury-vapour lamp	Uncorrected	2000 W
	Parallel compensated	2000 W
Switching performance (switching contact)	Maximum peak inrush-current I_p (150 μ s)	400 A
	Maximum peak inrush-current I_p (250 μ s)	320 A
	Maximum peak inrush-current I_p (600 μ s)	200 A
Number of electronic ballasts (T5/T8, single element)¹⁾	18 W (ABB EVG 1 x 18 SF)	23
	24 W (ABB EVG-T5 1 x 24 CY)	23
	36 W (ABB EVG 1 x 36 CF)	14
	58 W (ABB EVG 1 x 58 CF)	11
	80 W (Helvar EL 1 x 80 SC)	10

¹⁾ For multiple element lamps or other types, the number of electronic ballasts must be determined using the peak inrush current of the electronic ballasts, see [Ballast calculation](#), page 35.

Device type	Application program	Maximum number of communication objects	Maximum number of group addresses	Maximum number of associations
SA/S 2.10.2.1	Switch 2f 10A/...*	34	254	254
SA/S 4.10.2.1	Switch 4f 10A/...*	64	254	254
SA/S 8.10.2.1	Switch 8f 10A/...*	124	254	254
SA/S 12.10.2.1	Switch 12f 10A/...*	184	254	254

* ... = current version number of the application program

Note

The ETS and the current version of the device application program are required for programming.

The current version of the application program is available for download on the Internet at www.abb.com/knx. After import it is available in the ETS under *ABB/Output/Binary output xf 10A/...** ($x = 2, 4, 8$ or 12).

The device does not support the closing function of a KNX device in the ETS. If you inhibit access to all devices of the project with a BCU code, it has no effect on this device. Data can still be read and programmed.

2.2.3 Connection schematic
SA/S x.10.2.1

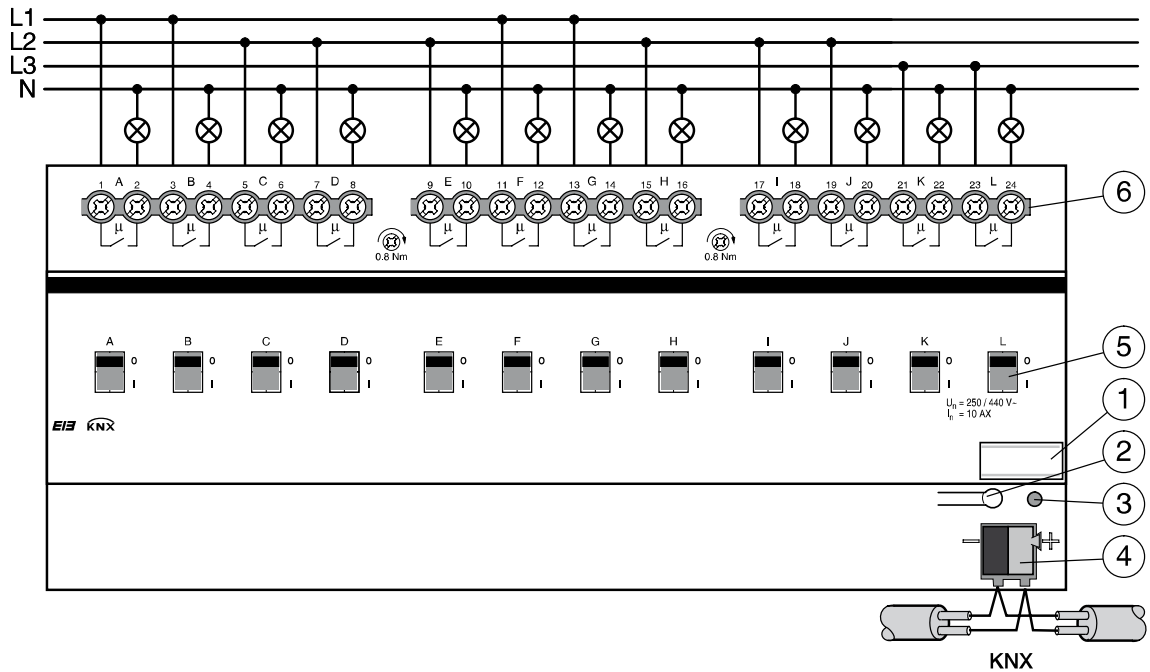

- 1 Label carrier
- 2 Button *Programming*
- 3 LED *Programming*
- 4 Bus connection terminal
- 5 Switch position display and manual operation
- 6 Load circuit, with 2 terminals each

⚠ ⚡ Danger

Touch voltages.
Danger of injury.
Note the all-pole disconnection.

2CDC 072 536 F0004

2.2.4 Dimension drawing
SA/S x.10.2.1

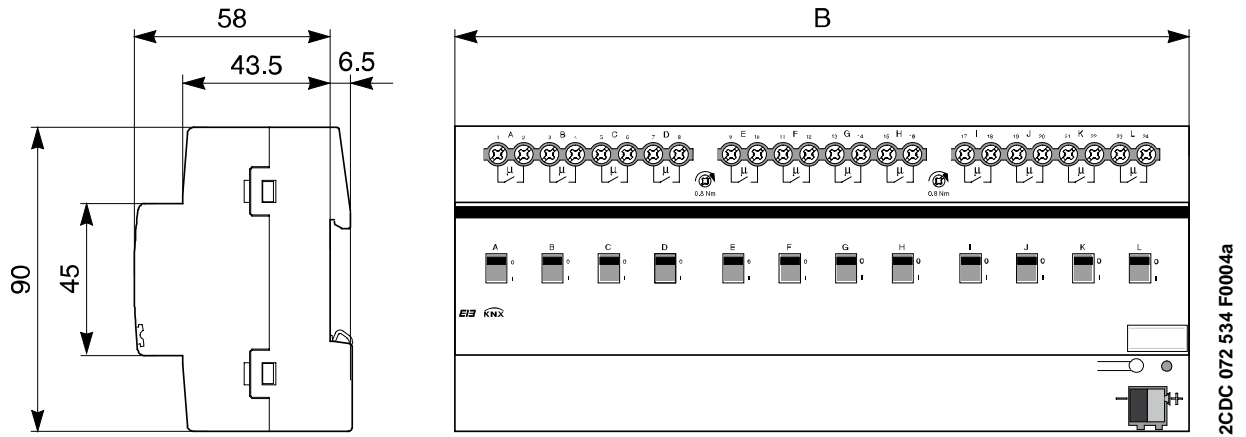

	SA/S 2.10.2.1	SA/S 4.10.2.1	SA/S 8.10.2.1	SA/S 12.10.2.1
Width W	36 mm	72 mm	144 mm	216 mm
Mounting width (modules at 18 mm)	2 space units	4 space units	8 space units	12 space units

2.3 16 A Switch Actuator SA/S x.16.2.1, MDRC



2CDC 071 056 F0005

SA/S 8.16.2.1

The 16 A Switch Actuators SA/S x.16.2.1 are modular installation devices in ProM design for installation in the distribution board. The devices are especially suitable for switching resistive loads.

Manual actuation of the Switch Actuator is possible using a button. This simultaneously indicates the switching state.

The Switch Actuators can switch up to 12 independent electrical loads via floating contacts. The connection of the outputs is implemented using universal head screw terminals. Each output is controlled separately via the KNX.

The device does not require an additional power supply and is ready for immediate use, after the bus voltage has been applied.

The Switch Actuator is parameterised via ETS. The connection to the KNX is implemented using the bus connection terminal on the front.

2.3.1 Technical data

Supply	KNX-Bus voltage	21...31 V DC			
	Current consumption via bus	< 12 mA			
	Power consumption via bus	Maximum 250 mW			
Output rated value	SA/S type	2.16.2.1	4.16.2.1	8.16.2.1	12.16.2.1
	Current detection	no	no	no	no
	Number (floating contacts 2/group)	2	4	8	12
	U _n rated voltage	250/440 V AC (50/60 Hz)			
	I _n rated current	16 A	16 A	16 A	16 A
	Leakage loss per device at max. load	2.0 W	4.0 W	8.0 W	12.0 W
	Output switching current	AC3 ¹⁾ operation (cos φ = 0.45) to EN 60 947-4-1	8 A/230 V AC		
AC1 ¹⁾ operation (cos φ = 0.8) to EN 60 947-4-1		16 A/230 V AC			
Fluorescent lighting load to EN 60 669-1		16 AX/250 V AC (70 μF) ²⁾			
Minimum switching performance		100 mA/12 V AC 100 mA/24 V AC 7 mA/24 V AC			
DC current switching capacity (resistive load)		16 A/24 V DC			
Output service life	Mechanical service life	> 3 x 10 ⁶			
	Electrical endurance to IEC 60 947-4-1				
	AC1 ¹⁾ (240 V/cos φ = 0.8)	> 10 ⁵			
	AC3 ¹⁾ (240 V/cos φ = 0.45)	> 3 x 10 ⁴			
	AC5a ¹⁾ (240 V/cos φ = 0.45)	> 3 x 10 ⁴			

Output switching times³⁾	Maximum relay position change of output and minute if all relays are switched simultaneously. The position changes should be distributed equally within the minute.	2.16.2.1 60	4.16.2.1 30	8.16.2.1 15	12.16.2.1 10
	Maximum relay position change per output and minute if only one relay is switched.	120	120	120	120
Connections	KNX	Via bus connection terminals 0.8 mm Ø, solid			
	Load current circuits (1 terminal per contact)	Universal head screw terminal (PZ 1) 0.2...4 mm ² stranded, 2 x 0.2...2.5 mm ² 0.2...6 mm ² solid, 2 x 0.2...4 mm ²			
	Ferrules without/with plastic sleeves	0.25...2.5/4 mm ²			
	TWIN ferrules	0.5...2.5 mm ² Contact pin length at least 10 mm			
	Tightening torque	Maximum 0.6 Nm			
Operating and display elements	Programming button/LED	For assignment of the physical address			
	Switch position display	Relay operator			
Enclosure	IP 20	To EN 60 529			
Safety class	II	To EN 61 140			
Isolation category	Overvoltage category	III to EN 60 664-1			
	Pollution degree	2 to EN 60 664-1			
KNX safety extra low voltage	SELV 24 V DC				
Temperature range	Operation	-5 °C...+45 °C			
	Storage	-25 °C...+55 °C			
	Transport	-25 °C...+70 °C			
Ambient conditions	Maximum air humidity	95 %, no condensation allowed			
Design	Modular installation device (MDRC)	Modular installation device, ProM			
	SA/S type	2.16.2.1	4.16.2.1	8.16.2.1	12.16.2.1
	Dimensions	90 x W x 64.5 mm (H x W x D)			
	Width W in mm	36	72	144	216
	Mounting width in space units (modules at 18 mm)	2	4	8	12
	Mounting depth in mm	64.5	64.5	64.5	64.5
Weight	in kg	0.15	0.25	0.46	0.65
Installation	On 35 mm mounting rail	To EN 60 715			
Mounting position	As required				
Housing/colour	Plastic housing, grey				
Approvals	KNX to EN 50 090-1, -2	Certification			
CE mark	In accordance with the EMC guideline and low voltage guideline				

¹⁾ Further information concerning electrical endurance to IEC 60 947-4-1 can be found at: [AC1-, AC3-, AX-, C-Load specifications](#), page 36.

²⁾ The maximum peak inrush current may not be exceeded.

³⁾ The specifications apply only after the bus voltage has been applied to the device for at least 30 seconds. Typical response delay of the relay is approx. 20 ms.

2.3.2 Output lamp load 16 A

Lamps	Incandescent lamp load	2500 W
Fluorescent lamps T5 / T8	Uncorrected	2500 W
	Parallel compensated	1500 W
	DUO circuit	1500 W
Low-voltage halogen lamps	Inductive transformer	1200 W
	Electronic transformer	1500 W
	Halogen lamps 230 V	2500 W
Dulux lamp	Uncorrected	1100 W
	Parallel compensated	1100 W
Mercury-vapour lamp	Uncorrected	2000 W
	Parallel compensated	2000 W
Switching performance (switching contact)	Maximum peak inrush-current I_p (150 μ s)	400 A
	Maximum peak inrush-current I_p (250 μ s)	320 A
	Maximum peak inrush-current I_p (600 μ s)	200 A
Number of electronic ballasts (T5/T8, single element)¹⁾	18 W (ABB EVG 1 x 18 SF)	23
	24 W (ABB EVG-T5 1 x 24 CY)	23
	36 W (ABB EVG 1 x 36 CF)	14
	58 W (ABB EVG 1 x 58 CF)	11
	80 W (Helvar EL 1 x 80 SC)	10

¹⁾ For multiple element lamps or other types, the number of electronic ballasts must be determined using the peak inrush current of the electronic ballasts, see [Ballast calculation](#), page 35.

Device type	Application program	Maximum number of communication objects	Maximum number of group addresses	Maximum number of associations
SA/S 2.16.2.1SA/S 2.16.2.1	Switch 2f 16A/...*	34	254	254
SA/S 4.16.2.1	Switch 4f 16A/...*	64	254	254
SA/S 8.16.2.1	Switch 8f 16A/...*	124	254	254
SA/S 12.16.2.1	Switch 12f 16A/...*	184	254	254

* ... = current version number of the application program

Note

The ETS and the current version of the device application program are required for programming.

The current version of the application program is available for download on the Internet at www.abb.com/knx. After import it is available in the ETS under *ABB/Output/Binary output xf 16A/...** ($x = 2, 4, 8$ or 12).

The device does not support the closing function of a KNX device in the ETS. If you inhibit access to all devices of the project with a BCU code, it has no effect on this device. Data can still be read and programmed.

2.3.3 Connection schematic
SA/S x.16.2.1

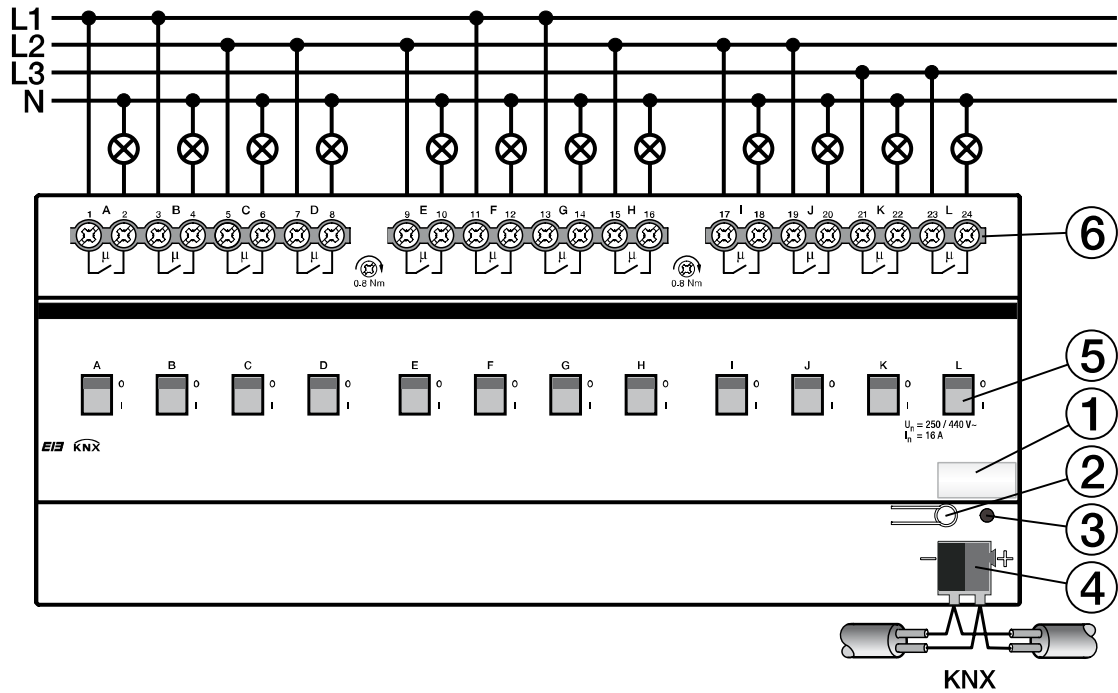

2CDC 072 201 F0006a

- 1 Label carrier
- 2 Button *Programming*
- 3 LED *Programming*
- 4 Bus connection terminal
- 5 Switch position display and manual operation
- 6 Load circuit, with 2 terminals each

⚠ ⚡ Danger

Touch voltages.
Danger of injury.
Note the all-pole disconnection.

2.3.4 Dimension drawing
SA/S x.16.2.1

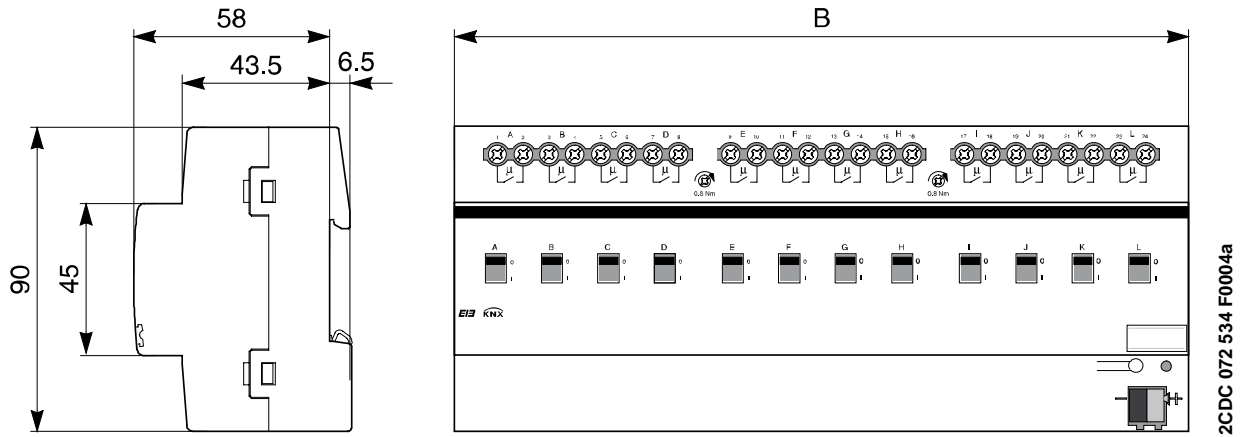

	SA/S 2.16.2.1	SA/S 4.16.2.1	SA/S 8.16.2.1	SA/S 12.16.2.1
Width W	36 mm	72 mm	144 mm	216 mm
Mounting width (modules at 18 mm)	2 space units	4 space units	8 space units	12 space units

2.4 16/20 A Switch Actuators
SA/S x.16.5.1, MDRC

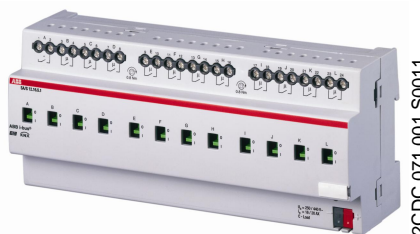

SA/S 12.16.5.1

The 16/20 A Switching actuators SA/S x.16.5.1 are modular installation devices in ProM Design for installation in the distribution board. The devices are particularly suitable for switching loads with high peak inrush currents such as fluorescent lighting with compensation capacitors or fluorescent lamp loads (AX) to EN 60669.

Manual actuation of the Switch Actuator is possible using a button. This simultaneously indicates the switching state.

The Switch Actuators can switch up to 12 independent electrical loads via floating contacts. The maximum load current per output is 20 A. The connection of the outputs is implemented using universal head screw terminals. Each output is controlled separately via the KNX.

The devices do not require an additional power supply and are ready for immediate use, after the bus voltage has been applied.

The Switch Actuators are parameterised via ETS. The connection to the KNX is implemented using the bus connection terminal on the front.

2.4.1 Technical data

Supply	KNX-Bus voltage	21...31 V DC			
	Current consumption via bus	< 12 mA			
	Power consumption via bus	Maximum 250 mW			
Output rated value	SA/S type	2.16.5.1	4.16.5.1	8.16.5.1	12.16.5.1
	Current detection	no	no	no	no
	Number (floating contacts 2/group)	2	4	8	12
	U _n rated voltage	250/440 V AC (50/60 Hz)			
	I _n rated current	16/20 AX, C-Load			
	Leakage loss per device at max. load 16 A	2.0 W	4.0 W	8.0 W	12 W
	Leakage loss per device at max. load 20 A	3.0 W	5.5 W	11.0 W	16 W
Output switching current	AC3 ¹⁾ operation (cos φ = 0.45) to EN 60 947-4-1	16 A/230 V AC			
	AC1 ¹⁾ operation (cos φ = 0.8) to EN 60 947-4-1	16/20 A/230 V AC			
	Fluorescent lighting load to EN 60 669-1	16/20 AX/250 V AC (200 μF) ²⁾			
	Minimum switching performance	100 mA/12 V AC 100 mA/24 V AC 7 mA/24 V AC			
	DC current switching capacity (resistive load)	20 A/24 V DC			
Output service life	Mechanical service life	> 10 ⁶			
	Electrical endurance to IEC 60 947-4-1				
	AC1 ¹⁾ (240 V/cos φ = 0.8)	> 10 ⁵			
	AC3 ¹⁾ (240 V/cos φ = 0.45)	> 3 x 10 ⁴			
	AC5a ¹⁾ (240 V/cos φ = 0.45)	> 3 x 10 ⁴			

Output switching times³⁾	Maximum relay position change of output and minute if all relays are switched simultaneously. The position changes should be distributed equally within the minute.	2.16.5.1 30	4.16.5.1 15	8.16.5.1 7	12.16.5.1 5
	Maximum relay position change per output and minute if only one relay is switched.	60	60	60	60
Connections	KNX	Via bus connection terminals 0.8 mm Ø, solid			
	Load current circuits (2 terminal per relay)	Universal head screw terminal (PZ 1) 0.2...4 mm ² stranded, 2 x 0.2...2.5 mm ² 0.2...6 mm ² solid, 2 x 0.2...4 mm ²			
	Ferrules without/with plastic sleeves	0.25...2.5/4 mm ²			
	TWIN ferrules	0.5...2.5 mm ² Contact pin length at least 10 mm			
	Tightening torque	Maximum 0.6 Nm			
Operating and display elements	Programming button/LED	For assignment of the physical address			
	Switch position display	Relay operator			
Enclosure	IP 20	To EN 60 529			
Safety class	II	To EN 61 140			
Isolation category	Overvoltage category	III to EN 60 664-1			
	Pollution degree	2 to EN 60 664-1			
KNX safety extra low voltage	SELV 24 V DC				
Temperature range	Operation	-5 °C...+45 °C			
	Storage	-25 °C...+55 °C			
	Transport	-25 °C...+70 °C			
Ambient conditions	Maximum air humidity	95 %, no condensation allowed			
Design	Modular installation device (MDRC)	2.16.5.1	4.16.5.1	8.16.5.1	12.16.5.1
	Dimensions	90 x W x 64.5 mm (H x W x D)			
	Width W in mm	36	72	144	216
	Mounting width in space units (modules at 18 mm)	2	4	8	12
	Mounting depth in mm	64.5	64.5	64.5	64.5
Weight	in kg	0.2	0.34	0.64	0.75
Installation	On 35 mm mounting rail	To EN 60 715			
Mounting position	As required				
Housing/colour	Plastic housing, grey				
Approvals	KNX to EN 50 090-1, -2	Certification			
CE mark	In accordance with the EMC guideline and low voltage guideline				

¹⁾ Further information concerning electrical endurance to IEC 60 947-4-1 can be found at: [AC1-, AC3-, AX-, C-Load specifications](#), page 36.

²⁾ The maximum peak inrush current may not be exceeded.

³⁾ The specifications apply only after the bus voltage has been applied to the device for at least 30 seconds. Typical response delay of the relay is approx. 20 ms.

2.4.2 Output lamp load 16/20 A

Lamps	Incandescent lamp load	3680W
Fluorescent lamps T5 / T8	Uncorrected	3680W
	Parallel compensated	2500W
	DUO circuit	3680W
Low-voltage halogen lamps	Inductive transformer	2000 W
	Electronic transformer	2500W
	Halogen lamps 230 V	3680W
Dulux lamp	Uncorrected	3680W
	Parallel compensated	3000W
Mercury-vapour lamp	Uncorrected	3680W
	Parallel compensated	3680W
Switching performance (switch contact)	Maximum peak inrush-current I_p (150 μ s)	600A
	Maximum peak inrush-current I_p (250 μ s)	480A
	Maximum peak inrush-current I_p (600 μ s)	300A
Number of electronic ballasts (T5/T8, single element)¹⁾	18 W (ABB EVG 1 x 18 SF)	26 ²⁾
	24 W (ABB EVG-T5 1 x 24 CY)	26 ²⁾
	36 W (ABB EVG 1 x 36 CF)	22
	58 W (ABB EVG 1 x 58 CF)	12 ²⁾
	80 W (Helvar EL 1 x 80 SC)	10 ²⁾

¹⁾ For multiple element lamps or other types, the number of electronic ballasts must be determined using the peak inrush current of the electronic ballasts, see [Ballast calculation](#), page 35.

²⁾ The number of ballasts is limited by the protection with B16 circuit-breakers.

Device type	Application program	Maximum number of communication objects	Maximum number of group addresses	Maximum number of associations
SA/S 2.16.5.1	Switch 2f 16C/...*	34	254	254
SA/S 4.16.5.1	Switch 4f 16C/...*	64	254	254
SA/S 8.16.5.1	Switch 8f 16C/...*	124	254	254
SA/S 12.16.5.1	Switch 12f 16C/...*	184	254	254

* ... = current version number of the application program

Note

The ETS and the current version of the device application program are required for programming.

The current version of the application program is available for download on the Internet at www.abb.com/knx. After import it is available in the ETS under *ABB/Output/Binary output xf 16C/...** ($x = 2, 4, 8$ or 12).

The device does not support the closing function of a KNX device in the ETS. If you inhibit access to all devices of the project with a BCU code, it has no effect on this device. Data can still be read and programmed.

2.4.3 Connection schematic
SA/S x.16.5.1

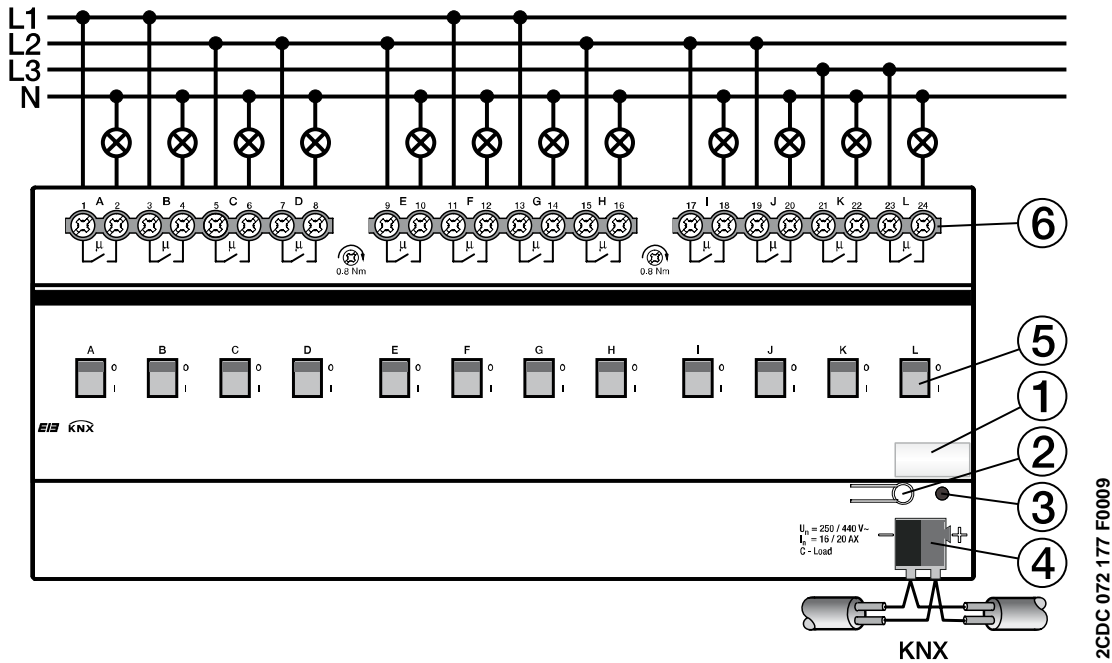

- 1 Label carrier
- 2 Button *Programming*
- 3 LED *Programming*
- 4 Bus connection terminal
- 5 Switch position display and manual operation
- 6 Load circuit, with 2 terminals each

⚠️ ⚡ Danger

Touch voltages.
 Danger of injury.
 Note the all-pole disconnection.

2.4.4 Dimension drawing
SA/S x.16.5.1

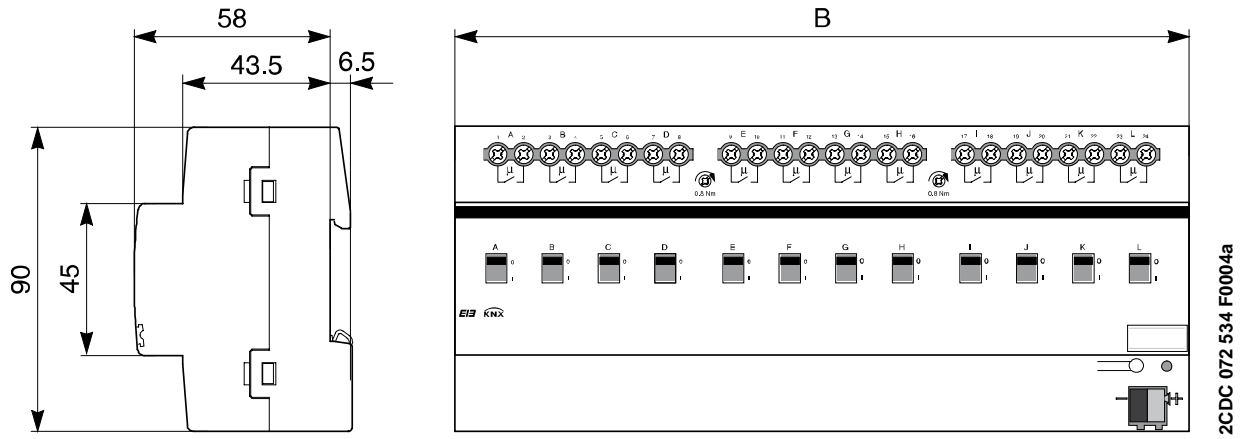

	SA/S 2.16.5.1	SA/S 4.16.5.1	SA/S 8.16.5.1	SA/S 12.16.5.1
Width W	36 mm	72 mm	144 mm	216 mm
Mounting width (modules at 18 mm)	2 space units	4 space units	8 space units	12 space units

**2.5 16/20 A Switch Actuators
SA/S x.16.6.1, MDRC**



2CDC 071 006 S0010

SA/S 8.16.6.1

The 16/20 A Switching actuators SA/S x.16.6.1 are modular installation devices in ProM design for installation in the distribution board. The devices are especially suitable for switching loads with high peak inrush currents such as lighting equipment with compensation capacitors or fluorescent lamp loads (AX) to EN 60 669.

The Switch Actuators feature one load current detection per output. The maximum load current per output is 20 A.

Manual actuation of the Switch Actuator is possible using a button. This simultaneously indicates the switching state.

The Switch Actuators can switch up to 12 independent electrical loads via floating contacts. The maximum load current per output is 20 A. The connection of the outputs is implemented using universal head screw terminals. Each output is controlled separately via the KNX.

Individual outputs can be copied or exchanged to reduce the programming effort with the SA/S x.16.6.1 devices.

The device does not require an additional power supply and is ready for immediate use, after the bus voltage has been applied.

The Switch Actuator is parameterised via ETS. The connection to the KNX is implemented using the bus connection terminal on the front.

2.5.1 Technical data

Supply	KNX-Bus voltage	21...31 V DC			
	Current consumption via bus	< 12 mA			
	Power consumption via bus	Maximum 250 mW			
Output rated value	SA/S type	2.16.6.1	4.16.6.1	8.16.6.1	12.16.6.1
	Current detection	yes	yes	yes	yes
	Number (floating contacts 2/group)	2	4	8	12
	U _n rated voltage	250/440 V AC (50/60 Hz)			
	I _n rated current	16/20 AX, C-Load			
	Leakage loss per device at max. load 16 A	2.0 W	4.0 W	8.0 W	12.0 W
	Leakage loss per device at max. load 20 A	3.0 W	5.5 W	11.0 W	16.0 W
Output switching current	AC3 ¹⁾ operation (cos φ = 0.45) to EN 60 947-4-1	16 A/230 V AC			
	AC1 ¹⁾ operation (cos φ = 0.8) to EN 60 947-4-1	16/20 A/230 V AC			
	Fluorescent lighting load to EN 60 669-1	16/20 AX/250 V AC (200 µF) ²⁾			
	Minimum switching performance	100 mA/12 V AC 100 mA/24 V AC 7 mA/24 V AC			
	DC current switching capacity (resistive load)	20 A/24 V DC			

Output service life	Mechanical service life	> 10 ⁶			
	Electrical endurance to IEC 60 947-4-1				
	AC1 ¹⁾ (240 V/cos φ = 0.8)	> 10 ⁵			
	AC3 ¹⁾ (240 V/cos φ = 0.45)	> 3 × 10 ⁴			
	AC5a ¹⁾ (240 V/cos φ = 0.45)	> 3 × 10 ⁴			
Current detection (load current)	Detection range (sine effective value)	0.02...20 A			
	Accuracy	+/- 2 % of actual current value (sine) and +/- 20 mA			
	Frequency	50/60 Hz			
	2 byte representation (figure value, DTP 7.012) or 4 byte representation (floating value, DTP 14.019)	in mA			
	Measurement speed:				
	– Low-pass filter transient response with τ	300 ms			
– Scanning frequency of the current value	320 ms				
Output switching times³⁾	Maximum relay position change of output and minute if all relays are switched simultaneously. The position changes should be distributed equally within the minute.	2.16.6.1 30	4.16.6.1 15	8.16.6.1 7	12.16.6.1 5
	Maximum relay position change per output and minute if only one relay is switched.	60	60	60	60
Connections	KNX	Via bus connection terminals 0.8 mm Ø, solid			
	Load current circuits (2 terminal per relay)	Universal head screw terminal (PZ 1) 0.2...4 mm ² stranded, 2 x 0.2...2.5 mm ² 0.2...6 mm ² solid, 2 x 0.2...4 mm ²			
	Ferrules without/with plastic sleeves	0.25...2.5/4 mm ²			
	TWIN ferrules	0.5...2.5 mm ² Contact pin length at least 10 mm			
	Tightening torque	Maximum 0.6 Nm			
Operating and display elements	Programming button/LED	For assignment of the physical address			
	Switch position display	Relay operator			
Enclosure	IP 20	To EN 60 529			
Safety class	II	To EN 61 140			
Isolation category	Overvoltage category	III to EN 60 664-1			
	Pollution degree	2 to EN 60 664-1			
KNX safety extra low voltage	SELV 24 V DC				
Temperature range	Operation	-5 °C...+45 °C			
	Storage	-25 °C...+55 °C			
	Transport	-25 °C...+70 °C			

Ambient conditions	Maximum air humidity	95 %, no condensation allowed			
Design	Modular installation device (MDRC)	Modular installation device, ProM			
	SA/S type	2.16.6.1	4.16.6.1	8.16.6.1	12.16.6.1
	Dimensions	90 x W x 64.5 mm (H x W x D)			
	Width W in mm	36	72	144	216
	Mounting width in space units (18 mm unit)	2	4	8	12
	Mounting depth in mm	64.5	64.5	64.5	64.5
Weight	in kg	0.2	0.34	0.64	0.83
Installation	On 35 mm mounting rail	To EN 60 715			
Mounting position	As required				
Housing/colour	Plastic housing, grey				
Approvals	KNX to EN 50 090-1, -2	Certification			
CE mark	In accordance with the EMC guideline and low voltage guideline				

¹⁾ Further information concerning electrical endurance to IEC 60 947-4-1 can be found at: [AC1-, AC3-, AX-, C-Load specifications](#), page 36.

²⁾ The maximum peak inrush current may not be exceeded.

³⁾ The specifications apply only after the bus voltage has been applied to the device for at least 30 seconds. Typical response delay of the relay is approx. 20 ms.

2.5.2 Output lamp load 16/20 A

Lamps	Incandescent lamp load	3680W
Fluorescent lamps T5 / T8	Uncorrected	3680W
	Parallel compensated	2500W
	DUO circuit	3680W
Low-voltage halogen lamps	Inductive transformer	2000 W
	Electronic transformer	2500W
	Halogen lamps 230 V	3680W
Dulux lamp	Uncorrected	3680W
	Parallel compensated	3000W
Mercury-vapour lamp	Uncorrected	3680W
	Parallel compensated	3680W
Switching performance (switch contact)	Maximum peak inrush-current I_p (150 μ s)	600A
	Maximum peak inrush-current I_p (250 μ s)	480A
	Maximum peak inrush-current I_p (600 μ s)	300A
Number of electronic ballasts (T5/T8, single element)¹⁾	18 W (ABB EVG 1 x 18 SF)	26 ²⁾
	24 W (ABB EVG-T5 1 x 24 CY)	26 ²⁾
	36 W (ABB EVG 1 x 36 CF)	22
	58 W (ABB EVG 1 x 58 CF)	12 ²⁾
	80 W (Helvar EL 1 x 80 SC)	10 ²⁾

¹⁾ For multiple element lamps or other types, the number of electronic ballasts must be determined using the peak inrush current of the electronic ballasts, see [Ballast calculation](#), page 35.

²⁾ The number of ballasts is limited by the protection with B16 circuit-breakers.

Device type	Application program	Maximum number of communication objects	Maximum number of group addresses	Maximum number of associations
SA/S 2.16.6.1	Switch 2f 16CS/...*	40	254	254
SA/S 4.16.6.1	Switch 4f 16CS/...*	76	254	254
SA/S 8.16.6.1	Switch 8f 16CS/...*	148	254	254
SA/S 12.16.6.1	Switch 12f 16CS/...*	220	254	254

* ... = current version number of the application program

Note

The ETS and the current version of the device application program are required for programming.

The current version of the application program is available for download on the Internet at www.abb.com/knx. After import it is available in the ETS under *ABB/Output/Binary output xf 16CS/...** (x = 2, 4, 8 or 12).

The device does not support the closing function of a KNX device in the ETS. If you inhibit access to all devices of the project with a BCU code, it has no effect on this device. Data can still be read and programmed.

Important

The Switch Actuator types SA/S x.16.6.1 differentiates from the predecessor types SA/S x.16.5S by new hardware and software. While there have been few changes to the functions of the software, the hardware has been redesigned for load currents up to 20 A. Furthermore, the current detection has been optimised and its accuracy has been enhanced by a factor of four.

Existing projects can be converted to ensure operation with the new hardware / software.

For further information see: [Conversion of previous application program versions, page 47.](#)

For faster and simpler commissioning, it is also possible to copy the parameter settings of the outputs to others or to exchange them with another output.

For further information see: [Copying and exchange of parameter settings, page 50](#)

Note

Only load currents with a sine wave characteristic can be detected correctly. On other signal types, e.g. phase angle or inverse phase angle control signals, the detected current value is distorted. In this case, the measured value is meaningless.

Current values less than 20 mA are indicated as a 0 mA value on the KNX. For small load currents that are just above the minimum detection threshold of 20 mA, it is possible that a value of 0 mA is displayed due to the inaccuracies, even though a current is flowing.

Example: A current of 25 mA is flowing. The Switch Actuator detects 5 mA due to the tolerances. This value is less than the minimum current detection limit of 20 mA and is thus sent as a 0 mA value on the KNX.

Important

The function current detection and monitoring should only be used for safety relevant applications. The Switch Actuator cannot assume the function of a circuit-breaker or RCD (earth-leakage circuit breaker).

If the load current detection is used for equipment fault detection that only causes a slight change of under 30 mA, mains voltage and current fluctuations due to ambient influences, e.g. temperature, natural ageing of the device or a non-sinusoidal current, play a significant role. Even when the current changes are detected by the Switch Actuator, the detected current changes do not necessarily mean that a device has malfunctioned.

2.5.3 Connection schematic
SA/S x.16.6.1

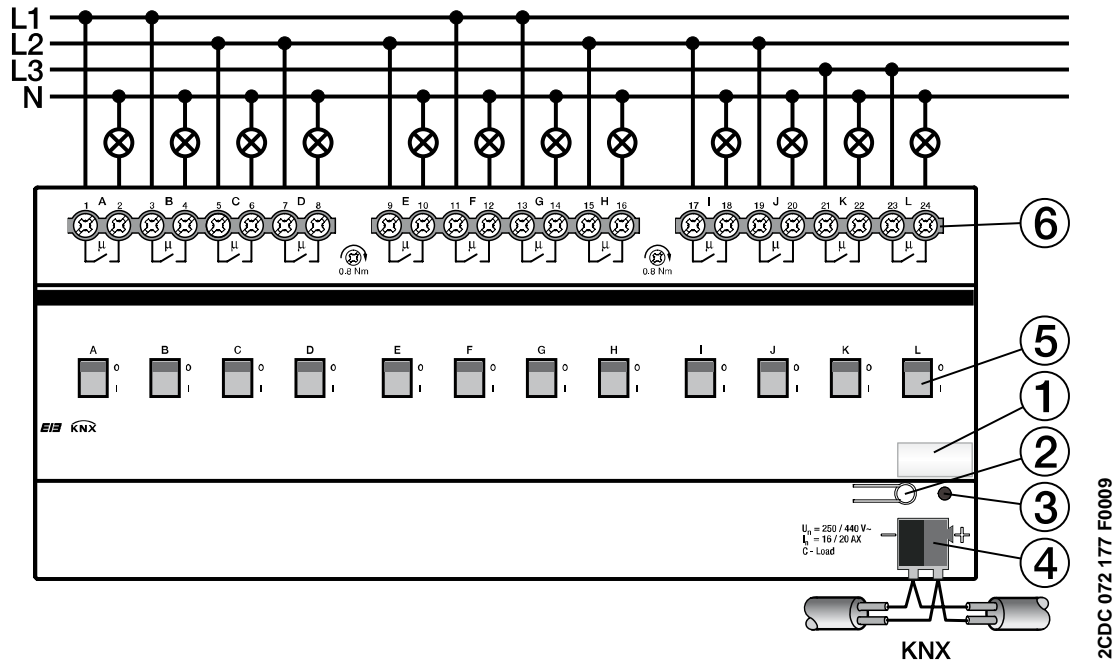

- 1 Label carrier
- 2 Button *Programming*
- 3 LED *Programming*
- 4 Bus connection terminal
- 5 Switch position display and manual operation
- 6 Load circuit, with 2 terminals each

⚠️ ⚡ Danger

Touch voltages.
Danger of injury.
Note the all-pole disconnection.

2.5.4 Dimension drawing
SA/S x.16.6.1

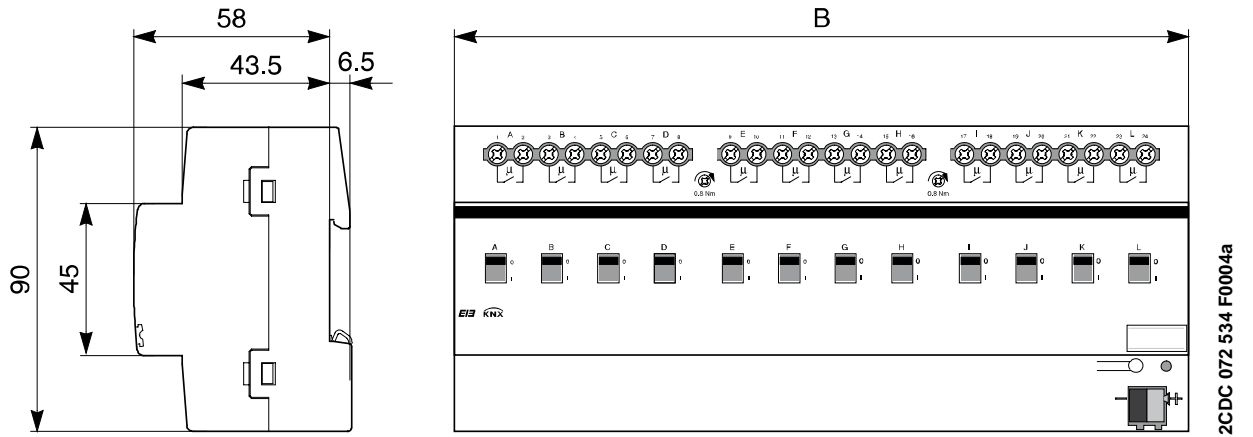

2CDC 072 534 F0004a

	SA/S 2.16.6.1	SA/S 4.16.6.1	SA/S 8.16.6.1	SA/S 12.16.6.1
Width W	36 mm	72 mm	144 mm	216 mm
Mounting width (modules at 18 mm)	2 space units	4 space units	8 space units	12 space units

2.6 Switching capacities overview

The following table shows the switching capacities, lamp loads and/or the number of lamps that can be connected to each contact.

	SA/S 4.6.1.1 SA/S 8.6.1.1 SA/S 12.6.1.1	SA/S 2.10.2.1 SA/S 4.10.2.1 SA/S 8.10.2.1 SA/S 12.10.2.1	SA/S 2.16.2.1 SA/S 4.16.2.1 SA/S 8.16.2.1 SA/S 12.16.2.1	SA/S 2.16.5.1 SA/S 4.16.5.1 SA/S 8.16.5.1 SA/S 12.16.5.1	SA/S 2.16.6.1 SA/S 4.16.6.1 SA/S 8.16.6.1 SA/S 12.16.6.1
I _n rated current (A)	6 A	10 AX	16 A	16/20 AX C-Load	16/20 AX C-Load
U _n rated voltage (V)	250/440 V AC	250/440 V AC	250/440 V AC	250/440 V AC	250/440 V AC
AC1 operation (cos φ = 0.8) EN 60947-4-1	6 A	10 A	16 A	20 A	20 A
AC3 operation (cos φ = 0.45) EN 60947-4-1	6 A	8 A	– ⁴⁾	16 A	16 A
C-Load switching capacity	–	–	–	20 A	20 A
Fluorescent lighting load AX to EN 60669-1	6 A (35 μF) ³⁾	10 AX (140 μF) ³⁾	16 A (70 μF) ³⁾	20 AX (200 μF) ³⁾	20 AX (200 μF) ³⁾
Minimum switching capacity	10 mA/12 V	100 mA/12 V	100 mA/12 V	100 mA/12 V	100 mA/12 V
DC current switching capacity (resistive load)	7 A/24 V =	10 A/24 V =	16 A/24 V =	20 A/24 V =	20 A/24 V =
Mechanical contact endurance	> 10 ⁷	> 3 x 10 ⁶	> 3 x 10 ⁶	> 10 ⁶	> 10 ⁶
Electronic endurance to IEC 60947-4-1:					
– Rated current AC1 (240V/0.8)	100,000	100,000	100,000	100,000	100,000
– Rated current AC3 (240V/0.45)	15,000	30,000	30,000	30,000	30,000
– Rated current AC5a (240V/0.45)	15,000	30,000	30,000	30,000	30,000
Incandescent lamp load at 230 V AC	1200 W	2500 W	2500 W	3680 W	3680 W
Fluorescent lamp T5 / T8:					
– Uncorrected	800 W	2500 W	2500 W	3680 W	3680 W
– Parallel compensated	300 W	1500 W	1500 W	2500 W	2500 W
– DUO circuit	350 W	1500 W	1500 W	3680 W	3680 W
Low-voltage halogen lamps:					
– Inductive transformer	800 W	1200 W	1200 W	2000 W	2000 W
– Electronic transformer	1000 W	1500 W	1500 W	2500 W	2500 W
Halogen lamps 230 V	1000 W	2500 W	2500 W	3680 W	3680 W
Dulux lamps:					
– Uncorrected	800 W	1100 W	1100 W	3680 W	3680 W
– Parallel compensated	800 W	1100 W	1100 W	3000 W	3000 W
Mercury-vapour lamps:					
– Uncorrected	1000 W	2000 W	2000 W	3680 W	3680 W
– Parallel compensated	800 W	2000 W	2000 W	3000 W	3000 W
Sodium vapour lamps:					
– Uncorrected	1000 W	2000 W	2000 W	3680 W	3680 W
– Parallel compensated	800 W	2000 W	2000 W	3000 W	3000 W
Max. peak inrush-current I _p (150μs)	200 A	400 A	400 A	600 A	600 A
Max. peak inrush-current I _p (250μs)	160 A	320 A	320 A	480 A	480 A
Max. peak inrush-current I _p (600μs)	100 A	200 A	200 A	300 A	300 A
Number of electronic ballasts (T5/T8, single element): ²⁾					
18 W (ABB EVG 1 x 18 SF)	10 ballasts	23 ballasts	23 ballasts	26 ¹⁾ ballasts	26 ¹⁾ ballasts
24 W (ABB EVG 1 x 24 CY)	10 ballasts	23 ballasts	23 ballasts	26 ¹⁾ ballasts	26 ¹⁾ ballasts
36 W (ABB EVG 1 x 36 CF)	7 ballasts	14 ballasts	14 ballasts	22 ballasts	22 ballasts
58 W (ABB EVG 1 x 58 CF)	5 ballasts	11 ballasts	11 ballasts	12 ¹⁾ ballasts	12 ¹⁾ ballasts
80 W (Helvar EL 1 x 80 SC)	3 ballasts	10 ballasts	10 ballasts	12 ¹⁾ ballasts	12 ¹⁾ ballasts

¹⁾ The number of ballasts is limited by the protection with B16/20A circuit-breakers.

²⁾ For multiple element lamps or other types the number of electronic ballasts must be determined using the peak inrush current of the electronic ballasts

³⁾ The maximum inrush-current peak may not be exceeded.

⁴⁾ Not intended for AC3 operation; maximum AC3 current see [Technical data](#), from page 7.

2.7 Ballast calculation

The electronic ballast is a device for operating gas discharge lamps, e.g. fluorescent lamps. During normal operation, it converts the mains voltage to an optimum operating voltage for the gas discharge lamps. Furthermore, the electronic ballast enables the gas discharge lamps to ignite (start) via capacitor circuitry.

With the original choke/starter circuitry the lamps switch on consecutively, with the electronic ballast all fluorescent lamps switch on practically simultaneously. If switch on occurs at the mains voltage peak, the buffer capacitor of the electronic ballast cause a high but very short current pulse. When using several ballasts on the same circuit, the simultaneous charging of the capacitors may result in very large system inrush currents.

This peak inrush current I_p is to be considered when designing the switch contacts as well as by the selection of the respective circuit protection. In the following, the effects of the electronic ballast peak inrush current and the associated limitation of the number of electronic ballasts on the SA/S are examined.

The inrush current of the electronic ballast depends not only on the wattage but also on the type, the number of elements (lamps) and on the manufacturer. For this reason, the given maximum number of connectible electronic ballasts per output can only relate to a defined type of electronic ballast. For a different ballast type, this value can only represent an estimation.

In order to properly estimate the number of electronic ballasts, the peak inrush current I_p with the respective pulse width of the electronic ballast must be known. These values should be stated by the manufacturer in the technical data or are available on request by now.

Typical values for single element electronic ballasts with T5/T8 lamps are: Peak inrush current 15...50 A with a pulse time of 120...200 μ s.

The relays of the Switch Actuators have the following maximum starting values:

	SA/S 4.6.1.1 SA/S 8.6.1.1 SA/S 12.6.1.1	SA/S 2.10.2.1 SA/S 4.10.2.1 SA/S 8.10.2.1 SA/S 12.10.2.1	SA/S 2.16.2.1 SA/S 4.16.2.1 SA/S 8.16.2.1 SA/S 12.16.2.1	SA/S 2.16.5.1 SA/S 4.16.5.1 SA/S 8.16.5.1 SA/S 12.16.5.1	SA/S 2.16.6.1 SA/S 4.16.6.1 SA/S 8.16.6.1 SA/S 12.16.6.1
Max. peak inrush current I_p (150 μ s)	200 A	400 A	400 A	600 A	600 A
Max. peak inrush current I_p (250 μ s)	160 A	320 A	320 A	480 A	480 A
Max. peak inrush current I_p (600 μ s)	100 A	200 A	200 A	300 A	300 A

*) x = 5 or 6, C-Load types with and without load current detection

Caution

Do not exceed the threshold values.

Exceeding the value leads to destruction of the relay, e.g. due to welding.

Example

ABB i-bus® ballast 1 x 58 CF

Peak inrush current $I_p = 33.9 \text{ A}$ ($147.1 \mu\text{s}$)

For Switch Actuator SA/S 4.16.6.1 this results in:

maximum number of electronic ballasts/output = $600 \text{ A} / 34 \text{ A} = 17$
electronic ballasts

This number has been limited to 12 electronic ballasts in conjunction with a B16 miniature circuit breaker. If more electronic ballasts are connected, the miniature circuit breaker may trip during switch on.

For Switch Actuator SA/S 4.6.1.1 this results in:

maximum number of electronic ballasts/output = $200 \text{ A} / 34 \text{ A} = 5$
electronic ballasts

2.8 AC1, AC3, AX, C-Load specifications

In Intelligent Installation Systems, different switching capacity and performance specifications that are dependent on the special application have become established in industrial and residential systems. These performance specifications are rooted in the respective national and international standards. The tests are defined so that typical applications, e.g. motor loads (industrial) or fluorescent lamps (residential), are simulated.

The specifications AC1 and AC3 are switching performance specifications, which have become established in the industrial field.

Typical application:

AC1 – Non-inductive or slightly inductive loads, resistive furnaces
(relates to switching of resistive loads, $\cos \varphi = 0.8$)

AC3 – Squirrel-cage motors: Starting, switching off motors during running
(relates to (inductive) motor load, $\cos \varphi = 0.45$)

AC5a – Switching of electric discharge lamps

These switching performances are defined in the standard EN 60947-4-1 *Contactors and motor-starters - Electromechanical contactors and motor-starters*.

The standard describes starters and/or contactors that were previously preferably used in industrial applications.

The designation AX has established itself in the field of building engineering.

AX relates to a (capacitive) fluorescent lighting load.

Switchable capacitive loads ($200 \mu\text{F}$, $140 \mu\text{F}$, $70 \mu\text{F}$ or $35 \mu\text{F}$) is referred to in conjunction with fluorescent lamp loads.

This switching capacity refers to the standard EN 60669 *Switches for household and similar fixed electrical installations*, which deals primarily with applications in building engineering. For 6 A devices a test with $70 \mu\text{F}$ is demanded, and for devices exceeding 6 A a test with $140 \mu\text{F}$ is demanded.

The switching capacity specifications AC and AX are not directly comparable. However, the following switching capacity quality can still be determined:

The lowest switching capacity corresponds with the specification AC1 - mainly for resistive loads.

The following switching capacity should be rated higher AX - fluorescent lighting load to the standard:
70 µF (6 A), 140 µF (10 A, 16 A).

The highest switching capacity is designated by AC3 - motor loads,
C-Load - fluorescent lighting loads (200 µF).

Both specifications are almost equivalent. This means that a device which has fulfilled the test for AC3 to EN 60947 will most probably fulfil the tests to EN 60669 with 200 µF.

In conclusion, the following can be said:

- Users or customers, who are primarily involved with industrial applications, will refer to AC3 switching capacities.
- Users, who are involved with building or lighting technology, will more often than not refer to an AX switching capacity or C-load (200 µF loads).

The switching capacity differences must be considered with the selection of a Switch Actuator.

2.9 Current detection specifications

The Switch Actuators with current detection are recognisable by a number 6 on the third position of the type designation, e.g. SA/S 2.16.6.1.

This is a Switch Actuator with integrated load current detection. Each output features its own current detection with evaluation electronics, which can be parameterised separately.

For further information see: Parameter window [A: Current Detection](#), page 95

The current recognition detects sinusoidal load currents with a frequency range from 45 Hz to 60 Hz. The measured load currents are available as RMS values. Non-sinusoidal currents, e.g. phase angle varied or distorted currents, cause a measurement error depending on the curve type. If a DC current is superimposed, the measurement error is again considerably larger. Phase angle varied currents are generated, for example, by a current rectifier.

The current detection principle in the Switch Actuator is based on the conversion of sinusoidal load currents by a transformer. On the secondary side of the transformer, the transferred value is rectified and smoothed by an RC element. The resulting value is multiplied with the fixed factor $1/\sqrt{2}$ that results in an RMS value. The factor $1/\sqrt{2}$ results from the crest factor $\hat{U}/U_{\text{rms}} = \sqrt{2}$ for a sinusoidal curve type.

For a non-sinusoidal curve type, values result that can greatly diverge from the real RMS value. This measurement method is used in most commercially available analogue and digital multimeters that are calibrated for sinusoidal curve types.

In this case, a true RMS meter or a “non-true RMS meter” are frequently referred to, e.g. METRAHit 13S.

Note

With non-sinusoidal currents, there are considerable differences between a high-quality true RMS meter and the displayed values of the SA/S. For this reason, a meter should be used for comparative measurements that is also calibrated for sinusoidal AC currents.

Only currents exceeding 20 mA can be displayed for technical reasons. Interference is suppressed by an RC element, and the displayed value is stabilised. The RC element has a time constant τ of about 300 ms. The current values are scanned cyclically every 320 ms. Thus a change in the current can be safely detected every 320 ms and sent on the bus if required.

The almost exact value is displayed after $5 \tau \approx 1.5$ s.

The following technical specifications apply for current detection:

Detection range:	0.02...20 A
Accuracy:	+/- 2 % of actual current value +/- 20 mA
Time constant:	300 ms
Scanning frequency:	320 ms
Load current $I_{\text{Load AC}}$:	0...20 A, sinusoidal
$I_{\text{Load DC}}$:	Is not detected
Frequency range:	45...65 Hz
Ambient temperature :	-5 °C...+40 °C

Examples:

Detected current value	Max. inaccuracy
300 mA	+/- 26 mA
2 A	+/- 60 mA
16 A	+/- 340 mA
20 A	+/- 420 mA

For every output, the determined current values can be represented via a 2 byte or 4 byte value output object. The currents are represented in mA as counter values (2 byte, DTP 7.012) or as floating values (4 byte, DTP 14.019).

It is possible to program two threshold values for each output. With an overshoot or undershoot of the current threshold value a 1 bit telegram is sent on the bus. Thus for example, the failure of equipment can be detected and displayed.

With relatively small current values (< 30 mA), natural deviations in the electrical system will be immediately noticeable, e.g. natural ageing of the equipment, voltage fluctuations through differing load levels during the day as well as distortions of the sinusoidal load current, e.g. through switching actions or frequency inverters.

The ideal observation, where the current consumption of the equipment does not change with temperature fluctuations, operating voltage deviations and ageing should be inspected in real systems. The changes of the ambient conditions in practice and the associated changes in current consumption and the monitored equipment must be considered. As ambient influences cannot be eliminated in practice, the detection via a current threshold model is only viable if a current change caused by tolerances and ambient influences in normal operation is less than the current change caused by failure of the equipment.

Recommended approach when monitoring loads that are close to the detection tolerances of the SA/S current detection:

- Connect the complete current circuit on the SA/S output.
- Connect the current circuit and operate the loads in the typical operating range.
- In the ETS, set the data point types of the communication object and start the ETS project group monitor in order to display the current value.
- Observe current value I_A via KNX until a constant current is indicated.
- Cause equipment failure and observe the current value I_F again.
- Determine the difference in current $I_D = I_A - I_F$.
- Compare the difference in current I_D with the current detection tolerances. The current difference must be significantly larger than the accuracy of the current detection (2 % of I_A +/- 20 mA).
- Set the current threshold in SA/S so that it is as near as possible to the determined failure current: $I_A - \frac{1}{2} I_D$ has proven useful.

2.10 Assembly and installation

The ABB i-bus® Switch Actuators are modular installation devices for installation in the distribution board on 35 mm mounting rails to EN 60 715.

The mounting position can be selected as required.

The electrical connection is implemented using screw terminals. The connection to the bus is implemented using the supplied bus connection terminal. The terminal designation is located on the housing.

The device is ready for operation after connection to the bus voltage.

Accessibility of the devices for the purpose of operation, testing, visual inspection, maintenance and repair must be provided compliant to VDE 0100-520.

Commissioning requirements

In order to commission the Switch Actuators, a PC with ETS and an interface, e.g. USB or IP, are required. The device is ready for operation after connection to the bus voltage.

The installation and commissioning may only be carried out by qualified electrical specialists. The appropriate norms, guidelines, regulations and specifications should be observed when planning and setting up electrical installations.

- Protect the device from damp, dirt and damage during transport, storage and operation.
- Only operate the device within the specified technical data limits!
- The device should only be operated in an enclosed housing (distribution board)!

Manual operation

The 10 A and 16 A Switch Actuators have a manual operating feature. The Switch Actuators can be switched ON or OFF with an operating element on the relay. The operating element simultaneously indicates the switch status.

Important

The Switch Actuator does not feature electrical monitoring of the manual actuation and cannot therefore react to manual operation.

From a power engineering point of view, the relay is only actuated with a switching pulse if the known relay position has changed. This has the consequence that after a one-off manual operation, a repeated switching telegram is received via the bus, and no contact changeover occurs. The Switch Actuator assumes that no contact changeover has occurred and that the correct contact position is still set.

An exception to this situation is after bus voltage failure and recovery. In both cases, the relay position is recalculated in dependence on the parameterization and set depending on the contact setting.

Supplied state

The device is supplied with the physical address 15.15.255.

The application program is pre-installed. It is therefore only necessary to load group addresses and parameters during commissioning.

However, the complete application program can be reloaded if required. After a change of application program, after an interrupted download or discharge of the device, a longer downtime may result.

Download behaviour

Depending on the PC, which is used, the progress bar for the download may take up to one and a half minutes before it appears due to the complexity of the device.

Assignment of the physical address

The assignment and programming of the physical address is carried out in the ETS.

The device features a *Programming* button for assignment of the physical device address. The red LED *Programming* lights up after the button has been pushed. It switches off as soon as the ETS has assigned the physical address or the button *Programming* is pressed again.

Cleaning

Dirty devices can be cleaned using a dry cloth or a cloth dampened with a soapy solution. Corrosive materials or solutions should never be used.

Maintenance

The device is maintenance-free. No repairs should be carried out if damage occurs, e.g. during transport and/or storage.

3 Commissioning

All SA/S devices and each of its outputs have the same function with the exception of the current detection. It is thus possible, depending on the application, to freely define every output and to parameterise it accordingly.

The applications feature the same appearance and the same parameter window. This significantly simplifies the engineering and the programming of the ABB i-bus[®] KNX Switch Actuators.

The current detection is only integrated in types SA/S x.16.6.1.

Every Switch Actuator has its own application program with the same functions, whereby devices with current detection feature additional parameters and communication objects for the current detection.

3.1 Overview

The following table provides an overview of the functions with the Switch Actuators and their application programs:

	SA/S 4.6.1.1 SA/S 8.6.1.1 SA/S 12.6.1.1	SA/S 2.10.2.1 SA/S 4.10.2.1 SA/S 8.10.2.1 SA/S 12.10.2.1	SA/S 2.16.2.1 SA/S 4.16.2.1 SA/S 8.16.2.1 SA/S 12.16.2.1	SA/S 2.16.5.1 SA/S 4.16.5.1 SA/S 8.16.5.1 SA/S 12.16.5.1	SA/S 2.16.6.1 SA/S 4.16.6.1 SA/S 8.16.6.1 SA/S 12.16.6.1
Installation type	MDRC	MDRC	MDRC	MDRC	MDRC
Number of outputs	4/8/12	2/4/8/12	2/4/8/12	2/4/8/12	2/4/8/12
Module width (space units)	4/6/8	2/4/8/12	2/4/8/12	2/4/8/12	2/4/8/12
Manual operation	–	■	■	■	■
Contact position display	–	■	■	■	■
I _n rated current (A)	6 A	10 AX	16 A	16/20A	16/20 A
Current detection	–	–	–	–	■
Switch function					
– ON/OFF delay	■	■	■	■	■
– Staircase lighting	■	■	■	■	■
– Warning before end of staircase lighting	■	■	■	■	■
– Staircase lighting time set via object	■	■	■	■	■
– Flashing	■	■	■	■	■
– Switch response can be set (N.O./N.C.)	■	■	■	■	■
– Threshold values	■	■	■	■	■
Current detection	–	–	–	–	■
– Threshold value monitoring	–	–	–	–	■
– Measured value detection	–	–	–	–	■
Function Scene	■	■	■	■	■
Function Logic					
– Logical AND	■	■	■	■	■
– Logical OR	■	■	■	■	■
– Logical XOR	■	■	■	■	■
– Gate function	■	■	■	■	■
Priority object/forced operation	■	■	■	■	■
Heating/blower control					
– Switch ON/OFF (2 point control)	■	■	■	■	■
– Cyclic fault monitoring	■	■	■	■	■
– Automatic purge	■	■	■	■	■
Fan Coil control 1)	■	■	■	■	■
Special functions					
– Default position on bus voltage failure/ bus voltage recovery	■	■	■	■	■
– Status messages	■	■	■	■	■

¹⁾ See special ABB i-bus® KNX devices of the HVAC area, e.g. Valve Drive Actuator, Fan/Fan Coil Actuator or Fan Coil Actuator .

■ = possible functions

The following application programs are available for the Switch Actuators:

Device type	Application program name	Maximum number of communication objects	Maximum number of group addresses	Maximum number of associations
SA/S 4.6.1.1	Switch 4f 6A/...*	64	254	254
SA/S 8.6.1.1	Switch 8f 6A/...*	124	254	254
SA/S 12.6.1.1	Switch 12f 6A/...*	184	254	254
SA/S 2.10.2.1	Switch 2f 10A/...*	34	254	254
SA/S 4.10.2.1	Switch 4f 10A/...*	64	254	254
SA/S 8.10.2.1	Switch 8f 10A/...*	124	254	254
SA/S 12.10.2.1	Switch 12f 10A/...*	184	254	254
SA/S 2.16.2.1	Switch 2f 16A/...*	34	254	254
SA/S 4.16.2.1	Switch 4f 16A/...*	64	254	254
SA/S 8.16.2.1	Switch 8f 16A/...*	124	254	254
SA/S 12.16.2.1	Switch 12f 16A/...*	184	254	254
SA/S 2.16.5.1	Switch 2f 16C/...*	34	254	254
SA/S 4.16.5.1	Switch 4f 16C/...*	64	254	254
SA/S 8.16.5.1	Switch 8f 16C/...*	124	254	254
SA/S 12.16.5.1	Switch 12f 16C/...*	184	254	254
SA/S 2.16.6.1	Switch 2f 16CS/...*	40	254	254
SA/S 4.16.6.1	Switch 4f 16CS/...*	76	254	254
SA/S 8.16.6.1	Switch 8f 16CS/...*	152	254	254
SA/S 12.16.6.1	Switch 12f 16CS/...*	220	254	254

... = The ETS and the current version of the device application program are required for programming. The current version of the application program is available for download on the Internet at www.abb.com/knx. After import it is available in the ETS under ABB/Output/Binary output xf ... (x = 2, 4, 8 or 12).

Programming requires ETS2 version V1.3a or higher.

Note

In this product manual, all the current 2/4/8 and 12-fold Switch Actuators are described. These devices each have 2/4/8 or 12 outputs. However, as the functions for all outputs are identical, only the functions of output A will be described.

Should the details in the product manual refer to all outputs, 2-fold corresponds to outputs A...B, 4-fold corresponds to outputs A...D, 8-fold corresponds to outputs A...H and 12-fold corresponds to outputs A...L, the designation outputs A...X is used.

The variants with current detection feature an additional parameter page as well as additional communication objects for this function.

The following operating modes are available for each output of a Switch Actuator:

Switch Actuator	<p>For "normal" switching, e.g. of lighting.</p> <p>The output is controlled directly via the communication object <i>Switch</i>. A large number of additional functions (time, logic, safety, etc.) are possible.</p> <p><i>For further information see: Planning and application, page 171</i></p>
Heating Actuator	<p>For control of heating valves, e.g. in an individual room temperature control system. A room thermostat sends a control value, which the output uses to control the valve, e.g. as a 2-step control.</p> <p><i>For further information see: Planning and application, page 171</i></p>

Note

With the introduction of optimised current detection, on all Switch Actuator types the nomenclature for status messages, e.g. *Telegr.status switch*, *Thermostat fault*, has been converted to the nomenclature without *Telegr.*, e.g. *Status Switch*, *RTR fault*.

3.1.1 Conversion of previous application program versions

For ABB i-bus® KNX devices from ETS3 or higher, it is possible to assume the parameter settings and group addresses from earlier application programs.

Note
Default values are set for newly added parameters after conversion.

3.1.1.1 Conversion options

The following application programs can be converted:

Device type source device	Application name source device	Convertible to	Device type target device	Application name target device
SA/S 2.16.5S SA/S 4.16.5S SA/S 8.16.5S	Switch 2f 16CS/2.0 Switch 4f 16CS/2.0 Switch 8f 16CS/2.0	→ → →	SA/S x.6.1.1 SA/S x.10.2.1 SA/S x.16.2.1 SA/S x.16.5.1 SA/S x.16.6.1	Switch xf 6A/3.2 Switch xf 10A/3.2 Switch xf 16A/3.2 Switch xf 16C/3.2 Switch xf 16CS/3.2
SA/S 12.16.5	Switch 12f 16C/2.0	Non-convertible		
SA/S 2.20.1S SA/S 4.20.1S SA/S 8.20.1S	Switch 2f 20S/2.0 Switch 4f 20S/2.0 Switch 8f 20S/2.0	→ → →	SA/S x.6.1.1 SA/S x.10.2.1 SA/S x.16.2.1 SA/S x.16.5.1 SA/S x.16.6.1	Switch xf 6A/3.2 Switch xf 10A/3.2 Switch xf 16A/3.2 Switch xf 16C/3.2 Switch xf 16CS/3.2
SA/S 12.20.1 SA/S x.16.1 SA/S x.10.1 SA/S x.6.1	Switch 12f 20A/2.0 Switch xf 16A/2.0 Switch xf 10A/2.0 Switch xf 6A/2.0	Non-convertible		
SA/S x.16.6.1 SA/S x.16.5.1	Switch xf 16CS/3.0, 3.1 oder 3.2 Switch xf 16C/3.1 oder 3.2	→ →	SA/S x.16.6.1 SA/S x.16.5.1 SA/S x.16.2.1 SA/S x.10.2.1	Switch xf 16CS/3.2 Switch xf 16C/3.2 Switch xf 16A/3.2 Switch xf 10A/3.2
SA/S x.16.2.1 SA/S x.10.2.1 SA/S x.6.1.1	Switch xf 16A/3.2 Switch xf 10A/3.2 Switch xf 6A/3.2	→ → →	SA/S x.6.1.1 SA/S x.10.2.1 SA/S x.16.2.1 SA/S x.16.5.1 SA/S x.16.6.1	Switch xf 6A/3.2 Switch xf 10A/3.2 Switch xf 16A/3.2 Switch xf 16C/3.2 Switch xf 16CS/3.2

The following conversions are possible from the point of view of the target devices.

Device type target device	Application name target device	Convertible to	Device type source device	Application name source device
SA/S x.16.6.1	Switch xf 16CS/3.2	←	SA/S x.16.5S SA/S x.20.1S	Switch xf 16CS/2.0 Switch xf 20S/2.0
			SA/S x.16.6.1 (V1.0) SA/S x.16.6.1 SA/S x.16.5.1 SA/S x.16.2.1 SA/S x.10.2.1	Switch xf 16CS/3.0 Switch xf 16CS/3.1 o. 3.2 Switch xf 16C/3.1 o. 3.2 Switch xf 16A/3.2 Switch xf 10A/3.2
SA/S x.16.5.1	Switch xf 16C/3.2	←	SA/S x.16.5S (V2.0) SA/S x.20.1S (V2.0)	Switch xf 16CS/2.0 Switch xf 20S/2.0
			SA/S x.16.6.1 (V1.0) SA/S x.16.6.1 SA/S x.16.5.1 SA/S x.16.2.1 SA/S x.16.2.1	Switch xf 16CS/3.0 Switch xf 16CS/3.1 o. 3.2 Switch xf 16C/3.1 o. 3.2 Switch xf 16A/3.2 Switch xf 10A/3.2
SA/S x.16.2.1	Switch xf 16A/3.2	←	SA/S x.16.5S SA/S x.20.1S	Switch xf 16CS/2.0 Switch xf 20S/2.0
			SA/S x.16.6.1 (V1.0) SA/S x.16.6.1 SA/S x.16.5.1 SA/S x.16.2.1 SA/S x.10.2.1 SA/S x.6.1.1	Switch xf 16CS/3.0 Switch xf 16CS/3.1 o. 3.2 Switch xf 16C/3.1 o. 3.2 Switch xf 16A/3.2 Switch xf 10A/3.2 Switch xf 6A/3.2
SA/S x.10.2.1	Switch xf 10A/3.2	←	SA/S x.16.5S SA/S x.20.1S	Switch xf 16CS/2.0 Switch xf 20S/2.0
			SA/S x.16.6.1 (V1.0) SA/S x.16.6.1 SA/S x.16.5.1 SA/S x.16.2.1 SA/S x.10.2.1 SA/S x.6.1.1	Switch xf 16CS/3.0 Switch xf 16CS/3.1 o. 3.2 Switch xf 16C/3.1 o. 3.2 Switch xf 16A/3.2 Switch xf 10A/3.2 Switch xf 6A/3.2
SA/S x.6.1.1	Switch xf 6A/3.2	←	SA/S x.16.5S SA/S x.20.1S	Switch xf 16CS/2.0 Switch xf 20S/2.0
			SA/S x.16.6.1 (V1.0) SA/S x.16.6.1 SA/S x.16.5.1 SA/S x.16.2.1 SA/S x.10.2.1 SA/S x.6.1.1	Switch xf 16CS/3.0 Switch xf 16CS/3.1 o. 3.2 Switch xf 16C/3.1 o. 3.2 Switch xf 16A/3.2 Switch xf 10A/3.2 Switch xf 6A/3.2
		Non-convertible	SA/S 12.16.5 SA/S 12.20.5 SA/S x.16.1 SA/S x.10.1 SA/S x.6.1	Switch 12f 16C/2.0 Switch 12f 20A/2.0 Switch xf 16A/2.0 Switch xf 10A/2.0 Switch xf 6A/2.0

The version number in brackets refers to the program version of the application.

Important

Normally, the version numbers of our product names correspond with the version numbers of the application programs. There are some exceptions in this respect with Switch Actuators, e.g. with the SA/S 4.16.6.1:

Product name: Switch Actuator, 4-fold, 16A, MDRC (V1.0)

Application program: Switch 4f 16CS/3.0

Important

The Switch Actuator types SA/S x.16.6.1 differentiate from the predecessor types SA/S x.16.5S by new hardware and software. While there have been few changes to the functions of the software, the hardware has been redesigned for load currents up to 20 A. Furthermore, the current detection has been optimised and its accuracy has been enhanced by a factor of four.

In order to minimise the programming effort, in the SA/S x.16.6.1 and SA/S x.16.5.1 it is possible to copy or exchange the parameterization of an output.

Note

If the number of outputs of the target device is larger than the number of outputs of the source device, only the first outputs of the target device are written with the converted data of the source device. The remaining outputs retain the default values or are reset to the default values.

3.1.1.1.1 Conversion summary

- All applications *Switch.../3.1 or 3.2* (SA/S x.16.y.1 with or without current detection) are mutually convertible.
- The applications *Switch...CS/2.0* (SA/S x.16.5S with current detection!) are permissible as a source.
- The application *Switch 12f 16C/2.0* (SA/S 12.16.5 12-fold device without current detection) is not possible as a source.
- The general rules covering conversion apply (parameters in the source device, which do not exist in the target device, are ignored. Parameters in the target device, which do not exist in the source device, receive their default value).

3.1.1.2 Procedure

- Import the current VD3 file into ETS3 and add a product with the current application program to the project.
- After you have parameterized a device, you can transfer the settings to a second device.
- Right click on the product and select *Convert*.

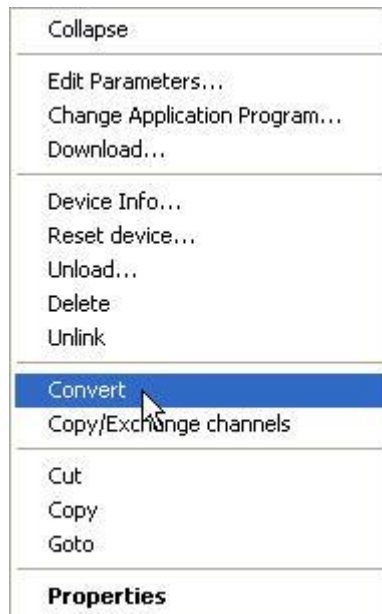

- Subsequently, the required settings are undertaken in the dialog.
- Finally, exchange the physical address and delete the old device.

Should you wish to only copy individual channels within a device, use the function [Copy and exchange](#), page 50.

3.1.2 Copying and exchanging parameter settings

Note

The copy and exchange function of outputs is integrated into all Switch Actuators .

Parameterization of devices can take a lot of time depending on the complexity of the application and the number of device outputs. To keep the commissioning work to the minimum possible, using the function *Copy/exchange channels*, parameter settings of an output can be copied or exchanged with freely selectable outputs. Optionally, the group addresses can be retained, copied or deleted in the target output.

The copy function of outputs is particularly useful with Switch Actuators that have several outputs with the same parameter settings. For example, lighting in a room is frequently controlled in an identical manner. In this case, the parameter settings from output X of a Switch Actuator can be copied to all other outputs or to a special output of the Switch Actuator. Thus the parameters for this output must not be set separately, which significantly shortens the commissioning time. The copy function is available for all SA/S x.x.x.1.

The exchange of parameter settings is useful, e.g. should the outputs be swapped when wiring the terminals. The parameter settings of the incorrectly wired outputs can be simply exchanged saving the requirement for time-consuming rewiring.

3.1.2.1 Procedure

- Import the current VD3 file into ETS3 and add a product with the current application program to the project.
- Click with the right mouse button on the product whose outputs you wish to copy or exchange and select the context menu *Copy/exchange channels*.

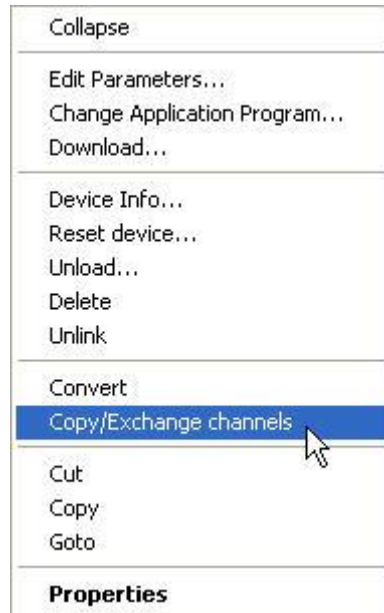

Subsequently the required settings are undertaken in the dialog *Copy/exchange channel*.

Note

When the term “channels” is used in the ETS, inputs and/or outputs are meant. In order to ensure that the ETS language generally applies for as many ABB i-bus® devices as possible, the word channels is used here.

3.1.2.2 Dialog Copy/exchange channel

The dialog box is titled "Dialog Copy/exchange channel". It is divided into two main sections. The top section has two columns: "Source channel" and "Destination channels". Both columns contain a list box with "Output A" and "Output B". Below the "Destination channels" list box are two buttons: "All" and "None". The middle section contains three radio buttons: "Keep group addresses in the destination channel unchanged (if possible)" (selected), "Copy group addresses", and "Delete group addresses in the destination channel". A "Copy" button is located to the right of the second and third radio buttons. The bottom section contains three radio buttons: "Exchange without group addresses", "Exchange with group addresses" (selected), and "Delete group addresses". An "Exchange" button is located to the right of the second and third radio buttons. At the bottom of the dialog are "OK" and "Cancel" buttons.

You can see general product information in the upper area of the window.

Below it you will find a selection window for the source channel in order to mark the source channel. Beside is located the selection window for the target channel or channels for marking the target channel or channels.

Source channel

With the selection of the source channel, you define which parameter settings should be copied or exchanged. Only one source channel can be selected at a time.

Target channels

With the selection of the target channels, you define which channel/channels are to assume the parameter settings of the source channel.

- For the function *Exchange*, only one target output can be selected at a time.
- For the function *Copy*, different target channels can be selected simultaneously. For this purpose, press the Ctrl key and mark the required channels, e.g. channel B and H, with the mouse cursor.

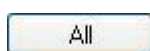

With this button, you select **all** available target channels, e.g. A...H.

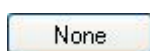

Reset the selection of the target channel with this button.

Copy

The following options can be selected before copying the parameter settings:

- Leave the group addresses unchanged (if possible) in the target channel
- Copy group addresses
- Delete group addresses in the target channel

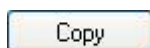

With this button, copy the settings of the source channel into the target channel or channels.

Exchange

The following options can be selected before exchanging the parameter settings:

- Retain group addresses
- Exchange of group addresses
- Deletion of group addresses

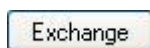

With this button, exchange the settings of the source channel with the target channel.

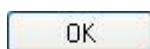

Confirm your selection with this button, and the window closes.

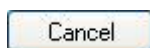

Using this button, the window closes without accepting the changes.

3.2 Parameters

The parameterization of the Switch Actuator is implemented using the Engineering Tool Software ETS from version ETS2 V1.3 or higher. The application program can be found in the ETS2 / ETS3 at ABB/Output/Binary output/Switch xf 6A/..., xf 10A/..., xf 16A/..., xf 16C/... or xf 16CS/...

The following chapter describes the parameters of the Switch Actuators using the parameter window. The parameter window features a dynamic structure, so that further parameters may be enabled depending on the parameterization and the function.

The default values of the parameters are underlined, e.g.

Options: yes
 no

Note

In this product manual, all the current 2/4/8 and 12-fold Switch Actuators are described. These devices each have 2/4/8 or 12 outputs. However, as the functions for all outputs are identical, only the functions of output A will be described.

Should the details in the product manual refer to all outputs, 2-fold corresponds to outputs A...B, 4-fold corresponds to outputs A...D, 8-fold corresponds to outputs A...H and 12-fold corresponds to outputs A...L, the designation outputs X is used.

The variants with current detection feature an additional parameter page as well as additional communication objects for this function.

3.2.1 Parameter window *General*

Higher level parameters can be set in the *General* parameter window.

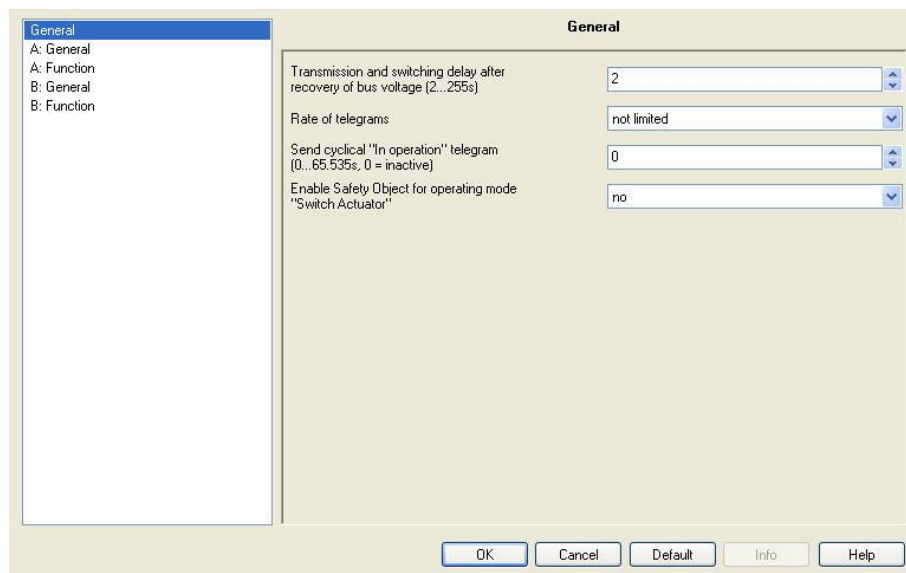

Transmission and switching delay after recovery of bus voltage [2...255s]

Options: 2...255

Telegrams are only received during the send and switching delay. The telegrams are not processed however, and the outputs remain unchanged. No telegrams are sent on the bus.

After the sending and switching delay, telegrams are sent, and the state of the outputs is set to correspond to the parameterization or the communication object values.

If communication objects are read during the sending and switching delay, e.g. by a visualisation system, these read requests are stored, and a response is sent, after the send and switching delay has been completed.

An initialisation time of about two seconds is included in the delay time. The initialisation time is the time that the processor requires to be ready to function.

How does the device behave with bus voltage recovery?

After bus voltage recovery, the device always waits for the send delay time to elapse before sending telegrams on the bus.

Rate of telegrams

Options: not limited
1 Telegram / Second
2 Telegrams / Second
3 Telegrams / Second
5 Telegrams / Second
10 Telegrams / Second
20 Telegrams / Second

The load on the bus generated by the device can be limited with the limitation on the number of telegrams sent. This limit relates to all telegrams sent by the device.

- *x* Telegrams / Second*: Within a second, x telegrams are sent as quickly as possible on the bus.

Note

The device counts the number of telegrams sent within a second. As soon as the maximum number of sent telegrams is reached, no further telegrams are sent on the KNX until the end of the second. The telegram counter is reset to zero, and sending of telegrams is allowed again after the second has timed-out. The current communication object value is always sent at the time of transmission.

Example:

Maximum number of sent telegrams = 5,
20 telegrams are ready to be sent. The device immediately sends 5 telegrams. The next 5 telegrams are sent after a maximum of 1 second. From this point, a further 5 telegrams are sent on the KNX every second.

x = 1,2,3,5,10 or 20

**Send cyclical "In operation" telegram
(0..65,535s, 0 = inactive)"**

Options: 0..65,535

The *in operation* communication object indicates the correct function of the device on the bus. This cyclic telegram can be monitored by an external device.

Note

After bus voltage recovery, the communication object sends its value after the set sending and switching delay.

In order to keep the bus load to a minimum, the time interval of the send interval must be selected as long as possible in dependence on the application.

**Enable Safety Object for operating mode
"Switch Actuator"**

Options: no
 yes

- yes: Three further parameters appear:

Function Safety Priority 1**Function Safety Priority 2****Function Safety Priority 3**

Options: inactive
 Is triggered by object value "0"
 Is triggered by object value "1"

Note

The functions and setting options of the parameter *Function Safety Priority 2* and *Function Safety Priority 3* do not differentiate from those of parameter *Function Safety Priority 1*.

In Switch Actuator mode, there are three *Function Safety Priority x** parameters available. For every priority, your own trigger condition (safety disconnection) can be defined here. With safety disconnection, 1 communication object *Safety Priority x** becomes visible each time. These communication objects relate to the entire device. However, every output can react differently to the receipt of a telegram. The reaction of the output is parameterised in the parameter window *X: Safety* of the corresponding output.

*x = 1, 2 or 3

- *inactive*: The function *Safety Priority x* is not used.
- *Is triggered by object value "0"*: Activation of the safety is triggered if at communication object *Safety Priority x** a telegram with the value 0 is received. The following parameter appears.
- *Is triggered by object value "1"*: Activation of the safety is triggered if at communication object *Safety Priority x** a telegram with the value 1 is received. The following parameter appears:

**Control period in seconds
(0...65,535s, 0 = inactive)**

Options: 0...65,535

This parameter defines the control period of the function *Safety Priority x*. If a telegram is received in this time with the defined triggering condition as defined in parameter *Function Safety Priority x*, on communication object *Safety Priority x**, it will be triggered. Should the communication object *Safety Priority x** receive a telegram that does not fulfil the trigger conditions, the control period is reset and restarted.

- 0: There is no monitoring. However, the *Safety Priority x* is triggered when a telegram with the defined triggering condition, as defined in parameter *Function Safety Priority x*, on communication object *Safety Priority x** is received.

*x = 1, 2 or 3

Note

The control period in the Switch Actuator should be at least twice as long as the cyclical transmission time of the sensor, so that the immediate absence of a signal, e.g. due to a high bus load, does not immediately result in an alarm.

3.2.2 Parameter window A: General

Note

In this product manual, all the current 2/4/8 and 12-fold Switch Actuators are described. These devices each have 2/4/8 or 12 outputs. However, as the functions for all outputs are identical, only the functions of output A will be described.

In this parameter window, all general settings for output A are undertaken.

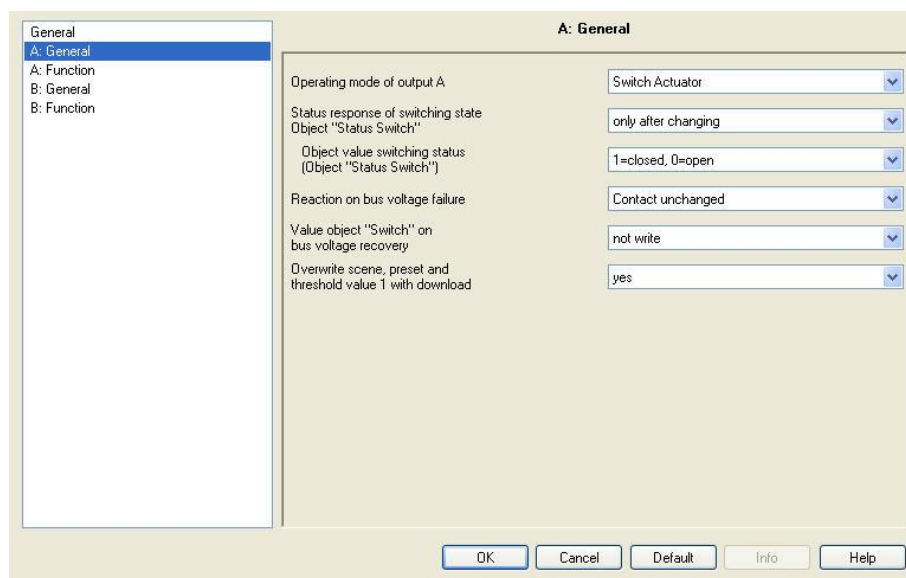

Operating mode of output

Options: Switch Actuator
Heating Actuator

This parameter defines the operating mode of the output. As the parameter and possible functions as well as other parameter windows are different for each operating mode, we will describe them for each operating mode:

- [Operating mode Switch Actuator](#), from page 61
- [Operating mode Heating Actuator](#), from page 149

3.2.3 Operating mode *Switch Actuator*

The operating mode *Switch Actuator* is used for normal switching, e.g. of lighting. The output is controlled via various logic, time and safety functions. The input signal for the function is received via communication object *Switch*. The Switch Actuator carries out the function independently and controls the corresponding relay.

The comprehensive range of additional functions available is described in this chapter.

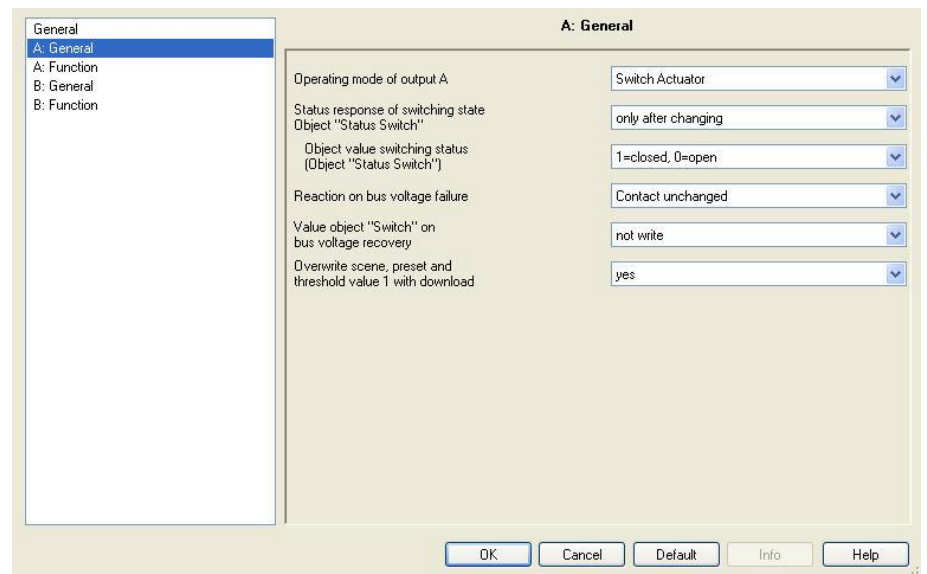

Status response of switching state Object "Status Switch"

Options: no
 after a change
 always

This parameter can enable the communication object *Status Switch*. This contains the current switching state and the present contact position.

- *no*: The switch state is updated but the status is not actively sent on the bus.
- *after a change*: With a change of the switch state, the status is actively sent on the bus via the communication object *Status Switch*. This can have a major affect on the bus load on a Switch Actuator with several outputs.

- *always*: The status of the switch state is always actively sent on the bus via the communication object *Status Switch*, even when a change in status has not occurred. Transmission is triggered as soon as the communication objects *Switch*, *Threshold input* or *Permanent ON* receive a telegram. Even a scene or preset recall trigger transmission of the switch state.
 On the SA/S x.16.6.1 with the option *always*, the status is changed if a telegram is received on the logic objects *Logical connection 1* or *Logical connection 2*.
 A status repetition is not repeated or resent by a safety change (forced operation, priority) for all types.

Note

<p>With a change of the parameterization or after a subsequent switching of the status object, the assignment of the group addresses already allocated to the <i>Switch</i> communication object is lost and needs to be reprogrammed.</p>
--

The status value to be sent is defined with the parameter *Object value switching status (Object "Status Switch")*.

Note

<p>The contact position results from the sequence of priorities and logical connections; refer for this purpose to Function chart, page 192.</p>
--

<p>The contact position can only be correctly evaluated should the switching actions occur via KNX. The SA/S cannot differentiate between manual switching and a cable break or device fault.</p>

Object value switching status (Object "Status Switch")

Options: 1=closed, 0=open
 0=closed, 1=open

- *1=closed, 0=open*: The value 1 is written with a closed contact, and the value 0 is written with an open contact in the communication object *Status Switch*.
- *0=closed, 1=open*: The value 0 is written with a closed contact, and the value 1 is written with an open contact in the communication object *Status Switch*.

Reaction on bus voltage failure

Options: Contact open
 Contact closed
 Contact unchanged

The output can adopt a defined state on bus voltage failure with this parameter.

For further information see: [Reaction on bus voltage failure, recovery and download](#), page 197

Value object "Switch" on bus voltage recovery

Options: not write
 write with 0
 write with 1

With this parameter, the output can be influenced after bus value recovery. As standard, the communication object *Switch* contains value 0.

- *not write*: After bus voltage recovery, the value 0 remains in the communication object *Switch*. The switch state is not re-determined.

Note

Before the initial download (device ex-works), the value before bus voltage failure is not defined. For this reason, the communication object *Switch* is written with 0 and the contact is opened.

If opening of the contact at bus voltage recovery before the initial download (construction phase) is not desired, it can be prevented by temporary removal of the KNX voltage.

- *write with 0*: The communication object *Switch* is written with a 0 at bus voltage recovery. The contact position is redefined and reset in dependence on the set device parameterization.
- *write with 1*: The communication object *Switch* is written with a 1 at bus voltage recovery. The contact position is redefined and reset in dependence on the set device parameterization.

Note

Provided that no manual switching actions has occurred, the communication object *Status Switch* indicates the correct status of the contact position independently of the value of the communication object *Switch*.

The Switch Actuator draws the energy for switching the contact from the bus. After bus voltage is applied, sufficient energy is only available after about 10 to 30 seconds to switch all contacts simultaneously, see [Technical data](#) from page 7.

Depending on the set delay time in the parameter *Transmission and switching delay after recovery of bus voltage* of the parameter window *General*, the individual outputs assume the desired contact position only after this delay time has timed-out. If a shorter delay time is set, the Switch Actuator will only switch the first contact when sufficient energy is stored in the Switch Actuator, in order to ensure that enough energy is available to immediately bring all outputs safely to the required position with a renewed bus voltage failure

Overwrite scene, preset and threshold value 1 with download

Options: no
 yes

With this parameter, you determine whether the preset and scene values and the threshold value 1 of the output modified via the bus are overwritten in the Switch Actuator in Parameter window *A: Scene*, *A: Preset*, *A: Threshold value* set values.

- *yes*: In the parameter window *A: Scene*, *A: Preset*, *A: Threshold value*, set values are transferred with a download to the Switch Actuator, and the existing values are overwritten. Reprogramming of these values via the bus is still possible at any time.
- *no*: In the parameter window *A: Scene*, *A: Preset*, *A: Threshold value*, set values are not transferred with a download to the Switch Actuator. The values can only be changed and set via the bus.

For further information see: Parameter window [A: Scene](#), page 83, [A: Preset](#), page 80 and [A: Threshold value](#), page 92

3.2.3.1 Parameter window A: Function

In this parameter window, you determine the behaviour of the output and can enable different functions, where further parameters windows become available.

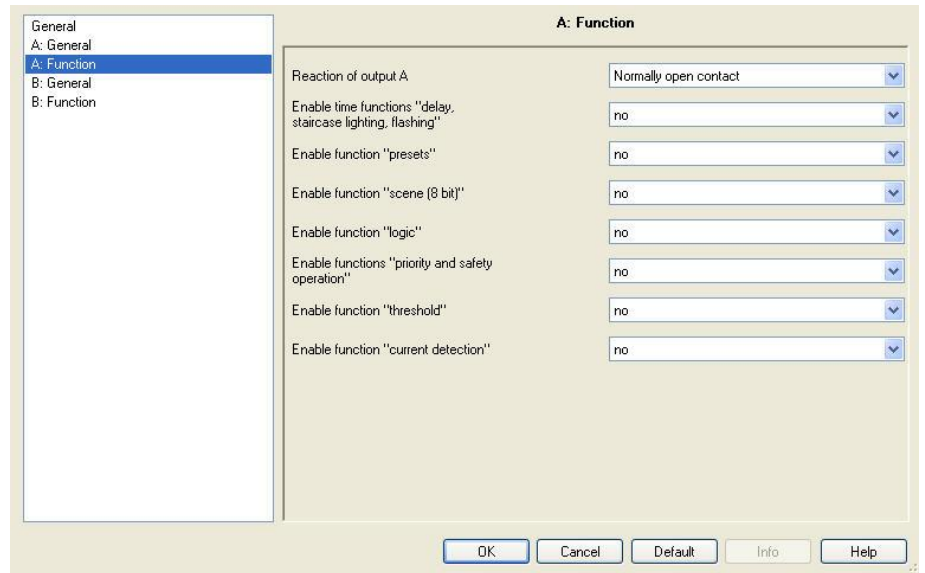

Reaction of output

Options: Normally closed contact
Normally open contact

This parameter determines the behaviour of the output as a normally open or normally closed contact.

- *Normally closed contact*: An ON telegram (1) opens the contact and an OFF telegram (0) closes the contact.
- *Normally open*: An ON telegram (1) closes the contact and an OFF telegram (0) opens the contact.

Enable time functions: "delay, staircase lighting, flashing"

Options: no
yes

- *no*: The parameter window *A: Time* for output A is not enabled.
- *yes*: The parameter window *A: Time* for output A as well as the communication object *Time function disable* is enabled. Using this communication object, the function *Time* can be enabled (telegram with value 0) or disabled (telegram with value 1) via the bus.

As long as the function *Time* is disabled, the output can only be switched on and off without delay via the communication object *Switch*.

The priorities as listed in [Function chart](#), page 177, still remain valid.

Note

The function *Time* is only disabled after the ongoing function *Time* has ended.

During disabling of the output, the higher switching priorities, e.g. the functions *Safety*, are undertaken.

After the function *Time* has been enabled, the communication object *Permanent ON* is enabled. The output is switched ON via this communication object. It remains switched ON until a telegram with the value 0 is received by the communication object *Permanent ON*. The functions continue to operate in the background during the *Permanent ON* phase. The contact position at the end of the *Permanent ON* phase results from the functions operating in the background.

With the selection *yes* a new parameter appears:

Value object "Disable Time Function" after bus voltage recovery

Options: "1", disable time functions
"0", enable time functions

- "1", *disable time functions*: The function *Time* is disabled by a telegram with the value 1.

Note

They can only be enabled via the communication object *Disable Time Function*.

- "0", *enable time function*: The function *Time* is enabled by a telegram with the value 0.

Note

The timing continues to the end. Only then is the function *Time* no longer active.

How does the staircase light behave with bus voltage failure?

The behaviour at bus voltage failure is determined by the parameter *Reaction on bus voltage failure* in the parameter window *A: Output*.

How does the staircase light behave with bus voltage recovery?

The *Reaction on bus voltage recovery* is defined by two conditions:

- A By the communication object *Time function disable*. If the staircase lighting is disabled after bus voltage recovery, the staircase lighting can only be switched on or off via the communication object *Switch*.
- B Using the parameterization of the communication object *Switch*. Whether the light is switched on or off with bus voltage recovery depends on the programming of the communication object *Switch*.

Enable function "presets"

Options: no
 yes

- *no*: The parameter window *A: Preset* for output A is not enabled.
- *yes*: The parameter window *A: Preset* for output A is enabled.

Enable function "scene (8 bit)"

Options: no
 yes

- *no*: The parameter window *A: Scene* for output A is not enabled.
- *yes*: The parameter window *A: Scene* for output A is enabled.

Enable function "logic"

Options: no
 yes

- *no*: The parameter window *A: Logic* for output A is not enabled.
- *yes*: The parameter window *A: Logic* for output A is enabled.

Enable functions "priority and safety operation"

Options: no
 yes

- *no*: The parameter window *A: Safety* for output A is not enabled.
- *yes*: The parameter window *A: Safety* for output A is enabled. In this parameter window, the safety priorities 1, 2, 3 and forced operation are parameterized.

Enable function "threshold"

Options: no
 yes

- *no*: The parameter window *A: Threshold* for output A is not enabled.
- *yes*: The parameter window *A: Threshold* for output A is enabled.

Enable function "current detection"

Options: no
 yes

- *no*: The parameter window *A: Current detection* for output A is not enabled.
- *yes*: The parameter window *A: Current detection* for output A as well as the communication object *Contact monitoring* are enabled.

Note

These parameters and their functions are only visible for Switch Actuators with current detection. The actuators with integrated current detection are recognisable by a number 6 on the third position of the type designation, e.g. SA/S 2.16.6.1.

Send status via object "contact monitoring"

Options: no
 after a change
 always

The sending behaviour of the communication object *Contact monitoring* can be parameterized by the parameter. A contact fault is indicated via the communication object *Contact monitoring*. An error (value 1) is displayed as soon as a current of about 30 mA (observe the tolerances) is detected with an open contact.

- *no*: The value of the communication object is always updated but not sent.
- *always*: The switch status is updated and always sent, when there is a change of status or the contact is to be opened and is not yet open. No value is sent when closing the contact. The reset status is only sent with the next opening.
- *after a change*: A telegram is only sent if the value of the communication object *Contact monitoring* changes. Here the bus load, particularly for Switch Actuators with multiple outputs, can be influenced significantly.

Important

The contact position can only be correctly evaluated should the switching actions occur via KNX. The SA/S cannot differentiate between manual switching and a cable break or device fault. Evaluation of the contact monitoring occurs about two seconds after opening the contact.

3.2.3.1.1 Parameter window A: Time

In this parameter window, all settings for the function *Time* are undertaken: *Switching ON and OFF delay*, *Staircase lighting* and *Flashing*.

This parameter is visible if in parameter window [A: Function](#), page 65, the parameter *Function Time* has been enabled.

A: Time	
Time function	Staircase lighting function
Duration of staircase lighting Minutes (0..1000)	5
Seconds (0..59)	0
Extending staircase lighting by multiple operation ("pumping up")	yes (retriggerable)
Staircase lighting can be switched off	ON with "1" and OFF with "0"
Warning before end of staircase lighting	via object
Warning time in sec. (0..65.535) add to duration of staircase lighting	45
Duration of staircase lighting can be changed by object	no
Restart of staircase time after end of permanent ON	no

Explanations concerning the time functions and the timing sequences can be found under [Planning and application](#), page 171. Please observe the [Function chart](#), page 177, from which the switching and timing priorities originate.

Time function

Options: Staircase lighting function
Switching ON and OFF delay
Flashing

This parameter defines the type of *Function Time* for each output.

- *Staircase light*: The value, with which the staircase lighting is switched on and off, can be parameterized. The staircase lighting time is started when the function is activated. It is switched off immediately after the staircase lighting time has been completed.

Note

Switch on means the closing of a normally open contact or opening of a normally closed contact.

The function *Staircase lighting* can also be called via the communication object *Switch*, *Logical connection x* ($x = 1, 2$) or called with a light scene recall.

With a telegram to the communication object *Disable time function*, the function *Time* can be disabled.

The parameterization is undertaken in parameter window [A: Function](#), page 65, with the parameter *Value object "Disable Time Function" after bus voltage recovery*.

- *ON/OFF delay*: The output can be switched on or off with a delay via this function.
- *Flashing*: The output starts to flash as soon as the parameterized value is received in the communication object *Switch*. The flashing period can be adjusted via the parameterized time duration for ON or OFF. At the start of the flashing period, the output is switched on with a normally open contact and off with a normally closed contact. When a new value is received on the communication object *Switch*, the flashing period will recommence.

The relay state after flashing can be programmed.

Flashing can be inverted when the output is used as a normally closed contact.

The communication object *Status switch* indicates the current relay state during flashing.

Note

With a telegram to the communication object *Disable time function*, the function *Flashing* can be disabled.

The parameterization is undertaken in parameter window [A: Function](#), page 65, with the parameter *Value object "Disable Time Function" after bus voltage recovery*.

The following parameter appears with the selection *Staircase lighting*:

Duration of staircase lighting**Minutes (0...1000)**

Options: 0...5...1,000

Seconds

Options: 0...59

The staircase lighting time defines how long the contact is closed – provided that the contact is programmed as a normally open contact – and how long the light remains on after an ON telegram. The input is made in minutes and seconds. The staircase lighting time may extend depending on the value set in the parameter *Warning before end of staircase lighting*.

Extending staircase lighting by multiple operation (“pumping up”)

Options: no (not retriggerable)
yes (retriggerable)
up to max. 2x staircase lighting time
up to max. 3x staircase lighting time
up to max. 4x staircase lighting time
up to max. 5x staircase lighting time

If a further ON telegram is received during the staircase lighting time sequence, the remaining staircase lighting time can be extended by a further period. This is possible by repeated operation of the push button (“pumping up”) until the maximum programmed number of retriggering operations is reached. The maximum time can be set to 1, 2, 3, 4 or 5-fold time of the staircase lighting time.

The staircase lighting time is extended by “pumping up” to the maximum time. If some of the time has already timed out, the staircase lighting time can again be extended to the maximum time by “pumping up”.

The parameterised maximum time may not however be exceeded.

- *no*: The receipt of an *ON telegram* is ignored.
Die Treppenlichtzeit läuft unverändert zu Ende.
- *yes (retriggerable)*: The staircase light time is reset each time by a renewed *ON telegram* and starts to count again each time. This process can be repeated as often as desired using this selection.
- *Up to max. 2/3/4/5 x staircase lighting time*: The staircase lighting time is extended by the 2/3/4/5-fold staircase lighting time with a renewed ON telegram.

Staircase lighting can be switched

Options: ON with 1 and OFF with 0
ON with 1 no action with 0
ON with 0 or 1, switch OFF not possible

This parameter defines the telegram value used for switching the staircase lighting on and off prematurely.

- *ON with 0 or 1, switch OFF not possible*: The function *Staircase lighting* is switched on independently of the value of the incoming telegram. Premature switch off is not possible.

Note

After enabling the *Function time* via the communication object *Disable time function*, the contact position of the enabled output remains unchanged. *Function Time* is only triggered after the next switching telegram. This means however, should the option *ON with "1" no action "0"* be parameterized, the output is switched on simultaneously with enable. Switch off via the bus is thus not possible. Only after, e.g. the function *Staircase lighting* is started, does the output switch off, after the staircase lighting time has elapsed.

Warning before end of staircase lighting

Options: no
via object
via quick switching OFF/ON
via object and switching ON/OFF

Before the staircase lighting time times-out, the user can be informed of the imminent switch off of the lighting by a warning. If the warning time is not equal to 0, the staircase lighting time is extended by the warning time. The warning time is not modified by the pumping action.

- *no*: No warning is given, the staircase light switches off immediately after the staircase lighting time elapses. If the staircase lighting is ended prematurely, e.g. by a switching telegram, no warning is given.

There are two types of warning:

1. The communication object *warning stair lighting* is set to the value 1 at the commencement of warning time and remains so until the warning time has elapsed. The communication object can be used, for example, to switch a warning light.
2. Switching the output (briefly OFF and ON again).

Both possibilities can be set together or separately. The time duration between the OFF and ON process is about 1 second. If the warning time is not equal to 0, the staircase lighting time is extended by the warning time.

Note

When dealing with the warning time, it is important to remember that the SA/S draws its switching energy exclusively via the KNX. Furthermore, the SA/S collects enough energy before the first switching to ensure that all outputs can safely go to the required position should the bus voltage fail. Under these conditions, only a certain number of switching actions are possible per minute, see [Technical data](#), from page 7.

Warning time in sec. (0...65,535) add to duration of staircase lighting

Options: 0...45...65,535

This parameter is visible if a warning is programmed before the staircase lighting time ends. The warning time must be entered in seconds. The staircase lighting time is extended by the warning time. The warning is triggered at the start of the warning time.

The warning time is not modified by “pumping up”.

Duration of staircase lighting can be changed by object

Options: no
yes

- *yes*: A 2 byte communication object *Duration of staircase lighting* is enabled. The staircase lighting time can be changed via the bus here. The value defines the staircase lighting time in seconds. The function *Staircase lightning* that has already commenced is completed. A change of the staircase lighting time is used the next time it is accessed.
- *no*: No modification of the staircase lighting time is possible via the bus.

Note

With a bus voltage failure, the staircase lighting time changed via the bus is lost and must be reset. Until a new value is set, the staircase lighting time programmed via the ETS applies.

How does the staircase light behave with bus voltage failure?

The behaviour at bus voltage failure is determined by the parameter *Reaction on bus voltage failure* in the parameter window *A: Output*.

How does the staircase light behave with bus voltage recovery?

The reaction at bus voltage recovery is defined by two conditions:

- A By the communication object *Time function disable*. If the staircase lighting is disabled after bus voltage recovery, the staircase lighting can only be switched on or off via the communication object *Switch*.
- B Using the parameterization of the communication object *Switch*. Whether the light is switched on or off with bus voltage recovery depends on the programming of the communication object *Switch*.

Restart of staircase time after end of permanent ON

Options: no
 yes

- *no*: The lighting switches off if *Permanent ON* is ended.
- *yes*: The lighting remains on, and the staircase lighting time restarts.

The function of continuously ON is controlled via the *Permanent ON* communication object value. If the communication object receives a telegram with the value 1, the output is switched ON irrespective of the value of the communication object *Switch* and remains switched on until the communication object *Permanent ON* has the value 0.

Note

Permanent ON only switches ON and “masks” the other functions. This means that the other functions, e.g. staircase time or “pumping up”, continue to run in the background but do not initiate a reaction. After the end of permanent ON, the switching state that would result without the permanent ON function becomes active.

The following parameters appear at *switching ON and OFF delay*:

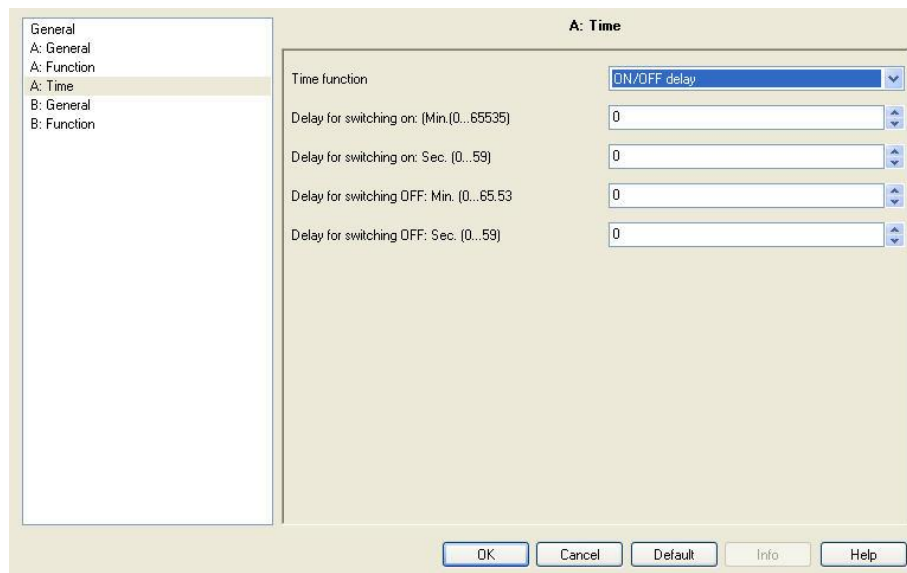

The output can be switched on or off with a delay via this function. Explanations for the on and off delay can be found at [ON and OFF delay](#), page 181. Also, a timing diagram and the effects of different ON and OFF telegrams in combination with ON and OFF delays can be found there.

Delay for switching on: Min. [0...65,535]

Delay for switching on: Sec. [0...59]

Options: 0...65,535
 0...59

Here you set the time by which an ON telegram is delayed after switch on.

Delay for switching OFF: Min. [0...65,535]

Delay for switching OFF: Sec. [0...59]

Options: 0...65,535
 0...59

Here you set the time by which switch OFF is delayed after a switch OFF telegram.

The following parameter appears with the selection *Flashing*:

The screenshot shows a software window titled "A: Time" with a left-hand navigation pane and a main configuration area. The navigation pane lists "General", "A: General", "A: Function", "A: Time" (highlighted), "B: General", and "B: Function". The main area is titled "A: Time" and contains the following parameters:

- Time function: Flashing (selected in a dropdown menu)
- Flashing if object "Switching" is: always flashing, ON (1) or OFF (0) (selected in a dropdown menu)
- Time for ON: Min. (0...65.535): 0 (input field)
- Time for ON: Sec. (1...59): 5 (input field)
- Time for OFF: Min. (0...65.535): 0 (input field)
- Time for OFF: Sec. (1...59): 5 (input field)
- Number of ON-impulses: (1...100): 5 (input field)
- Contact position after flashing: calculate present contact position (selected in a dropdown menu)
- Note: Observe contact life and switching frequency per minute: see technical data (text field)

At the bottom of the window are buttons for "OK", "Cancel", "Default", "Info", and "Help".

The output starts to flash as soon as the parameterized value is received in the communication object *Switch*. The flashing period can be adjusted via the parameterized time duration for ON or OFF. At the start of the flashing period, the output is switched on with a normally open contact and off with a normally closed contact. When a new value is received on the communication object *Switch*, the flashing period will recommence.

The relay state after flashing can be programmed.

Flashing can be inverted when the output is used as a normally closed contact.

The communication object *Status switch* indicates the current relay state during flashing.

Note

Only a certain number of switching actions are possible per minute and Switch Actuator. With frequent switching, a switching delay can occur, as only a certain number of switching actions are possible per minute, see [Technical data](#), from page 7. The same applies directly after bus voltage recovery.

When the function *Flashing* is selected, the service life of the switching contacts must be considered, see [Technical data](#), from page 7.

With a telegram to the communication object *Disable time function*, the function *Flashing* can be disabled. The parameterization is undertaken in parameter window [A: Function](#), page 65, with the parameter *Value object "Disable Time Function" after bus voltage recovery*.

Flashing if object "Switching" is

Options: ON (1)
 OFF (0)
 ON (1) or OFF (0)

Here you set the value of the communication object *Switch* at which the output flashes. Flashing is not retriggerable.

- *ON (1)*: Flashing starts when a telegram with the value 1 is received on the communication object *Switch*.
A telegram with the value 0 ends flashing.
- *OFF (0)*: Flashing starts when a telegram with the value 0 is received on the communication object *Switch*.
A telegram with the value 1 ends flashing.
- *ON (1) or OFF (0)*: A telegram with the value 1 or 0 triggers flashing. Suspension of flashing is not possible in this case.

Time for ON: Min. [0...65,535]

Time for ON: Sec. [0...59]

Options: 0...65,535
 1...5...59

This time for ON defines how long the output is switched ON during a flashing period. The smallest value is 1 second.

Note

Only a certain number of switching actions are possible per minute and Switch Actuator. With frequent switching, a switching delay can occur, as only a certain number of switching actions are possible per minute, see [Technical data](#), from page 7. The same applies directly after bus voltage recovery.

Time for OFF: Min. [0...65,535]

Time for OFF: Sec. [0...59]

Options: 0...65,535
 1...5...59

This time for OFF defines how long the output is switched ON during a flashing period. The smallest value is 1 second.

Note

Only a certain number of switching actions are possible per minute and Switch Actuator. With frequent switching, a switching delay can occur, as only a certain number of switching actions are possible per minute, see [Technical data](#), from page 7. The same applies directly after bus voltage recovery.

Number of ON-impulses: (1...100)Options: 1...5...100

This parameter defines the maximum number of flash pulses. This is useful to avoid unnecessary wear of the contacts caused by flashing.

Contact position after flashing

This parameter defines the state that the parameter should assume after flashing.

- *ON*: The output is switched on after flashing.
- *OFF*: The output is switched off after flashing.
- *calculate present contact position*: The output assumes the switching state, which it had before flashing commenced.

For further information see: [Function chart](#), page 177

Note: Observe contact life and switching frequency per minute**Note**

Only a certain number of switching actions are possible per minute and Switch Actuator. With frequent switching, a switching delay can occur, as only a certain number of switching actions are possible per minute, see [Technical data](#), from page 7. The same applies directly after bus voltage recovery.

3.2.3.1.2 Parameter window A: Preset

In this parameter window, preset settings can be made.

This parameter is visible if in parameter window [A: Function](#), page 65, the parameter *Function Preset* has been enabled.

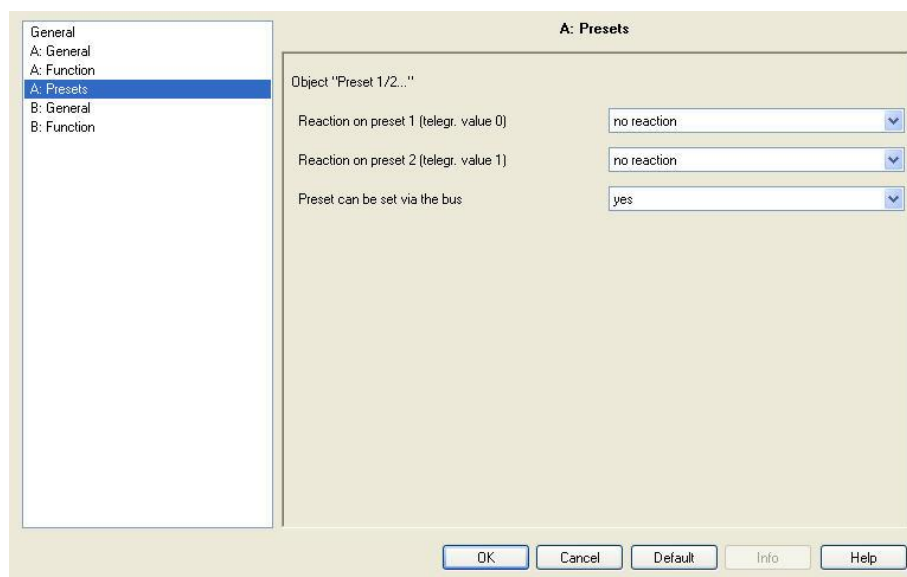

What is a preset?

The presets are used to retrieve a parameterised switch value, e.g. in order to implement light scenes. In addition, the output value that is currently set can be saved as a new preset value.

The preset values can be set (stored) via the bus. In parameter window *A: General* you define whether the values set in the ETS are transferred in a download to the Switch Actuator. The values saved in the actuator are overwritten in this way.

Two presets are available per output. Preset 1 is sent by a telegram with the value 1, Preset 2 is sent with a telegram with the value 0. Separate communication objects are available for recalling and for saving / setting of a preset.

Preset telegrams continue to be executed with the parameterised function *Staircase lighting*. The function *Staircase lighting* is triggered by a preset recall (ON telegram).

Reaction on preset 1 (telegr. value 0)

Options: no reaction
 ON
 OFF
 restore old value before preset 2
 restore parameterized value of preset 2

This parameter determines the contact position that the output assumes when Preset 1 is recalled, i.e., communication object *Recall Preset 1/2* receives a telegram with the value 0.

The following functions can be selected as further selection options:

- *no reaction*: No switching action is undertaken with a preset recall. The preset is ignored. The preset is also ignored with storage via the bus, i.e., no value is saved, the preset remains inactive.
- *restore old value before preset 2*: The current switching state of the relay is stored with the initial call of preset 2. This stored value (switch state) is retained until it is again set by the recall of preset 1. The current switching state is stored with the renewed call of preset 2.

Example

With preset 2, the lighting in a conference room is recalled for a presentation. When the presentation is finished, the lighting is restored via preset 1 to the state it was in previously.

- *restore parameterized value of preset 2*: Preset 2 is reset to the parameterised value. This can be advisable if preset 2 can be stored via the bus, see below.

Note

With the parameterization *restore old value before preset 2* or *restore parameterized value of preset 2*, saving of the preset concerned has no effect. The saved value is not recalled, but rather the parameterised function is undertaken.

Reaction on preset 2 (telegr. value 1)

Options: no reaction
 ON
 OFF

This parameter determines the contact position that the output assumes when Preset 2 is recalled, i.e. communication object *Recall Preset 1/2* receives a telegram with the value 1.

At the same time with the first call of preset 2, the state of the output is saved, so that the corresponding parameterization of the value before preset 2 can be restored.

Preset can be set via the bus

Options: no
 yes

This parameter enables the communication object *Set preset 1/2*. It is thus possible to store the current contact position as the new preset value.

Telegram value 0 saves preset 1, whereas telegram value 1 saves preset 2.

If in parameter *Reaction on preset 1 (telegr. value 0)* the option *no reaction, restore old value before preset 2* or *restore parameterized value of preset 2* has been selected, no new communication object value is saved.

With the parameter *Overwrite scene, preset and threshold value 1 with download* in parameter window *A: General* it is possible that the preset values set via the bus with a download cannot be overwritten and must be protected.

The following preset values are lost with a mains voltage failure. They are overwritten by the parameterised default values.

3.2.3.1.3 Parameter window A: Scene

In this parameter window, all settings for the function *Scene* are undertaken. This parameter is visible if in parameter window [A: Function](#), page 65, the parameter *Function Scene* has been enabled.

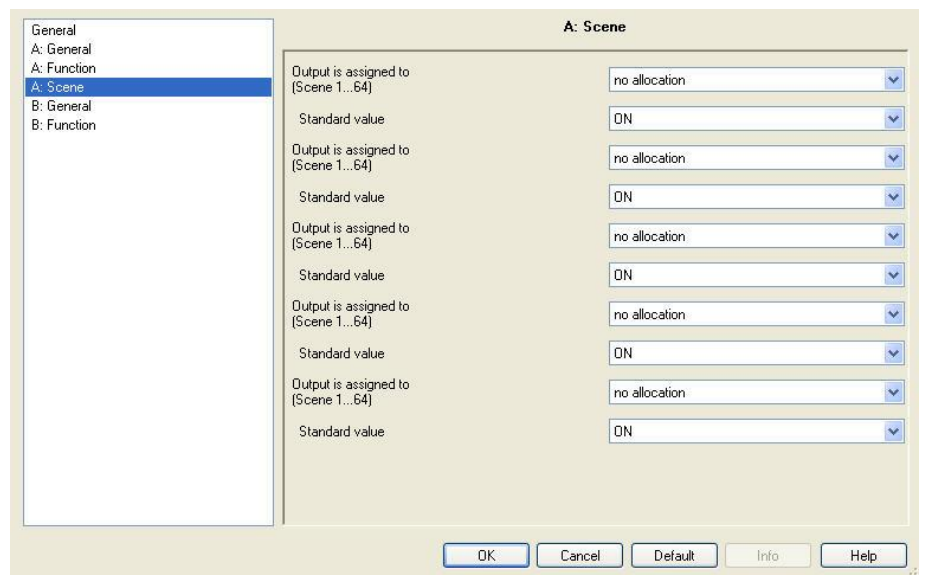

With the parameter *Overwrite scene, preset and threshold value 1 with download* in parameter window *A: General*, it is possible that the scene values set via the bus with a download cannot be overwritten and must be protected.

Output assigned to (Scene 1...64)

Options: no allocation
 Scene 1
 ...
 Scene 64

With the function *Scene*, up to 64 different scenes are managed via a single group address. With this group address, all slaves who are integrated into a scene, are linked via a 1 byte communication object. The following information is contained in a telegram:

- Number of the scene (1...64) as well as
- Telegram: *Call scene* or *Save scene*.

The output can be integrated in up to five scenes. So for example, the scene can be switched on in the morning and switched off in the evening, or the output can be integrated into light scenes.

Standard value

Options: ON
OFF

By storing a scene, the user has the opportunity to change the programmed value stored in the ETS. After a bus voltage failure, the value saved via the KNX is retained.

Note

When a scene is called:
- the function *Time* is restarted.
- the *logical connections* are re-evaluated.

For further information see: *Communication objects* [Output A](#), page 105, [Function Scene](#), page 187 and [Scene code table \(8 bit\)](#), page 201.

3.2.3.1.4 Parameter window A: Logic

In this parameter window, all settings for the function *Logic* are undertaken. This parameter is visible if in parameter window [A: Function](#), page 65, the parameter *Function Logic* has been enabled.

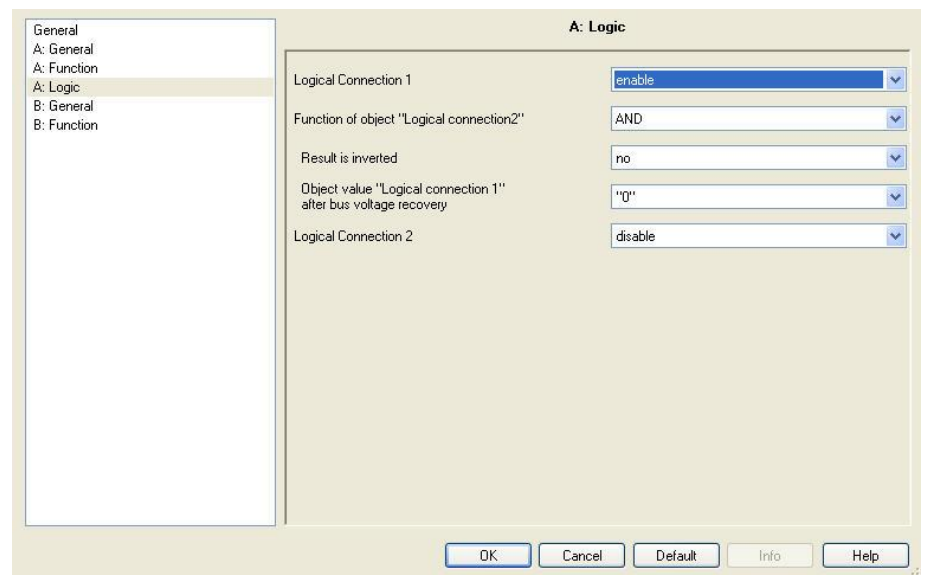

The function *Enable function “logic”* provides up to two logic objects for each output, which can be logically linked with the *Switch* communication object.

The logic is always re-calculated when an object value is received. Hereby, the communication object *Logical connection 1* is first of all evaluated with the communication object *Switch*. The result is then logically linked with the communication object *Logical connection 2*.

Explanations of the logic function can be found at [Function Connection/Logic](#), page 183. Please also observe the [Function chart](#), page 177, where the priorities become evident.

Logical connection 1 active

Options: inactive
 active

With these parameters, the communication object *Logical connection 1* is enabled.

- *active*: The following parameters appear:

Function of object "Logical connection 1"

Options: AND
 OR
 XOR
 GATE

The logical function of the communication object *Logical connection 1* is defined with the switch telegram.

All three standard operations (AND, OR, XOR) are possible. Furthermore, the GATE operation can be used to inhibit switch commands.

For further information see: [Function Connection/Logic](#), page 183

Result is inverted

Options: no
 yes

- *yes*: The result of the logical connection can be inverted.
- *no*: There is no inversion.

Object value "Logical connection 1" after bus voltage recovery

Options: 1
 0

This parameter defines the value allocated to the communication object *Logical connection 1* with bus voltage recovery.

Note

The values of the communication objects *Logical connection 1/2* are stored at bus voltage failure. The values are restored at bus voltage recovery.

At a reset via the bus, the values of the communication objects *Logical connection 1/2* remain unchanged.

A further parameter appears if GATE is selected with the parameter *Function of logical connection*:

**Gate disabled, if object value
"Logical connection 1" is**

Options: 1
 0

This parameter defines the value, at which the communication object *Logical connection 1* disables the GATE.

Disabling of the gate means that the telegrams received on the *Switch* communication object are ignored. As long as the GATE is activated, the value that was sent last to the input of the GATE remains on the output. After a GATE is blocked, the value that was on the output before the block remains on the output of the GATE.

After the GATE is enabled, this value will be retained until a new value is received.

For further information see: [Function chart](#), page 177

The GATE is disabled after bus voltage failure and remains deactivated even after bus voltage recovery.

Logical connection 2 active

The same programming options exist as those for parameter *Logical connection 1 active*.

3.2.3.1.5 Parameter window A: Safety

In this parameter window, all settings for the function *Safety* are undertaken.

This parameter is visible if in parameter window [A: Function](#), page 65, the parameter *Function Safety* has been enabled.

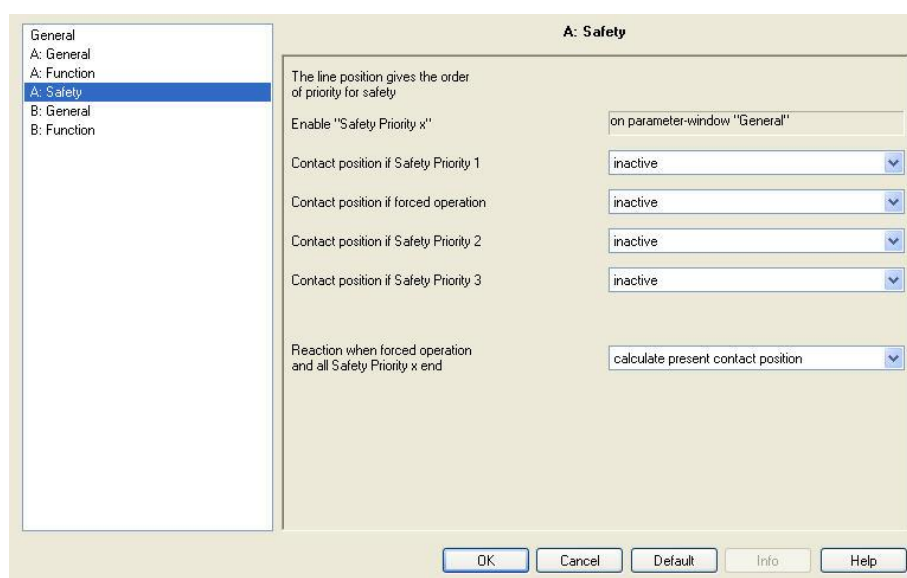

The forced operation (a 1 bit or 2 bit communication object per output) or safety priority (three independent 1 bit communication objects per Switch Actuator) sets the output in a defined state which can no longer be changed as long as forced operation or safety priority is active. The parameterised reaction on bus voltage failure and recovery has a higher priority.

The isolation of the three communication objects *Safety Priority x* ($x = 1, 2, 3$) is undertaken in parameter window *General*. In this window, the monitoring time and the telegram value to be monitored are set. If a telegram is not received within this monitoring time, the output will assume the safety position. The determination is implemented in the parameter window *A: Safety*, which will be described in the following.

As a direct contrast to the three safety priorities, an independent communication object *Forced Positioning* is available for each output.

The forced positioning can be activated or deactivated via a 1 bit or 2 bit communication object. Using the 2 bit communication object, the output state is defined directly via the value.

The switch state after the end of function *Safety* can be set using the parameter *Reaction when forced operation and all Safety Priority x end*.

If multiple demands occur, the priority is defined in accordance with the sequence in parameter window *A: Safety*:

- Safety priority 1 (highest priority)
- Forced operation
- Safety priority 2
- Safety priority 3 (lowest priority)

With the option inactive, the *Safety priority x* or the *Forced positioning* and the respective communication object are not considered and omitted in the priority sequence.

Contact position if Safety Priority 1

Options: unchanged
 inactive
 ON
 OFF

This parameter determines the switch position of the output if the safety condition *Safety Priority 1* (setting undertaken in parameter window [General](#), page 56) has been fulfilled.

The 1 bit communication object *Safety Priority 1* is used as a master for the safety position. The switch positions ON, OFF and unchanged are available.

- *inactive*: The state of the communication objects *Safety Priority 1* has no effect on the output.

Contact position if forced operation

Options: inactive
 unchanged via 1 bit object
 on, via 1 bit object
 off, via 1 bit object
 switch position via 2 bit object

The forced operation relates to the communication object 1 bit or 2 bit *Forced positioning* of the output that is available to every output.

- *inactive*: The state of the communication object *Forced Positioning* has no effect on the output.
- *unchanged via 1 bit object, on, via 1 bit object and off, via 1 bit object*: The 1 bit communication object *Forced positioning* determines the switching state of the output during forced operation.
- *switch position via 2 bit object*: The 2 bit *Forced positioning* communication object is enabled. The value of the telegram sent via the 2 bit communication object determines the switch position, see the following table:

Value	Bit 1	Bit 0	State	Description
0	0	0	Free	If the communication object <i>Forced positioning</i> receives a telegram with the value 0 (binary 00) or 1 (binary 01), the output is enabled and can be actuated via different communication objects.
1	0	1	Free	
2	1	0	Forced OFF	<p>If the communication object <i>Forced positioning</i> receives a telegram with the value 2 (binary 10), the output of the Switch Actuator is forced OFF and remains disabled until forced operation is again switched off.</p> <p>Actuation via another communication object is not possible as long as the forced operation is activated.</p> <p>The state of the output at the end of forced operation can be programmed.</p>
3	1	1	Forced ON	<p>If the communication object <i>Forced positioning</i> receives a telegram with the value 3 (binary 11), the output of the Switch Actuator is switched on and remains disabled until forced operation is again switched off.</p> <p>Actuation via another communication object is not possible as long as the forced operation is activated.</p> <p>The state of the output at the end of forced operation can be programmed.</p>

Object value "Forced positioning on bus voltage recovery"

This parameter is only visible if a forced operation is activated.

Depending on whether the forced operation object is a 1 bit or 2 bit communication object, there are two different parameterization possibilities available:

1 bit communication object:

Options: inactive
active

- *inactive*: Forced operation is switched off, and the output behaves in the same way as with parameter *Contact position when forced operation and all safety priority x end*.
- *active*: Forced operation is active again after bus voltage recovery. The switch position of the output is determined by the programming of *Contact position if forced operation*.

2 bit communication object:

Options: "0" inactive
 "2" OFF
 "3" ON

- *"0" inactive* Forced operation is switched off, and the output behaves in the same way as with parameter *Contact position when forced operation and all safety priority x end*.
- *"2" OFF* The communication object *Forced Positioning* is written with the value 2, and the output is switched off.
- *"3" ON* The communication object *Forced Positioning* is written with the value 3, and the output is switched on.

Contact position if Safety Priority 2 Contact position if Safety Priority 3

The same programming options exist as those for parameter *Contact position if Safety Priority 1*.

Reaction when forced operation and all Safety Priority x end

Options: calculate present contact position
 ON
 OFF
 unchanged

This parameter is only visible if the forced operation or a function *Safety Priority x* ($x = 1, 2$ or 3) is activated.

The contact position of the relay at the end of the forced operation is defined here.

- *calculate present contact position*: After forced operation has ended, the switch value is recalculated and immediately initiated, i.e. the output continues to operate normally in the background during forced operation, the output is not changed and only set after the end of safety priorities.
- *unchanged*: The contact position is retained during forced operation or safety priority. The contact position only changes when a new calculated switch value is received.

3.2.3.1.6 Parameter window A: *Threshold value*

In this parameter window, all settings for the function *Threshold* are undertaken.

This parameter is visible if in parameter window [A: Function](#), page 65, the parameter function *Threshold* has been enabled.

The function *Threshold* enables the evaluation of the 1 byte or 2 byte communication object *Threshold input*. As soon as the value of the communication object falls below or exceeds a threshold value, a switching operation can be triggered. Two independent threshold values are available. Threshold 1 can be modified via the bus.

For further information see: [Function Threshold](#), page 190.

With activated function *Threshold*, the Switch Actuator continues to receive switch telegrams. In this way, the contact position determined by the function *Threshold* can be changed, see [Function chart](#), page 177. The function *Threshold* generates a switch telegram as soon as a new threshold telegram is received, and at the same time a new switch condition is present that overshoots or undershoots the switch criteria.

Data type of object "Threshold input"

Options: 1 byte [0...255]
 2 byte [0...65,635]

The data type for the threshold input that is received via the communication object *Threshold input* can be determined here.

It is possible to choose between a 1 byte integer value and a 2 byte counter value.

Change Threshold 1 over bus

Options: no
 yes

This parameter defines whether threshold value 1 can or cannot be modified via the bus.

- *yes*: Communication object *Threshold value 1* can be changed via the bus. This can be a 1 byte or 2 byte communication object depending on the parameterization of the threshold value input.
- *no*: The communication object *Threshold value 1* can not be changed via the bus.

With the parameter *Overwrite scene, preset and threshold value 1 with download* in parameter window *A: General* it is possible that the threshold values set via the bus with a download cannot be overwritten and must be protected.

Threshold value 1 (0...255)

The value range is dependent on the selection in the parameter *Data type of object "Threshold input"*.

1 byte (0...255):

Options: 0...80...255

2 byte (0...65,535):

Options: 0...20,000...65,535

Threshold value 2 (0...255)

The value range is dependent on the selection in the parameter *Data type of object "Threshold input"*.

1 byte (0...255):

Options: 0...160...255

2 byte (0...65,535):

Options: 0...40,000...65,535

Threshold values define hysteresis

Options: no
 yes

This parameter defines whether *Threshold values 1 and 2* should be interpreted as hysteresis limits.

The hysteresis can reduce continuous threshold value messages if the input value fluctuates around one of the threshold values.

For further information see: [Function threshold](#), page 190

With option *yes*, the following parameters appear:

Behaviour**Falling below lower threshold****Exceeding upper threshold**

Options: unchanged
 ON
 OFF

This parameter determines the switch state of the output in dependence on the value of the communication object, if the value of the communication object *Threshold input* of the upper or lower threshold value is overshoot or undershot.

A reaction only occurs if the communication object value was previously smaller or larger than Threshold 1 or Threshold 2.

For further information see: [Function threshold](#), page 190

With option *no*, the following parameters appear:

Object value < lower threshold**Lower thrsh. <= object <= upper thrsh.****Object value > lower threshold**

Options: unchanged
 ON
 OFF

This parameter determines the switch state of the output (ON, OFF, unchanged) in dependence on the threshold value (the value of the communication object).

**Object "threshold input" value
on bus voltage recovery (0...255)****Object "threshold input" value
on bus voltage recovery (0...65,535)**

The value range is dependent on the selection in the parameter *Data type of object "Threshold input"*.

1 byte (0...255):

Options: 0...255

2 byte (0...65,535):

Options: 0...65,535

This parameter determines the value of the communication object *Threshold input* after bus voltage recovery.

The threshold value evaluation is carried out after bus voltage recovery using the Threshold parameterised here, whereby the last *Status Threshold* detected in operation is used for comparison. Should no *Status Threshold* exist before bus voltage failure, the factory set status (hysteresis limit undershoot) is assumed.

3.2.3.1.7 Parameter window A: Current Detection

In this parameter window, all settings for the function *Current Detection* are undertaken.

This parameter is visible if in parameter window [A: Function](#), page 65, the parameter *Enable function "current detection"* has been enabled.

Note

The function current detection and the respective parameter window are only visible with the Switch Actuators with current detection (SA/S x.16.6.1). They are both equally available in the *Switch Actuator* and *Heating Actuator* modes.

The screenshot shows the 'A: Current Detection' parameter window. The left sidebar contains a tree view with the following items: General, A: General, A: Function, A: Current Detection (highlighted), B: General, and B: Function. The main area of the window is titled 'A: Current Detection' and contains the following settings:

- Datapoint type object "Current Value" (0...65,535 in mA): 2 byte counter (DPT 7.012)
- Send current value, transmission time (0...65,535s, 0 = not send): 0
- Send current value on change of value: no
- Enable current threshold value(s): no
- Only for sinusoidal current the current value is the rms value: see technical data

At the bottom of the window are buttons for OK, Cancel, Default, Info, and Help.

The settings in the parameter window *A: Current Detection* determine if and how the load current of the output is evaluated. With activated current detection, the communication object *Current Value* is enabled.

Using the communication object *Current Value* the detected current value is transferred as a mA value on the KNX. The current value is a sine wave converter to an RMS value.

For further information see: [Current detection specifications](#), page 37 and [Current detection](#), page 171

Datapoint type object "Current Value"
(0...65,535 in mA)

Options: 2 byte counter (DTP 7.012)
 4 byte float (DTP 14.019)

This parameter determines the data type (datapoint, DTP) of the communication object *Current Value*. A 2 byte counter (EIS 10, DPT 7.012, 1 mA per digit) or a 4 byte float value (EIS 9, DTP 14.019) can be selected.

Note

The current detection range is designed for currents between 20 mA and 20 A.

Send current value, transmission time
(0...65,535s, 0 = not send)

Options: 0
 1...65,535

This parameter determines if and at which intervals the present value of current is sent via the communication object *Current Value*. The cycle time must be entered in seconds.

- 0: No current values are sent cyclically via the bus.
The present current values are however continuously available in the communication object *Current Value* of the output and can be read out.

Send current value on change of value

Options: no
 25/50/100/200/500 mA
 1/2/5 A

This parameter determines that with a load change the current value is sent via the communication object *Current Value* on the bus. A current value is always sent on the bus if the current change is greater than the current value set in this parameter. The current value sent on the bus only applies as a new reference value.

- no: No current value is sent.

The smaller the set current value, the more precisely the sent current value will correspond with the actual current value. With a highly fluctuating current value, a high bus load may occur.

For further information see: [Current detection specifications](#), page 37

If the parameter *Send current value, transmission time (0...65,535s, 0 = not send)* is also activated, the counter is reset and restarted after sending the current value.

Note

If for example, a current change of 1 A has been selected, a current value is only sent if the load current exceeds 1 A when starting, for example, from 0 A. This means that no current value is sent (displayed) when a current of 0.9 A flows.

The other way around, a current value can be displayed (sent) even though no current flows. Starting from 1.5 A the current is reduced to 0 A. A current value of 0.5 A is sent on the bus. As for a current value of 0 A, a current value change of 1 A cannot re-occur, no new value is sent on the bus. The last sent and displayed value is 0.5 A.

These inaccuracies can be prevented by additional activation of the parameter *Send current value, transmission time (0...65,535s, 0 = not send)* or if a sufficiently small current change has been selected.

The screenshot shows the 'A: Current Detection' configuration window. On the left is a tree view with the following structure:

- General
 - A: General
 - A: Function
 - A: Current Detection
 - B: General
 - B: Function

The main configuration area contains the following parameters:

- Datapoint type object "Current Value" (0...65,535 in mA): 2 byte counter (DPT 7.012)
- Send current value, transmission time (0...65,535s, 0 = not send): 0
- Send current value on change of value: no
- Enable current threshold value(s): yes
- Evaluation: only with closed contact
- Evaluation delay (0...255s) after contact closing: 3
- Scaling Current-Threshold in: 100mA
- Current threshold 1 in mA (scaled in 10mA or 100mA): 3
- Value of hysteresis current threshold 1: 50mA
- Current threshold 1 +/- hysteresis: send "1" at crossing over
- Enable current threshold 2: no
- Only for sinusoidal current the current value is the rms value: see technical data

Buttons at the bottom: OK, Cancel, Default, Info, Help.

Enable current threshold value(s)

Options: no
yes

Up to two current thresholds for detected currents can be enabled.

- *no*: No current threshold values can be enabled.
- *yes*: First of all, a current threshold value with the respective parameterization option and the communication object *Status Current-Threshold 1* are enabled.

The following parameters appear:

Evaluation

Options: always
only with a closed contact
only with an opened contact

This parameter determines the contact position at which the information *Threshold undershoot* or *Threshold overshoot* is sent.

- *always*: An overshoot or undershoot of the set current threshold is detected at every contact position. This is only sent on the KNX should the status change. As a result, by a contact opened via the KNX (current flow interrupted), a current threshold undershoot (as error) is always detected. This is however only sent with a status change.

- *only with a closed contact:* An undershoot or overshoot of the set current threshold is only evaluated when the contact is closed. As a result, by a contact opened via the KNX (current flow interrupted), a current threshold undershoot (as error) is never detected. Precondition for the correct evaluation is that the contact is closed via a switch action via the KNX. Manual switching is not recognised, the current threshold is not interrupted. Thus manual switching is interpreted as a circuit-breaker or load fault. The evaluation occurs in accordance with the time set in parameter *Evaluation delay* (0...255s) after contact closing.
- *only with an opened contact:* An undershoot or overshoot of the set current threshold is only evaluated when the contact is opened. In this way, for example, you can immediately detect when a switched off contact is inadmissibly switched on manually. Evaluation occurs about one second after opening the contact. The time is fixed for system reasons and cannot be influenced. The monitoring occurs not just once after a contact change, but rather continuously (about once a second).

How does evaluation function?

The detection of the current value occurs in accordance with the parameterised contact position. Should a different contact position than parameterised be the case on the output of the SA/S, the current value is not detected and not evaluated. Furthermore, the current value is also not recorded during the parameterised evaluation delay, whereby a comparison with the setpoint is also not undertaken during this period. After completion of the evaluation delay, the present current value is recorded and compared with the current threshold. The status of the current threshold is only sent if there is a change in the status in comparison to the previous status value.

When *only with a closed contact* is selected, the current is only detected with a closed contact, compared to the current threshold and sent on a change. When the contact is open, there is no current detection and thus no evaluation. A prerequisite is that the contact is opened by a switching telegram initiated via the KNX. Manual switching will not be detected.

In this case, the SA/S assumes that there is an open circuit or a fault on the load. The current detection continues; the detected current value is compared to the current threshold and sent on a status change.

If the value dropped below the threshold before the contact was opened and is still below the threshold after renewed closing of the contact, the *below threshold value* information is not sent again as the status has not changed.

With the option *always*, the current is detected independently of the contact position and continuously compared with the current threshold. The status of the threshold value is only sent when the status has changed.

Example

The SA/S contact is closed and the connected load fails. The undershoot of the current threshold is detected, and the changed status is sent. The contact of the SA/S is subsequently opened.

The current flow is zero and still under the threshold. As the status of the current threshold has not changed, this will not be resent.

The new status is sent only after the next setpoint overshoot.

Evaluation delay (0...255s) after contact closing

Options: 0...3...255

With this parameter, you can ensure that brief start-up currents or current peaks caused by the switching process do not lead to an unwanted current threshold signal.

This method masks out measured values.

After this time has timed-out, only then will the current threshold status be sent via the communication object *Status Current-Threshold* if it has changed.

- 0: The current threshold values are evaluated immediately after contact change.

Scaling Current-Threshold in

Options: 10 mA
100 mA

With this parameter, the current threshold values grid is set. These specifications apply for *Current-Threshold 1* and *Current-Threshold 2*.

Current threshold 1 in mA (scaled in 10 mA or 100 mA)

Options: 0...3...240

With this parameter, a current threshold can be entered in 10 or 100 mA steps.

In dependence on the parameter *Scaling Current-Threshold in*, a threshold range of 0...2.4 A or 0...24 A results.

Value of hysteresis current threshold 1

Options: 3/25/50/100/200/500 mA
1/2/5 A

In order to avoid a continuous change of the threshold value state, the thresholds for current recognition feature a hysteresis function. The set *Value of hysteresis current threshold* ensures that a current

change is only registered as a current change if it is greater than the hysteresis value. Only then will a change of status be sent.

Due to fluctuations in the electrical system and the detection accuracy of the current transformer in the Switch Actuator, a hysteresis of less than 3 mA is not possible.

For further information see: [Function threshold with current detection, page 171](#) and [Current detection specifications, page 37](#)

Note
No hysteresis is used with the option none. With a highly fluctuating current value, this can often lead to frequently fluctuating threshold results. The bus load increases unnecessarily with a continuous status change.

Current threshold 2 +/- hysteresis

Options:

- no sending
- send "0" at crossing over
- send "1" at crossing over
- send "1" at crossing lower
- send "0" at crossing lower
- send "0" at crossing over - "1" at crossing lower
- send "1" at crossing over - "0" at crossing lower

This parameter determines the value of the communication object *Status Current-Threshold 1* when undershooting or overshooting the current threshold.

- *no sending*: No telegram is sent when there is a current overshoot or undershoot
- *send "0" at crossing over*: Should current threshold 1 be overshoot, the value 0 is sent via the communication object *Status Current-Threshold 1*. With an overshoot the value 1 is set but no telegram is sent.
- *send "1" at crossing over*: Should current threshold 1 be overshoot, the value 1 is sent via the communication object *Status Current-Threshold 1*. With an overshoot the value 0 is set but no telegram is sent.
- *send "0" at crossing lower*: Should current threshold 1 be undershot, the value 0 is sent via the communication object *Status Current-Threshold 1*. With an undershoot the value 1 is set but no telegram is sent.

- *send "1" at crossing lower*: Should current threshold 1 be undershot, the value 1 is sent via the communication object *Status Current-Threshold 1*. With an undershoot the value 0 is set but no telegram is sent.
- *send "0" at crossing over - "1" at crossing lower*: Should current threshold 1 be overshoot, the value 0 is sent via the communication object *Status Current-Threshold 1*; with an undershoot the value 1.
- *send "1" at crossing over - "0" at crossing lower*: Should current threshold 1 be overshoot, the value 1 is sent via the communication object *Status Current-Threshold 1*; with an undershoot the value 0.

The sending of the status occurs after the evaluation delay at the earliest and only when the status has changed.

Enable current threshold 2

Options: no
 yes

With this parameter, the second current threshold and the respective communication object *Status Current-Threshold 2* are enabled. For *Status Current-Threshold 2*, the same evaluation delay and scaling and the same evaluation properties as for Threshold 1 apply.

- *yes*: The following parameter appears:

**Current threshold 2 in mA
(scaled in 10 mA or 100 mA)**

Value of hysteresis current threshold 2

Current threshold 2 +/- hysteresis

The setting options of this parameter do not differentiate from the current threshold 1. The descriptions of the parameters can be found further above in this chapter.

Enable "Safety Priority x"

See product manual for further instructions

3.2.4 Communication objects mode *Switch Actuator*

3.2.4.1 Communication objects *General*

No.	Function	Object name	Data type	Flags
0	In Operation	System	EIS 1, 1 bit DPT 1.002	C, T
<p>In order to regularly monitor the presence of the Switch Actuator on the ABB i-bus[®], a monitoring telegram can be sent cyclically on the bus. This communication object is always enabled.</p> <p>Telegram value: 1= system operational 0 = send inactive</p>				
1	Safety Priority 1	General	EIS 1, 1 bit DPT 1.005	C, W, U
<p>This communication object is enabled if in parameter window <i>General</i> the parameter <i>Function Safety Priority 1</i> is selected with the option <i>enabled by object value "0"</i> or <i>enabled by object value "1"</i>.</p> <p>The Switch Actuator can receive a 1 bit telegram via this communication object, which another KNX device, e.g. diagnostics module or wind sensor, sends cyclically. On receipt of the telegram, the communication capability of the bus or the sensor (signalling device) can be monitored. If the Switch Actuator does not receive a telegram (value can be programmed) on the communication object <i>Safety Priority 1</i>, a fault is assumed, and a response programmed in parameter window <i>A: Safety</i> is implemented. The output of the Switch Actuator goes into a safety state and does not process any telegrams. Only after the communication object <i>Safety Priority 1</i> again receives a 1 or 0 (depending on the parameterization) will incoming telegrams be processed again and the contact setting changed.</p> <p>The control period can be adjusted in the parameter <i>General</i> via the parameter <i>Control period in seconds</i>.</p> <p>The safety priority 1 is also triggered if a telegram with the programmable trigger value is received.</p> <p>The function <i>Safety Priority 1</i> has, with the exception of the behaviour at bus voltage failure and recovery, the highest priority in the Switch Actuator, (see Function chart, page 177).</p>				

No.	Function	Object name	Data type	Flags
2	Safety Priority 2	General	EIS 1, 1 bit DPT 1.005	C, W, U
See communication object 1				
3	Safety Priority 3	General	EIS 1, 1 bit DPT 1.005	C, W, U
See communication object 1				
4... 9				
Not assigned.				

3.2.4.2 Communication objects *Output A*

Note

In this product manual, all the current 2/4/8 and 12-fold Switch Actuators are described. These devices each have 2/4/8 or 12 outputs. However, as the functions for all outputs are identical, only the functions of output A will be described.

Should the details in the product manual refer to all outputs, 2-fold corresponds to outputs A...B, 4-fold corresponds to outputs A...D, 8-fold corresponds to outputs A...H and 12-fold corresponds to outputs A...L, the designation outputs A...X is used.

The variants with current detection feature an additional parameter page as well as additional communication objects for this function.

The descriptions of the parameter setting options of Outputs A...X are described from parameter window [A: General](#), page 60.

No.	Function	Object name	Data type	Flags
10	Switch	Output A	EIS 1, 1 bit DPT 1.001	C, W
<p>This communication object is used for switching of the output ON/OFF. The device receives a switch telegram via the switch object.</p> <p>Normally open: Telegram value 1 = switch ON 0 = switch OFF</p> <p>Normally closed contact: Telegram value 1 = switch OFF 0 = switch ON</p> <div style="border: 1px solid black; padding: 5px; margin: 10px 0;"> <p>Note</p> <p>With logical connections or forced operations, a modification of the <i>Switch</i> communication object does not necessarily lead to a change of the contact position.</p> <p><i>For further information see: Function chart, page 177</i></p> </div>				
11	Permanent ON	Output A	EIS 1, 1 bit DPT 1.001	C, W
<p>This communication object is enabled if in parameter window <i>A: Function</i> the parameter <i>Enable function time</i> has been selected with the option <i>yes</i>.</p> <p>With this communication object, the output can be forcibly switched on.</p> <p>If the communication object is assigned with the value 1, the output is switched on irrespective of the value of the object <i>Switch</i> and remains switched on until the communication object <i>Permanent ON</i> has the value 0. After ending the permanent ON state, the state of the communication object <i>Switch</i> is used.</p> <p><i>Permanent ON</i> only switches ON and “masks” the other functions. This means that the other functions, e.g. staircase lighting, continue to run in the background but do not initiate a switching action. After the end of <i>permanent ON</i>, the switching state that would result without the permanent ON function becomes active. The behaviour for the function staircase lighting after <i>Permanent ON</i> is programmed in parameter window A: Time, page 70.</p> <p>This communication object can be used for example to allow the service or maintenance and cleaning personnel to initiate a permanent ON. The device receives a switch telegram via the switch object.</p> <p><i>Permanent On</i> becomes inactive after a download or bus voltage recovery.</p> <p>Telegram value 1 = activates permanent ON mode 0 = deactivates permanent ON mode</p>				

No.	Function	Object name	Data type	Flags
12	Disable time function	Output A	EIS 1, 1 bit DPT 1.003	C, W
<p>This communication object is enabled if in parameter window <i>A: Function</i> the parameter <i>Enable function time</i> has been selected with the option <i>yes</i>.</p> <p>After bus voltage recovery, in the parameter window <i>A: Function</i> the communication object value with the parameter <i>Value object "Disable Time Function"</i> on bus voltage recovery can be determined, for example see: Function time, page 178.</p> <p>With the blocked function <i>Time</i>, the output can only be switched on or off, <i>Enable time functions "delay, staircase lighting, flashing"</i> is not triggered.</p> <p>- Telegram value 1 = Disable function time 0 = Function time enabled</p> <p>The contact position at the time of disabling and enabling is retained and will only be changed with the next switch telegram to the communication object <i>Switch</i>.</p>				
13	Duration of staircase lighting	Output A	EIS 10, 2 byte DPT 7.005	C, R, W
<p>This communication object is enabled if in parameter window <i>A: Time</i> the parameter <i>Duration of staircase lighting can be changed by object</i> has been selected with the option <i>yes</i>.</p> <p>The duration of staircase lighting is set here. The time is defined in seconds.</p> <p>After bus voltage recovery, the value of the communication object is set by the programmed value and the value set via the bus is overwritten.</p>				
14	Warning stair lighting	Output A	EIS 1, 1 bit DPT 1.005	C, T
<p>This communication object is enabled if in parameter window <i>A: Time</i> the function <i>staircase light</i> and in parameter <i>Warning before end of staircase lighting</i> the option <i>via object</i> or <i>via object and switching ON/OFF</i> have been selected.</p>				
15	Call preset 1/2	Output A	EIS 1, 1 bit DPT 1.022	C, W
<p>This communication object is enabled if in parameter window <i>A: Function</i> the parameter <i>Enable function "presets"</i> has been selected with the option <i>yes</i>.</p> <p>Via this communication object, a stored switch state is recalled.</p> <p>It is possible with the corresponding parameterization through a recall of Preset 1/2 to restore the switching state before the recall of Preset 2 or to reset the switching state to the parameterised value before Preset 2.</p> <p>Telegram value 0 = The parameterised value (switch state) of Preset 1 is recalled. 1 = The parameterised value (switch state) of Preset 2 is recalled.</p> <p>For further information see: Function Preset, page 185</p>				

No.	Function	Object name	Data type	Flags
18	Logical connection 1	Output A	1 bit (EIS 1) DPT 1.002	C, W
<p>This communication object is enabled if in parameter window <i>A: Function</i> the parameter <i>Enable function "logic"</i> has been selected with the option <i>yes</i>.</p> <p>Using this communication object, the output of the first of two logic objects can be assigned. The logical connection is defined in the parameter window <i>A: Logic</i>.</p> <p>Initially, the switch object is then logically linked with the communication object <i>Logical connection 1</i>. The result of this is then logically linked with the communication object <i>Logical connection 2</i>.</p> <div style="border: 1px solid black; padding: 5px; margin: 10px 0;"> <p>Note</p> <p>The values of the communication objects <i>Logical connection 1/2</i> are stored at bus voltage failure. The values are restored at bus voltage recovery.</p> <p>If values of the communication objects <i>Logical connection 1/2</i> were not assigned, they will be deactivated.</p> <p>At a reset via the bus, the values of the communication objects <i>Logical connection 1/2</i> remain unchanged.</p> </div> <p>For further information see: Function Connection/Logic, page 183</p>				
19	Logical connection 2	Output A	1 bit (EIS 1) DPT 1.002	C, W
See communication object 18.				
20	Forced Positioning	Output A	1 bit (EIS 1) DPT 1.003	C, W
<p>This communication object is enabled if in parameter window <i>A: Function</i> the parameter <i>Enable functions "priority and safety operation"</i> has been selected with the option <i>yes</i> and the parameter <i>Contact position if forced operation</i> has been selected with a <i>1 bit object</i>.</p> <p>If the object receives the value 1, the output is forcibly set to the parameterised switch position, which has been set in the parameter window <i>A: Safety</i>.</p> <p>The forced positioning of the contact should remain until forced operation is ended. This is then the case when a 0 is received via the communication object <i>Forced operation</i>.</p> <p>Please note that the function <i>Security priority 1</i> and a bus failure have a higher priority on the switching state, see Function chart, page 177.</p>				

No.	Function	Object name	Data type	Flags
20	Forced Positioning	Output A	2 bit (EIS 8) DPT 2.001	C, W
<p>This communication object is enabled if in parameter window <i>A: Function</i> the parameter <i>Enable functions "priority and safety operation"</i> has been selected with the option <i>yes</i> and the parameter <i>Contact position if forced operation</i> has been selected with a <i>2 bit object</i>.</p> <p>Output X can be forcibly operated via this communication object (e.g. by a higher-level control). The value of the communication object directly defines the forced position of the contact:</p> <ul style="list-style-type: none"> 0 or 1 = The output is not forcibly operated. 2 = The output is forcibly switched off 3 = The output is forcibly switched on <p>At the end of the forced operation, a check is performed to see if one of the three functions <i>Safety Priority x</i> (x = 2 and 3) is active. If necessary, the contact position is set by the active safety priorities. If no function <i>Safety Priority x</i> is active, the contact is set as parameterized in parameter window <i>A: Safety</i> in parameter <i>Reaction when forced operation and all Safety Priority x end</i>.</p> <p>Please note that the function <i>Security priority 1</i> and a bus failure have a higher priority on the switching state, see Function chart, page 177.</p>				
21	Threshold input	Output A	1 byte (EIS 6) 2 byte (EIS 10) DPT 5.010 DPT 7.001	C, W
<p>This communication object is enabled if in parameter window <i>A: Function</i> the parameter <i>Enable function "threshold"</i> has been selected with the option <i>yes</i>.</p> <p>Depending on the selection in parameter window <i>A: Threshold</i>, a 1 byte (integer value) or 2 byte communication object (counter) is enabled.</p> <p>If in the parameter window <i>A: Threshold</i> the parameterised threshold is overshot, a switching action can be performed.</p>				
22	Change Threshold value 1	Output A	1 byte (EIS 6) 2 byte (EIS 10) DPT 5.010 DPT 7.001	C, W
<p>This communication object is enabled if in parameter window <i>A: Threshold</i> the parameter <i>Change Threshold 1 over bus</i> has been selected with the option <i>yes</i>.</p> <p>Depending on the selection in parameter window <i>A: Threshold</i>, a 1 byte (integer value) or 2 byte communication object (counter) is enabled.</p> <p>If the communication object <i>Change Threshold value 1</i> is enabled, the threshold can be changed via the bus.</p>				
23...				
24				
Not assigned.				

No.	Function	Object name	Data type	Flags
25	Contact monitoring	Output A	EIS 1, 1 bit DPT 1.002	C, R, T
<p>This communication object is enabled if in parameter window A: <i>Function</i> the parameter <i>Enable function "current detection"</i> has been selected with the option yes.</p> <p>The communication object value shows the contact state when the contact is open.</p> <p>Should a current flow be detected with an opening of the contact initiated via the KNX, contact welding or manual switch on has occurred (contact fault).</p> <p>The evaluation of whether a current flows occurs about one second after a contact is opened. The current is safely detected should a measurable current (about 20 mA) flow.</p> <p>A prerequisite for correct evaluation is switching via the KNX.</p> <p>Telegram value 1 = contact error 0 = no current flows</p>				
26	Current Value	Output A	EIS10, 2 byte DPT 7.012	C, R, T
<p>This communication object is enabled if in parameter window A: <i>Function</i> the parameter <i>Enable function "current detection"</i> has been selected with the option yes and in the parameter window A: <i>Current Detection</i> of the 2 byte data type.</p> <p>The presently detected current is sent on the KNX. 1 digit corresponds to 1 mA.</p> <p>For further information see: Current detection specifications, page 37</p>				
26	Current Value	Output A	EIS 9, 4 byte DPT 14.019	C, R, T
<p>This communication object is enabled if in parameter window A: <i>Function</i> the parameter <i>Enable function "current detection"</i> has been selected with the option yes and in the parameter window A: <i>Current Detection</i> of the 4 byte data type.</p> <p>The current value is transferred as a mA value on the KNX.</p> <p>For further information see: Current detection specifications, page 37</p>				
27	Status Current-Threshold 1	Output A	EIS 1, 1 bit DPT 1.002	C, R, T
<p>This communication object is enabled if in parameter window A: <i>Current Detection</i> the parameter <i>Enable current threshold value(s)</i> has been selected with the option yes.</p> <p>The status of the current threshold 1 is only sent when a change occurs.</p> <p>The status value can be inverted.</p> <p>Telegram value 1 = threshold 1 plus threshold 1 hysteresis is exceeded 0 = threshold 1 minus threshold 1 hysteresis is exceeded</p> <p>For further information see: Function threshold with current detection, page 171</p>				

No.	Function	Object name	Data type	Flags
18	Logical connection 1	Output A	1 bit (EIS 1) DPT 1.002	C, W
<p>This communication object is enabled if in parameter window <i>A: Function</i> the parameter <i>Enable function "logic"</i> has been selected with the option <i>yes</i>.</p> <p>Using this communication object, the output of the first of two logic objects can be assigned. The logical connection is defined in the parameter window <i>A: Logic</i>.</p> <p>Initially, the switch object is then logically linked with the communication object <i>Logical connection 1</i>. The result of this is then logically linked with the communication object <i>Logical connection 2</i>.</p> <div style="border: 1px solid black; padding: 5px; margin: 10px 0;"> <p>Note</p> <p>The values of the communication objects <i>Logical connection 1/2</i> are stored at bus voltage failure. The values are restored at bus voltage recovery.</p> <p>If values of the communication objects <i>Logical connection 1/2</i> were not assigned, they will be deactivated.</p> <p>At a reset via the bus, the values of the communication objects <i>Logical connection 1/2</i> remain unchanged.</p> </div> <p>For further information see: Function Connection/Logic, page 183</p>				
19	Logical connection 2	Output A	1 bit (EIS 1) DPT 1.002	C, W
<p>See communication object 18.</p>				
20	Forced Positioning	Output A	1 bit (EIS 1) DPT 1.003	C, W
<p>This communication object is enabled if in parameter window <i>A: Function</i> the parameter <i>Enable functions "priority and safety operation"</i> has been selected with the option <i>yes</i> and the parameter <i>Contact position if forced operation</i> has been selected with a <i>1 bit object</i>.</p> <p>If the object receives the value 1, the output is forcibly set to the parameterised switch position, which has been set in the parameter window <i>A: Safety</i>.</p> <p>The forced positioning of the contact should remain until forced operation is ended. This is then the case when a 0 is received via the communication object <i>Forced operation</i>.</p> <p>Please note that the function <i>Security priority 1</i> and a bus failure have a higher priority on the switching state, see Function chart, page 177.</p>				

No.	Function	Object name	Data type	Flags
20	Forced Positioning	Output A	2 bit (EIS 8) DPT 2.001	C, W
<p>This communication object is enabled if in parameter window <i>A: Function</i> the parameter <i>Enable functions "priority and safety operation"</i> has been selected with the option <i>yes</i> and the parameter <i>Contact position if forced operation</i> has been selected with a <i>2 bit object</i>.</p> <p>Output X can be forcibly operated via this communication object (e.g. by a higher-level control). The value of the communication object directly defines the forced position of the contact:</p> <ul style="list-style-type: none"> 0 or 1 = The output is not forcibly operated. 2 = The output is forcibly switched off 3 = The output is forcibly switched on <p>At the end of the forced operation, a check is performed to see if one of the three functions <i>Safety Priority x</i> ($x = 2$ and 3) is active. If necessary, the contact position is set by the active safety priorities. If no function <i>Safety Priority x</i> is active, the contact is set as parameterized in parameter window <i>A: Safety</i> in parameter <i>Reaction when forced operation and all Safety Priority x end</i>.</p> <p>Please note that the function <i>Security priority 1</i> and a bus failure have a higher priority on the switching state, see Function chart, page 177.</p>				
21	Threshold input	Output A	1 byte (EIS 6) 2 byte (EIS 10) DPT 5.010 DPT 7.001	C, W
<p>This communication object is enabled if in parameter window <i>A: Function</i> the parameter <i>Enable function "threshold"</i> has been selected with the option <i>yes</i>.</p> <p>Depending on the selection in parameter window <i>A: Threshold</i>, a 1 byte (integer value) or 2 byte communication object (counter) is enabled.</p> <p>If in the parameter window <i>A: Threshold</i> the parameterised threshold is overshot, a switching action can be performed.</p>				
22	Change Threshold value 1	Output A	1 byte (EIS 6) 2 byte (EIS 10) DPT 5.010 DPT 7.001	C, W
<p>This communication object is enabled if in parameter window <i>A: Threshold</i> the parameter <i>Change Threshold 1 over bus</i> has been selected with the option <i>yes</i>.</p> <p>Depending on the selection in parameter window <i>A: Threshold</i>, a 1 byte (integer value) or 2 byte communication object (counter) is enabled.</p> <p>If the communication object <i>Change Threshold value 1</i> is enabled, the threshold can be changed via the bus.</p>				
23...				
24				
Not assigned.				

No.	Function	Object name	Data type	Flags
25	Contact monitoring	Output A	EIS 1, 1 bit DPT 1.002	C, R, T
<p>This communication object is enabled if in parameter window <i>A: Function</i> the parameter <i>Enable function "current detection"</i> has been selected with the option <i>yes</i>.</p> <p>The communication object value shows the contact state when the contact is open.</p> <p>Should a current flow be detected with an opening of the contact initiated via the KNX, contact welding or manual switch on has occurred (contact fault).</p> <p>The evaluation of whether a current flows occurs about one second after a contact is opened. The current is safely detected should a measurable current (about 20 mA) flow.</p> <p>A prerequisite for correct evaluation is switching via the KNX.</p> <p>Telegram value 1 = contact error 0 = no current flows</p>				
26	Current Value	Output A	EIS10, 2 byte DPT 7.012	C, R, T
<p>This communication object is enabled if in parameter window <i>A: Function</i> the parameter <i>Enable function "current detection"</i> has been selected with the option <i>yes</i> and in the parameter window <i>A: Current Detection</i> of the 2 byte data type.</p> <p>The presently detected current is sent on the KNX. 1 digit corresponds to 1 mA.</p> <p>For further information see: Current detection specifications, page 37</p>				
26	Current Value	Output A	EIS 9, 4 byte DPT 14.019	C, R, T
<p>This communication object is enabled if in parameter window <i>A: Function</i> the parameter <i>Enable function "current detection"</i> has been selected with the option <i>yes</i> and in the parameter window <i>A: Current Detection</i> of the 4 byte data type.</p> <p>The current value is transferred as a mA value on the KNX.</p> <p>For further information see: Current detection specifications, page 37</p>				
27	Status Current-Threshold 1	Output A	EIS 1, 1 bit DPT 1.002	C, R, T
<p>This communication object is enabled if in parameter window <i>A: Current Detection</i> the parameter <i>Enable current threshold value(s)</i> has been selected with the option <i>yes</i>.</p> <p>The status of the current threshold 1 is only sent when a change occurs.</p> <p>The status value can be inverted.</p> <p>Telegram value 1 = threshold 1 plus threshold 1 hysteresis is exceeded 0 = threshold 1 minus threshold 1 hysteresis is exceeded</p> <p>For further information see: Function threshold with current detection, page 171</p>				

No.	Function	Object name	Data type	Flags
18	Logical connection 1	Output A	1 bit (EIS 1) DPT 1.002	C, W
<p>This communication object is enabled if in parameter window <i>A: Function</i> the parameter <i>Enable function "logic"</i> has been selected with the option <i>yes</i>.</p> <p>Using this communication object, the output of the first of two logic objects can be assigned. The logical connection is defined in the parameter window <i>A: Logic</i>.</p> <p>Initially, the switch object is then logically linked with the communication object <i>Logical connection 1</i>. The result of this is then logically linked with the communication object <i>Logical connection 2</i>.</p> <div style="border: 1px solid black; padding: 5px; margin: 10px 0;"> <p>Note</p> <p>The values of the communication objects <i>Logical connection 1/2</i> are stored at bus voltage failure. The values are restored at bus voltage recovery.</p> <p>If values of the communication objects <i>Logical connection 1/2</i> were not assigned, they will be deactivated.</p> <p>At a reset via the bus, the values of the communication objects <i>Logical connection 1/2</i> remain unchanged.</p> </div> <p>For further information see: Function Connection/Logic, page 183</p>				
19	Logical connection 2	Output A	1 bit (EIS 1) DPT 1.002	C, W
See communication object 18.				
20	Forced Positioning	Output A	1 bit (EIS 1) DPT 1.003	C, W
<p>This communication object is enabled if in parameter window <i>A: Function</i> the parameter <i>Enable functions "priority and safety operation"</i> has been selected with the option <i>yes</i> and the parameter <i>Contact position if forced operation</i> has been selected with a <i>1 bit object</i>.</p> <p>If the object receives the value 1, the output is forcibly set to the parameterised switch position, which has been set in the parameter window <i>A: Safety</i>.</p> <p>The forced positioning of the contact should remain until forced operation is ended. This is then the case when a 0 is received via the communication object <i>Forced operation</i>.</p> <p>Please note that the function <i>Security priority 1</i> and a bus failure have a higher priority on the switching state, see Function chart, page 177.</p>				

No.	Function	Object name	Data type	Flags
20	Forced Positioning	Output A	2 bit (EIS 8) DPT 2.001	C, W
<p>This communication object is enabled if in parameter window <i>A: Function</i> the parameter <i>Enable functions "priority and safety operation"</i> has been selected with the option <i>yes</i> and the parameter <i>Contact position if forced operation</i> has been selected with a <i>2 bit object</i>.</p> <p>Output X can be forcibly operated via this communication object (e.g. by a higher-level control). The value of the communication object directly defines the forced position of the contact:</p> <ul style="list-style-type: none"> 0 or 1 = The output is not forcibly operated. 2 = The output is forcibly switched off 3 = The output is forcibly switched on <p>At the end of the forced operation, a check is performed to see if one of the three functions <i>Safety Priority x</i> (x = 2 and 3) is active. If necessary, the contact position is set by the active safety priorities. If no function <i>Safety Priority x</i> is active, the contact is set as parameterized in parameter window <i>A: Safety</i> in parameter <i>Reaction when forced operation and all Safety Priority x end</i>.</p> <p>Please note that the function <i>Security priority 1</i> and a bus failure have a higher priority on the switching state, see Function chart, page 177.</p>				
21	Threshold input	Output A	1 byte (EIS 6) 2 byte (EIS 10) DPT 5.010 DPT 7.001	C, W
<p>This communication object is enabled if in parameter window <i>A: Function</i> the parameter <i>Enable function "threshold"</i> has been selected with the option <i>yes</i>.</p> <p>Depending on the selection in parameter window <i>A: Threshold</i>, a 1 byte (integer value) or 2 byte communication object (counter) is enabled.</p> <p>If in the parameter window <i>A: Threshold</i> the parameterised threshold is overshot, a switching action can be performed.</p>				
22	Change Threshold value 1	Output A	1 byte (EIS 6) 2 byte (EIS 10) DPT 5.010 DPT 7.001	C, W
<p>This communication object is enabled if in parameter window <i>A: Threshold</i> the parameter <i>Change Threshold 1 over bus</i> has been selected with the option <i>yes</i>.</p> <p>Depending on the selection in parameter window <i>A: Threshold</i>, a 1 byte (integer value) or 2 byte communication object (counter) is enabled.</p> <p>If the communication object <i>Change Threshold value 1</i> is enabled, the threshold can be changed via the bus.</p>				
23... 24				
Not assigned.				

No.	Function	Object name	Data type	Flags
25	Contact monitoring	Output A	EIS 1, 1 bit DPT 1.002	C, R, T
<p>This communication object is enabled if in parameter window A: <i>Function</i> the parameter <i>Enable function "current detection"</i> has been selected with the option yes.</p> <p>The communication object value shows the contact state when the contact is open.</p> <p>Should a current flow be detected with an opening of the contact initiated via the KNX, contact welding or manual switch on has occurred (contact fault).</p> <p>The evaluation of whether a current flows occurs about one second after a contact is opened. The current is safely detected should a measurable current (about 20 mA) flow.</p> <p>A prerequisite for correct evaluation is switching via the KNX.</p> <p>Telegram value 1 = contact error 0 = no current flows</p>				
26	Current Value	Output A	EIS10, 2 byte DPT 7.012	C, R, T
<p>This communication object is enabled if in parameter window A: <i>Function</i> the parameter <i>Enable function "current detection"</i> has been selected with the option yes and in the parameter window A: <i>Current Detection</i> of the 2 byte data type.</p> <p>The presently detected current is sent on the KNX. 1 digit corresponds to 1 mA.</p> <p>For further information see: Current detection specifications, page 37</p>				
26	Current Value	Output A	EIS 9, 4 byte DPT 14.019	C, R, T
<p>This communication object is enabled if in parameter window A: <i>Function</i> the parameter <i>Enable function "current detection"</i> has been selected with the option yes and in the parameter window A: <i>Current Detection</i> of the 4 byte data type.</p> <p>The current value is transferred as a mA value on the KNX.</p> <p>For further information see: Current detection specifications, page 37</p>				
27	Status Current-Threshold 1	Output A	EIS 1, 1 bit DPT 1.002	C, R, T
<p>This communication object is enabled if in parameter window A: <i>Current Detection</i> the parameter <i>Enable current threshold value(s)</i> has been selected with the option yes.</p> <p>The status of the current threshold 1 is only sent when a change occurs.</p> <p>The status value can be inverted.</p> <p>Telegram value 1 = threshold 1 plus threshold 1 hysteresis is exceeded 0 = threshold 1 minus threshold 1 hysteresis is exceeded</p> <p>For further information see: Function threshold with current detection, page 171</p>				

No.	Function	Object name	Data type	Flags
18	Logical connection 1	Output A	1 bit (EIS 1) DPT 1.002	C, W
<p>This communication object is enabled if in parameter window <i>A: Function</i> the parameter <i>Enable function "logic"</i> has been selected with the option <i>yes</i>.</p> <p>Using this communication object, the output of the first of two logic objects can be assigned. The logical connection is defined in the parameter window <i>A: Logic</i>.</p> <p>Initially, the switch object is then logically linked with the communication object <i>Logical connection 1</i>. The result of this is then logically linked with the communication object <i>Logical connection 2</i>.</p> <div style="border: 1px solid black; padding: 5px; margin: 10px 0;"> <p>Note</p> <p>The values of the communication objects <i>Logical connection 1/2</i> are stored at bus voltage failure. The values are restored at bus voltage recovery.</p> <p>If values of the communication objects <i>Logical connection 1/2</i> were not assigned, they will be deactivated.</p> <p>At a reset via the bus, the values of the communication objects <i>Logical connection 1/2</i> remain unchanged.</p> </div> <p>For further information see: Function Connection/Logic, page 183</p>				
19	Logical connection 2	Output A	1 bit (EIS 1) DPT 1.002	C, W
<p>See communication object 18.</p>				
20	Forced Positioning	Output A	1 bit (EIS 1) DPT 1.003	C, W
<p>This communication object is enabled if in parameter window <i>A: Function</i> the parameter <i>Enable functions "priority and safety operation"</i> has been selected with the option <i>yes</i> and the parameter <i>Contact position if forced operation</i> has been selected with a <i>1 bit object</i>.</p> <p>If the object receives the value 1, the output is forcibly set to the parameterised switch position, which has been set in the parameter window <i>A: Safety</i>.</p> <p>The forced positioning of the contact should remain until forced operation is ended. This is then the case when a 0 is received via the communication object <i>Forced operation</i>.</p> <p>Please note that the function <i>Security priority 1</i> and a bus failure have a higher priority on the switching state, see Function chart, page 177.</p>				

No.	Function	Object name	Data type	Flags
20	Forced Positioning	Output A	2 bit (EIS 8) DPT 2.001	C, W
<p>This communication object is enabled if in parameter window <i>A: Function</i> the parameter <i>Enable functions "priority and safety operation"</i> has been selected with the option <i>yes</i> and the parameter <i>Contact position if forced operation</i> has been selected with a <i>2 bit object</i>.</p> <p>Output X can be forcibly operated via this communication object (e.g. by a higher-level control). The value of the communication object directly defines the forced position of the contact:</p> <ul style="list-style-type: none"> 0 or 1 = The output is not forcibly operated. 2 = The output is forcibly switched off 3 = The output is forcibly switched on <p>At the end of the forced operation, a check is performed to see if one of the three functions <i>Safety Priority x</i> ($x = 2$ and 3) is active. If necessary, the contact position is set by the active safety priorities. If no function <i>Safety Priority x</i> is active, the contact is set as parameterized in parameter window <i>A: Safety</i> in parameter <i>Reaction when forced operation and all Safety Priority x end</i>.</p> <p>Please note that the function <i>Security priority 1</i> and a bus failure have a higher priority on the switching state, see Function chart, page 177.</p>				
21	Threshold input	Output A	1 byte (EIS 6) 2 byte (EIS 10) DPT 5.010 DPT 7.001	C, W
<p>This communication object is enabled if in parameter window <i>A: Function</i> the parameter <i>Enable function "threshold"</i> has been selected with the option <i>yes</i>.</p> <p>Depending on the selection in parameter window <i>A: Threshold</i>, a 1 byte (integer value) or 2 byte communication object (counter) is enabled.</p> <p>If in the parameter window <i>A: Threshold</i> the parameterised threshold is overshot, a switching action can be performed.</p>				
22	Change Threshold value 1	Output A	1 byte (EIS 6) 2 byte (EIS 10) DPT 5.010 DPT 7.001	C, W
<p>This communication object is enabled if in parameter window <i>A: Threshold</i> the parameter <i>Change Threshold 1 over bus</i> has been selected with the option <i>yes</i>.</p> <p>Depending on the selection in parameter window <i>A: Threshold</i>, a 1 byte (integer value) or 2 byte communication object (counter) is enabled.</p> <p>If the communication object <i>Change Threshold value 1</i> is enabled, the threshold can be changed via the bus.</p>				
23...				
24				
Not assigned.				

No.	Function	Object name	Data type	Flags
25	Contact monitoring	Output A	EIS 1, 1 bit DPT 1.002	C, R, T
<p>This communication object is enabled if in parameter window <i>A: Function</i> the parameter <i>Enable function "current detection"</i> has been selected with the option <i>yes</i>.</p> <p>The communication object value shows the contact state when the contact is open.</p> <p>Should a current flow be detected with an opening of the contact initiated via the KNX, contact welding or manual switch on has occurred (contact fault).</p> <p>The evaluation of whether a current flows occurs about one second after a contact is opened. The current is safely detected should a measurable current (about 20 mA) flow.</p> <p>A prerequisite for correct evaluation is switching via the KNX.</p> <p>Telegram value 1 = contact error 0 = no current flows</p>				
26	Current Value	Output A	EIS10, 2 byte DPT 7.012	C, R, T
<p>This communication object is enabled if in parameter window <i>A: Function</i> the parameter <i>Enable function "current detection"</i> has been selected with the option <i>yes</i> and in the parameter window <i>A: Current Detection</i> of the 2 byte data type.</p> <p>The presently detected current is sent on the KNX. 1 digit corresponds to 1 mA.</p> <p>For further information see: Current detection specifications, page 37</p>				
26	Current Value	Output A	EIS 9, 4 byte DPT 14.019	C, R, T
<p>This communication object is enabled if in parameter window <i>A: Function</i> the parameter <i>Enable function "current detection"</i> has been selected with the option <i>yes</i> and in the parameter window <i>A: Current Detection</i> of the 4 byte data type.</p> <p>The current value is transferred as a mA value on the KNX.</p> <p>For further information see: Current detection specifications, page 37</p>				
27	Status Current-Threshold 1	Output A	EIS 1, 1 bit DPT 1.002	C, R, T
<p>This communication object is enabled if in parameter window <i>A: Current Detection</i> the parameter <i>Enable current threshold value(s)</i> has been selected with the option <i>yes</i>.</p> <p>The status of the current threshold 1 is only sent when a change occurs.</p> <p>The status value can be inverted.</p> <p>Telegram value 1 = threshold 1 plus threshold 1 hysteresis is exceeded 0 = threshold 1 minus threshold 1 hysteresis is exceeded</p> <p>For further information see: Function threshold with current detection, page 171</p>				

No.	Function	Object name	Data type	Flags
18	Logical connection 1	Output A	1 bit (EIS 1) DPT 1.002	C, W
<p>This communication object is enabled if in parameter window <i>A: Function</i> the parameter <i>Enable function "logic"</i> has been selected with the option <i>yes</i>.</p> <p>Using this communication object, the output of the first of two logic objects can be assigned. The logical connection is defined in the parameter window <i>A: Logic</i>.</p> <p>Initially, the switch object is then logically linked with the communication object <i>Logical connection 1</i>. The result of this is then logically linked with the communication object <i>Logical connection 2</i>.</p> <div style="border: 1px solid black; padding: 5px; margin: 10px 0;"> <p>Note</p> <p>The values of the communication objects <i>Logical connection 1/2</i> are stored at bus voltage failure. The values are restored at bus voltage recovery.</p> <p>If values of the communication objects <i>Logical connection 1/2</i> were not assigned, they will be deactivated.</p> <p>At a reset via the bus, the values of the communication objects <i>Logical connection 1/2</i> remain unchanged.</p> </div> <p>For further information see: Function Connection/Logic, page 183</p>				
19	Logical connection 2	Output A	1 bit (EIS 1) DPT 1.002	C, W
See communication object 18.				
20	Forced Positioning	Output A	1 bit (EIS 1) DPT 1.003	C, W
<p>This communication object is enabled if in parameter window <i>A: Function</i> the parameter <i>Enable functions "priority and safety operation"</i> has been selected with the option <i>yes</i> and the parameter <i>Contact position if forced operation</i> has been selected with a <i>1 bit object</i>.</p> <p>If the object receives the value 1, the output is forcibly set to the parameterised switch position, which has been set in the parameter window <i>A: Safety</i>.</p> <p>The forced positioning of the contact should remain until forced operation is ended. This is then the case when a 0 is received via the communication object <i>Forced operation</i>.</p> <p>Please note that the function <i>Security priority 1</i> and a bus failure have a higher priority on the switching state, see Function chart, page 177.</p>				

No.	Function	Object name	Data type	Flags
20	Forced Positioning	Output A	2 bit (EIS 8) DPT 2.001	C, W
<p>This communication object is enabled if in parameter window <i>A: Function</i> the parameter <i>Enable functions "priority and safety operation"</i> has been selected with the option <i>yes</i> and the parameter <i>Contact position if forced operation</i> has been selected with a <i>2 bit object</i>.</p> <p>Output X can be forcibly operated via this communication object (e.g. by a higher-level control). The value of the communication object directly defines the forced position of the contact:</p> <ul style="list-style-type: none"> 0 or 1 = The output is not forcibly operated. 2 = The output is forcibly switched off 3 = The output is forcibly switched on <p>At the end of the forced operation, a check is performed to see if one of the three functions <i>Safety Priority x</i> (x = 2 and 3) is active. If necessary, the contact position is set by the active safety priorities. If no function <i>Safety Priority x</i> is active, the contact is set as parameterized in parameter window <i>A: Safety</i> in parameter <i>Reaction when forced operation and all Safety Priority x end</i>.</p> <p>Please note that the function <i>Security priority 1</i> and a bus failure have a higher priority on the switching state, see Function chart, page 177.</p>				
21	Threshold input	Output A	1 byte (EIS 6) 2 byte (EIS 10) DPT 5.010 DPT 7.001	C, W
<p>This communication object is enabled if in parameter window <i>A: Function</i> the parameter <i>Enable function "threshold"</i> has been selected with the option <i>yes</i>.</p> <p>Depending on the selection in parameter window <i>A: Threshold</i>, a 1 byte (integer value) or 2 byte communication object (counter) is enabled.</p> <p>If in the parameter window <i>A: Threshold</i> the parameterised threshold is overshot, a switching action can be performed.</p>				
22	Change Threshold value 1	Output A	1 byte (EIS 6) 2 byte (EIS 10) DPT 5.010 DPT 7.001	C, W
<p>This communication object is enabled if in parameter window <i>A: Threshold</i> the parameter <i>Change Threshold 1 over bus</i> has been selected with the option <i>yes</i>.</p> <p>Depending on the selection in parameter window <i>A: Threshold</i>, a 1 byte (integer value) or 2 byte communication object (counter) is enabled.</p> <p>If the communication object <i>Change Threshold value 1</i> is enabled, the threshold can be changed via the bus.</p>				
23...				
24				
Not assigned.				

No.	Function	Object name	Data type	Flags
25	Contact monitoring	Output A	EIS 1, 1 bit DPT 1.002	C, R, T
<p>This communication object is enabled if in parameter window <i>A: Function</i> the parameter <i>Enable function "current detection"</i> has been selected with the option yes.</p> <p>The communication object value shows the contact state when the contact is open.</p> <p>Should a current flow be detected with an opening of the contact initiated via the KNX, contact welding or manual switch on has occurred (contact fault).</p> <p>The evaluation of whether a current flows occurs about one second after a contact is opened. The current is safely detected should a measurable current (about 20 mA) flow.</p> <p>A prerequisite for correct evaluation is switching via the KNX.</p> <p>Telegram value 1 = contact error 0 = no current flows</p>				
26	Current Value	Output A	EIS10, 2 byte DPT 7.012	C, R, T
<p>This communication object is enabled if in parameter window <i>A: Function</i> the parameter <i>Enable function "current detection"</i> has been selected with the option yes and in the parameter window <i>A: Current Detection</i> of the 2 byte data type.</p> <p>The presently detected current is sent on the KNX. 1 digit corresponds to 1 mA.</p> <p>For further information see: Current detection specifications, page 37</p>				
26	Current Value	Output A	EIS 9, 4 byte DPT 14.019	C, R, T
<p>This communication object is enabled if in parameter window <i>A: Function</i> the parameter <i>Enable function "current detection"</i> has been selected with the option yes and in the parameter window <i>A: Current Detection</i> of the 4 byte data type.</p> <p>The current value is transferred as a mA value on the KNX.</p> <p>For further information see: Current detection specifications, page 37</p>				
27	Status Current-Threshold 1	Output A	EIS 1, 1 bit DPT 1.002	C, R, T
<p>This communication object is enabled if in parameter window <i>A: Current Detection</i> the parameter <i>Enable current threshold value(s)</i> has been selected with the option yes.</p> <p>The status of the current threshold 1 is only sent when a change occurs.</p> <p>The status value can be inverted.</p> <p>Telegram value 1 = threshold 1 plus threshold 1 hysteresis is exceeded 0 = threshold 1 minus threshold 1 hysteresis is exceeded</p> <p>For further information see: Function threshold with current detection, page 171</p>				

No.	Function	Object name	Data type	Flags
28	Status Current-Threshold 2	Output A	EIS 1, 1 bit DPT 1.002	C, R, T
<p>This communication object is enabled if in parameter window A: <i>Current Detection</i> the parameter <i>Enable current threshold value(s)</i> and the parameter <i>Enable current threshold 2</i> has been selected with the option <i>yes</i>.</p> <p>The status of the current threshold 1 is only sent when a change occurs.</p> <p>The status value can be inverted.</p> <p>Telegram value 1 = threshold 2 plus threshold 2 hysteresis is exceeded 0 = threshold 2 minus threshold 2 hysteresis is exceeded</p> <p>For further information see: Function threshold with current detection, page 171</p>				
29	Status Switch	Output A	EIS 1, 1 bit DPT 1.001	C, R, T
<p>This communication object is enabled if in parameter window A: <i>General</i> the parameter <i>Status response of switching state Object "Status Switch"</i> or the option <i>always</i> have been selected.</p> <p>The communication object value directly indicates the current contact position of the switching relay.</p> <p>The status value can be inverted.</p> <p>Telegram value 1 = relay ON or OFF depending on the parameterization 0 = relay OFF or ON depending on the parameterization</p>				
10	Switch	Output A	EIS 1, 1 bit DPT 1.001	C, W
<p>This communication object is used for switching of the output ON/OFF.</p> <p>The device receives a switch telegram via the switch object.</p> <p>Normally open:</p> <p>Telegram value 1 = switch ON 0 = switch OFF</p> <p>Normally closed contact:</p> <p>Telegram value 1 = switch OFF 0 = switch ON</p> <div style="border: 1px solid black; padding: 5px; margin-top: 10px;"> <p>Note</p> <p>With logical connections or forced operations, a modification of the <i>Switch</i> communication object does not necessarily lead to a change of the contact position.</p> <p>For further information see: Function chart, page 177</p> </div>				
11	Permanent ON	Output A	EIS 1, 1 bit DPT 1.001	C, W
<p>This communication object is enabled if in parameter window A: <i>Function</i> the parameter <i>Enable function time</i> has been selected with the option <i>yes</i>.</p> <p>With this communication object, the output can be forcibly switched on.</p> <p>If the communication object is assigned with the value 1, the output is switched on irrespective of the value of the object <i>Switch</i> and remains switched on until the communication object <i>Permanent ON</i> has the value 0. After ending the permanent ON state, the state of the</p>				

No.	Function	Object name	Data type	Flags
12	Disable time function	Output A	EIS 1, 1 bit DPT 1.003	C, W
<p>This communication object is enabled if in parameter window <i>A: Function</i> the parameter <i>Enable function time</i> has been selected with the option <i>yes</i>.</p> <p>After bus voltage recovery, in the parameter window <i>A: Function</i> the communication object value with the parameter <i>Value object "Disable Time Function"</i> on bus voltage recovery can be determined, for example see: Function time, page 178.</p> <p>With the blocked function <i>Time</i>, the output can only be switched on or off, <i>Enable time functions "delay, staircase lighting, flashing"</i> is not triggered.</p> <p>- Telegram value 1 = Disable function time 0 = Function time enabled</p> <p>The contact position at the time of disabling and enabling is retained and will only be changed with the next switch telegram to the communication object <i>Switch</i>.</p>				
13	Duration of staircase lighting	Output A	EIS 10, 2 byte DPT 7.005	C, R, W
<p>This communication object is enabled if in parameter window <i>A: Time</i> the parameter <i>Duration of staircase lighting can be changed by object</i> has been selected with the option <i>yes</i>.</p> <p>The duration of staircase lighting is set here. The time is defined in seconds.</p> <p>After bus voltage recovery, the value of the communication object is set by the programmed value and the value set via the bus is overwritten.</p>				
14	Warning stair lighting	Output A	EIS 1, 1 bit DPT 1.005	C, T
<p>This communication object is enabled if in parameter window <i>A: Time</i> the function <i>staircase light</i> and in parameter <i>Warning before end of staircase lighting</i> the option <i>via object</i> or <i>via object and switching ON/OFF</i> have been selected.</p>				
15	Call preset 1/2	Output A	EIS 1, 1 bit DPT 1.022	C, W
<p>This communication object is enabled if in parameter window <i>A: Function</i> the parameter <i>Enable function "presets"</i> has been selected with the option <i>yes</i>.</p> <p>Via this communication object, a stored switch state is recalled.</p> <p>It is possible with the corresponding parameterization through a recall of Preset 1/2 to restore the switching state before the recall of Preset 2 or to reset the switching state to the parameterised value before Preset 2.</p> <p>Telegram value 0 = The parameterised value (switch state) of Preset 1 is recalled. 1 = The parameterised value (switch state) of Preset 2 is recalled.</p> <p>For further information see: Function Preset, page 185</p>				

No.	Function	Object name	Data type	Flags																																			
16	Set preset 1/2	Output A	EIS 1, 1 bit DPT 1.022	C, W																																			
<p>This communication object is enabled if in parameter window A: <i>Function</i> the parameter <i>Enable function "presets"</i> has been selected with the option <i>yes</i>.</p> <p>Using this communication object, the current switching state can be stored as the new preset value.</p> <p>Telegram value 0 = The current switching state is stored as the Preset 1 value. 1 = The current switching state is stored as the Preset 2 value.</p> <p><i>For further information see: Function preset, page 185</i></p>																																							
17	8 bit scene	Output A	1 byte Non EIS DPT 18.001	C, W																																			
<p>This communication object is enabled if in parameter window A: <i>Function</i> the parameter <i>Enable function scene</i> has been selected with the option <i>yes</i>.</p> <p>Using this 8 bit communication object, a scene telegram can be sent using a coded telegram. The telegram contains the number of the respective scene as well as the information if the scene is to be called, or if the current switch state is to be assigned to the scene.</p> <p>Telegram format (1-Byte): MXSSSSSS (MSB) (LSB) M: 0 – scene is called 1 – scene is stored (if allowed) X: not used S: Number of the scene (1-64: 00000000 ... 00111111)</p> <table border="1" data-bbox="604 1339 1369 1758"> <thead> <tr> <th colspan="2">KNX 1 byte telegram value</th> <th rowspan="2">Meaning</th> </tr> <tr> <th>Decimal</th> <th>Hexadecimal</th> </tr> </thead> <tbody> <tr> <td>00 or 64</td> <td>00h or 40h</td> <td>Recall scene 1</td> </tr> <tr> <td>01 or 65</td> <td>01h or 41h</td> <td>Recall scene 2</td> </tr> <tr> <td>02 or 66</td> <td>02h or 42h</td> <td>Recall scene 3</td> </tr> <tr> <td>...</td> <td>...</td> <td>...</td> </tr> <tr> <td>63 or 127</td> <td>3Fh or 7Fh</td> <td>Recall scene 64</td> </tr> <tr> <td>128 or 192</td> <td>80h or B0h</td> <td>Store scene 1</td> </tr> <tr> <td>129 or 193</td> <td>81h or B1h</td> <td>Store scene 2</td> </tr> <tr> <td>130 or 194</td> <td>82h or B2h</td> <td>Store scene 3</td> </tr> <tr> <td>...</td> <td>...</td> <td>...</td> </tr> <tr> <td>191 or 255</td> <td>AFh or FFh</td> <td>Store scene 64</td> </tr> </tbody> </table> <p><i>For further information see: Function Scene, page 187 and Scene code table (8 Bit), page 201</i></p>					KNX 1 byte telegram value		Meaning	Decimal	Hexadecimal	00 or 64	00h or 40h	Recall scene 1	01 or 65	01h or 41h	Recall scene 2	02 or 66	02h or 42h	Recall scene 3	63 or 127	3Fh or 7Fh	Recall scene 64	128 or 192	80h or B0h	Store scene 1	129 or 193	81h or B1h	Store scene 2	130 or 194	82h or B2h	Store scene 3	191 or 255	AFh or FFh	Store scene 64
KNX 1 byte telegram value		Meaning																																					
Decimal	Hexadecimal																																						
00 or 64	00h or 40h	Recall scene 1																																					
01 or 65	01h or 41h	Recall scene 2																																					
02 or 66	02h or 42h	Recall scene 3																																					
...																																					
63 or 127	3Fh or 7Fh	Recall scene 64																																					
128 or 192	80h or B0h	Store scene 1																																					
129 or 193	81h or B1h	Store scene 2																																					
130 or 194	82h or B2h	Store scene 3																																					
...																																					
191 or 255	AFh or FFh	Store scene 64																																					

No.	Function	Object name	Data type	Flags
18	Logical connection 1	Output A	1 bit (EIS 1) DPT 1.002	C, W
<p>This communication object is enabled if in parameter window <i>A: Function</i> the parameter <i>Enable function "logic"</i> has been selected with the option <i>yes</i>.</p> <p>Using this communication object, the output of the first of two logic objects can be assigned. The logical connection is defined in the parameter window <i>A: Logic</i>.</p> <p>Initially, the switch object is then logically linked with the communication object <i>Logical connection 1</i>. The result of this is then logically linked with the communication object <i>Logical connection 2</i>.</p> <div style="border: 1px solid black; padding: 5px; margin: 10px 0;"> <p>Note</p> <p>The values of the communication objects <i>Logical connection 1/2</i> are stored at bus voltage failure. The values are restored at bus voltage recovery.</p> <p>If values of the communication objects <i>Logical connection 1/2</i> were not assigned, they will be deactivated.</p> <p>At a reset via the bus, the values of the communication objects <i>Logical connection 1/2</i> remain unchanged.</p> </div> <p>For further information see: Function Connection/Logic, page 183</p>				
19	Logical connection 2	Output A	1 bit (EIS 1) DPT 1.002	C, W
See communication object 18.				
20	Forced Positioning	Output A	1 bit (EIS 1) DPT 1.003	C, W
<p>This communication object is enabled if in parameter window <i>A: Function</i> the parameter <i>Enable functions "priority and safety operation"</i> has been selected with the option <i>yes</i> and the parameter <i>Contact position if forced operation</i> has been selected with a <i>1 bit object</i>.</p> <p>If the object receives the value 1, the output is forcibly set to the parameterised switch position, which has been set in the parameter window <i>A: Safety</i>.</p> <p>The forced positioning of the contact should remain until forced operation is ended. This is then the case when a 0 is received via the communication object <i>Forced operation</i>.</p> <p>Please note that the function <i>Security priority 1</i> and a bus failure have a higher priority on the switching state, see Function chart, page 177.</p>				

No.	Function	Object name	Data type	Flags
20	Forced Positioning	Output A	2 bit (EIS 8) DPT 2.001	C, W
<p>This communication object is enabled if in parameter window <i>A: Function</i> the parameter <i>Enable functions "priority and safety operation"</i> has been selected with the option <i>yes</i> and the parameter <i>Contact position if forced operation</i> has been selected with a <i>2 bit object</i>.</p> <p>Output X can be forcibly operated via this communication object (e.g. by a higher-level control). The value of the communication object directly defines the forced position of the contact:</p> <ul style="list-style-type: none"> 0 or 1 = The output is not forcibly operated. 2 = The output is forcibly switched off 3 = The output is forcibly switched on <p>At the end of the forced operation, a check is performed to see if one of the three functions <i>Safety Priority x</i> (x = 2 and 3) is active. If necessary, the contact position is set by the active safety priorities. If no function <i>Safety Priority x</i> is active, the contact is set as parameterized in parameter window <i>A: Safety</i> in parameter <i>Reaction when forced operation and all Safety Priority x end</i>.</p> <p>Please note that the function <i>Security priority 1</i> and a bus failure have a higher priority on the switching state, see Function chart, page 177.</p>				
21	Threshold input	Output A	1 byte (EIS 6) 2 byte (EIS 10) DPT 5.010 DPT 7.001	C, W
<p>This communication object is enabled if in parameter window <i>A: Function</i> the parameter <i>Enable function "threshold"</i> has been selected with the option <i>yes</i>.</p> <p>Depending on the selection in parameter window <i>A: Threshold</i>, a 1 byte (integer value) or 2 byte communication object (counter) is enabled.</p> <p>If in the parameter window <i>A: Threshold</i> the parameterised threshold is overshot, a switching action can be performed.</p>				
22	Change Threshold value 1	Output A	1 byte (EIS 6) 2 byte (EIS 10) DPT 5.010 DPT 7.001	C, W
<p>This communication object is enabled if in parameter window <i>A: Threshold</i> the parameter <i>Change Threshold 1 over bus</i> has been selected with the option <i>yes</i>.</p> <p>Depending on the selection in parameter window <i>A: Threshold</i>, a 1 byte (integer value) or 2 byte communication object (counter) is enabled.</p> <p>If the communication object <i>Change Threshold value 1</i> is enabled, the threshold can be changed via the bus.</p>				
23...				
24				
Not assigned.				

No.	Function	Object name	Data type	Flags
25	Contact monitoring	Output A	EIS 1, 1 bit DPT 1.002	C, R, T
<p>This communication object is enabled if in parameter window <i>A: Function</i> the parameter <i>Enable function "current detection"</i> has been selected with the option <i>yes</i>.</p> <p>The communication object value shows the contact state when the contact is open.</p> <p>Should a current flow be detected with an opening of the contact initiated via the KNX, contact welding or manual switch on has occurred (contact fault).</p> <p>The evaluation of whether a current flows occurs about one second after a contact is opened. The current is safely detected should a measurable current (about 20 mA) flow.</p> <p>A prerequisite for correct evaluation is switching via the KNX.</p> <p>Telegram value 1 = contact error 0 = no current flows</p>				
26	Current Value	Output A	EIS10, 2 byte DPT 7.012	C, R, T
<p>This communication object is enabled if in parameter window <i>A: Function</i> the parameter <i>Enable function "current detection"</i> has been selected with the option <i>yes</i> and in the parameter window <i>A: Current Detection</i> of the 2 byte data type.</p> <p>The presently detected current is sent on the KNX. 1 digit corresponds to 1 mA.</p> <p>For further information see: Current detection specifications, page 37</p>				
26	Current Value	Output A	EIS 9, 4 byte DPT 14.019	C, R, T
<p>This communication object is enabled if in parameter window <i>A: Function</i> the parameter <i>Enable function "current detection"</i> has been selected with the option <i>yes</i> and in the parameter window <i>A: Current Detection</i> of the 4 byte data type.</p> <p>The current value is transferred as a mA value on the KNX.</p> <p>For further information see: Current detection specifications, page 37</p>				
27	Status Current-Threshold 1	Output A	EIS 1, 1 bit DPT 1.002	C, R, T
<p>This communication object is enabled if in parameter window <i>A: Current Detection</i> the parameter <i>Enable current threshold value(s)</i> has been selected with the option <i>yes</i>.</p> <p>The status of the current threshold 1 is only sent when a change occurs.</p> <p>The status value can be inverted.</p> <p>Telegram value 1 = threshold 1 plus threshold 1 hysteresis is exceeded 0 = threshold 1 minus threshold 1 hysteresis is exceeded</p> <p>For further information see: Function threshold with current detection, page 171</p>				

No.	Function	Function	Object	Object name	Data type	Data type	Flags	Flags
10	Switch	Status Current-Threshold	Output	Output A	EIS 1, 1 bit DPT 1.002	EIS 1, 1 bit DPT 1.002	C, W	C, R, T
<p>This communication object is enabled if in parameter window A: <i>Current Detection</i> the parameter <i>Enable current threshold 2</i> has been selected with the option <i>yes</i>. Normally open.</p> <p>Telegram value 1 = switch ON 0 = switch OFF</p> <p>The status value can be inverted.</p> <p>Normally closed contact: Telegram value 1 = switch OFF threshold 2 plus threshold 2 hysteresis is exceeded 0 = switch ON threshold 2 minus threshold 2 hysteresis exceeded</p>								
Note							page 171	
29	Status Switch	Status Switch	Output A	Output A	EIS 1, 1 bit DPT 1.001	EIS 1, 1 bit DPT 1.001	C, W	C, R, T
<p>With logical connections or forced operations, a modification of the Switch communication object does not necessarily lead to a change of the contact position.</p> <p>For further information see: Function chart page 177</p> <p>This communication object is enabled if in parameter window A: <i>General</i> the parameter <i>Status response of switching state</i> Object "Status Switch" or the option <i>always</i> have been selected.</p>								
11	Permanent ON	Permanent ON	Output A	Output A	EIS 1, 1 bit DPT 1.001	EIS 1, 1 bit DPT 1.001	C, W	C, W
<p>The communication object value directly indicates the current contact position of the switching relay.</p> <p>The status value can be inverted.</p> <p>This communication object is enabled if in parameter window A: <i>Function</i> the parameter <i>Enable function time</i> has been selected with the option <i>yes</i>. 0 = relay OFF or ON depending on the parameterization 1 = relay ON or OFF depending on the parameterization</p> <p>With this communication object, the output can be forcibly switched on.</p> <p>If the communication object is assigned with the value 1, the output is switched on irrespective of the value of the object <i>Switch</i> and remains switched on until the communication object <i>Permanent ON</i> has the value 0. After ending the permanent ON state, the state of the communication object <i>Switch</i> is used.</p> <p><i>Permanent ON</i> only switches ON and "masks" the other functions. This means that the other functions, e.g. staircase lighting, continue to run in the background but do not initiate a switching action. After the end of <i>permanent ON</i>, the switching state that would result without the permanent ON function becomes active. The behaviour for the function staircase lighting after <i>Permanent ON</i> is programmed in parameter window A: Time, page 70.</p> <p>This communication object can be used for example to allow the service or maintenance and cleaning personnel to initiate a permanent ON. The device receives a switch telegram via the switch object.</p> <p><i>Permanent On</i> becomes inactive after a download or bus voltage recovery.</p> <p>Telegram value 1 = activates permanent ON mode 0 = deactivates permanent ON mode</p>								

No.	Function	Object name	Data type	Flags
12	Disable time function	Output A	EIS 1, 1 bit DPT 1.003	C, W
<p>This communication object is enabled if in parameter window <i>A: Function</i> the parameter <i>Enable function time</i> has been selected with the option <i>yes</i>.</p> <p>After bus voltage recovery, in the parameter window <i>A: Function</i> the communication object value with the parameter <i>Value object "Disable Time Function"</i> on bus voltage recovery can be determined, for example see: Function time, page 178.</p> <p>With the blocked function <i>Time</i>, the output can only be switched on or off, <i>Enable time functions "delay, staircase lighting, flashing"</i> is not triggered.</p> <p>- Telegram value 1 = Disable function time 0 = Function time enabled</p> <p>The contact position at the time of disabling and enabling is retained and will only be changed with the next switch telegram to the communication object <i>Switch</i>.</p>				
13	Duration of staircase lighting	Output A	EIS 10, 2 byte DPT 7.005	C, R, W
<p>This communication object is enabled if in parameter window <i>A: Time</i> the parameter <i>Duration of staircase lighting can be changed by object</i> has been selected with the option <i>yes</i>.</p> <p>The duration of staircase lighting is set here. The time is defined in seconds.</p> <p>After bus voltage recovery, the value of the communication object is set by the programmed value and the value set via the bus is overwritten.</p>				
14	Warning stair lighting	Output A	EIS 1, 1 bit DPT 1.005	C, T
<p>This communication object is enabled if in parameter window <i>A: Time</i> the function staircase light and in parameter <i>Warning before end of staircase lighting</i> the option <i>via object</i> or <i>via object and switching ON/OFF</i> have been selected.</p>				
15	Call preset 1/2	Output A	EIS 1, 1 bit DPT 1.022	C, W
<p>This communication object is enabled if in parameter window <i>A: Function</i> the parameter <i>Enable function "presets"</i> has been selected with the option <i>yes</i>.</p> <p>Via this communication object, a stored switch state is recalled.</p> <p>It is possible with the corresponding parameterization through a recall of Preset 1/2 to restore the switching state before the recall of Preset 2 or to reset the switching state to the parameterised value before Preset 2.</p> <p>Telegram value 0 = The parameterised value (switch state) of Preset 1 is recalled. 1 = The parameterised value (switch state) of Preset 2 is recalled.</p> <p>For further information see: Function Preset, page 185</p>				

No.	Function	Object name	Data type	Flags
18	Logical connection 1	Output A	1 bit (EIS 1) DPT 1.002	C, W
<p>This communication object is enabled if in parameter window <i>A: Function</i> the parameter <i>Enable function "logic"</i> has been selected with the option <i>yes</i>.</p> <p>Using this communication object, the output of the first of two logic objects can be assigned. The logical connection is defined in the parameter window <i>A: Logic</i>.</p> <p>Initially, the switch object is then logically linked with the communication object <i>Logical connection 1</i>. The result of this is then logically linked with the communication object <i>Logical connection 2</i>.</p> <div style="border: 1px solid black; padding: 5px; margin: 10px 0;"> <p>Note</p> <p>The values of the communication objects <i>Logical connection 1/2</i> are stored at bus voltage failure. The values are restored at bus voltage recovery.</p> <p>If values of the communication objects <i>Logical connection 1/2</i> were not assigned, they will be deactivated.</p> <p>At a reset via the bus, the values of the communication objects <i>Logical connection 1/2</i> remain unchanged.</p> </div> <p>For further information see: Function Connection/Logic, page 183</p>				
19	Logical connection 2	Output A	1 bit (EIS 1) DPT 1.002	C, W
See communication object 18.				
20	Forced Positioning	Output A	1 bit (EIS 1) DPT 1.003	C, W
<p>This communication object is enabled if in parameter window <i>A: Function</i> the parameter <i>Enable functions "priority and safety operation"</i> has been selected with the option <i>yes</i> and the parameter <i>Contact position if forced operation</i> has been selected with a <i>1 bit object</i>.</p> <p>If the object receives the value 1, the output is forcibly set to the parameterised switch position, which has been set in the parameter window <i>A: Safety</i>.</p> <p>The forced positioning of the contact should remain until forced operation is ended. This is then the case when a 0 is received via the communication object <i>Forced operation</i>.</p> <p>Please note that the function <i>Security priority 1</i> and a bus failure have a higher priority on the switching state, see Function chart, page 177.</p>				

No.	Function	Object name	Data type	Flags
20	Forced Positioning	Output A	2 bit (EIS 8) DPT 2.001	C, W
<p>This communication object is enabled if in parameter window <i>A: Function</i> the parameter <i>Enable functions "priority and safety operation"</i> has been selected with the option <i>yes</i> and the parameter <i>Contact position if forced operation</i> has been selected with a <i>2 bit object</i>.</p> <p>Output X can be forcibly operated via this communication object (e.g. by a higher-level control). The value of the communication object directly defines the forced position of the contact:</p> <ul style="list-style-type: none"> 0 or 1 = The output is not forcibly operated. 2 = The output is forcibly switched off 3 = The output is forcibly switched on <p>At the end of the forced operation, a check is performed to see if one of the three functions <i>Safety Priority x</i> (x = 2 and 3) is active. If necessary, the contact position is set by the active safety priorities. If no function <i>Safety Priority x</i> is active, the contact is set as parameterized in parameter window <i>A: Safety</i> in parameter <i>Reaction when forced operation and all Safety Priority x end</i>.</p> <p>Please note that the function <i>Security priority 1</i> and a bus failure have a higher priority on the switching state, see Function chart, page 177.</p>				
21	Threshold input	Output A	1 byte (EIS 6) 2 byte (EIS 10) DPT 5.010 DPT 7.001	C, W
<p>This communication object is enabled if in parameter window <i>A: Function</i> the parameter <i>Enable function "threshold"</i> has been selected with the option <i>yes</i>.</p> <p>Depending on the selection in parameter window <i>A: Threshold</i>, a 1 byte (integer value) or 2 byte communication object (counter) is enabled.</p> <p>If in the parameter window <i>A: Threshold</i> the parameterised threshold is overshot, a switching action can be performed.</p>				
22	Change Threshold value 1	Output A	1 byte (EIS 6) 2 byte (EIS 10) DPT 5.010 DPT 7.001	C, W
<p>This communication object is enabled if in parameter window <i>A: Threshold</i> the parameter <i>Change Threshold 1 over bus</i> has been selected with the option <i>yes</i>.</p> <p>Depending on the selection in parameter window <i>A: Threshold</i>, a 1 byte (integer value) or 2 byte communication object (counter) is enabled.</p> <p>If the communication object <i>Change Threshold value 1</i> is enabled, the threshold can be changed via the bus.</p>				
23...				
24				
Not assigned.				

No.	Function	Object name	Data type	Flags
25	Contact monitoring	Output A	EIS 1, 1 bit DPT 1.002	C, R, T
<p>This communication object is enabled if in parameter window A: <i>Function</i> the parameter <i>Enable function "current detection"</i> has been selected with the option yes.</p> <p>The communication object value shows the contact state when the contact is open.</p> <p>Should a current flow be detected with an opening of the contact initiated via the KNX, contact welding or manual switch on has occurred (contact fault).</p> <p>The evaluation of whether a current flows occurs about one second after a contact is opened. The current is safely detected should a measurable current (about 20 mA) flow.</p> <p>A prerequisite for correct evaluation is switching via the KNX.</p> <p>Telegram value 1 = contact error 0 = no current flows</p>				
26	Current Value	Output A	EIS10, 2 byte DPT 7.012	C, R, T
<p>This communication object is enabled if in parameter window A: <i>Function</i> the parameter <i>Enable function "current detection"</i> has been selected with the option yes and in the parameter window A: <i>Current Detection</i> of the 2 byte data type.</p> <p>The presently detected current is sent on the KNX. 1 digit corresponds to 1 mA.</p> <p>For further information see: Current detection specifications, page 37</p>				
26	Current Value	Output A	EIS 9, 4 byte DPT 14.019	C, R, T
<p>This communication object is enabled if in parameter window A: <i>Function</i> the parameter <i>Enable function "current detection"</i> has been selected with the option yes and in the parameter window A: <i>Current Detection</i> of the 4 byte data type.</p> <p>The current value is transferred as a mA value on the KNX.</p> <p>For further information see: Current detection specifications, page 37</p>				
27	Status Current-Threshold 1	Output A	EIS 1, 1 bit DPT 1.002	C, R, T
<p>This communication object is enabled if in parameter window A: <i>Current Detection</i> the parameter <i>Enable current threshold value(s)</i> has been selected with the option yes.</p> <p>The status of the current threshold 1 is only sent when a change occurs.</p> <p>The status value can be inverted.</p> <p>Telegram value 1 = threshold 1 plus threshold 1 hysteresis is exceeded 0 = threshold 1 minus threshold 1 hysteresis is exceeded</p> <p>For further information see: Function threshold with current detection, page 171</p>				

No.	Function	Object name	Data type	Flags
28	Status Current-Threshold 2	Output A	EIS 1, 1 bit DPT 1.002	C, R, T
<p>This communication object is enabled if in parameter window <i>A: Current Detection</i> the parameter <i>Enable current threshold value(s)</i> and the parameter <i>Enable current threshold 2</i> has been selected with the option <i>yes</i>.</p> <p>The status of the current threshold 1 is only sent when a change occurs.</p> <p>The status value can be inverted.</p> <p>Telegram value 1 = threshold 2 plus threshold 2 hysteresis is exceeded 0 = threshold 2 minus threshold 2 hysteresis is exceeded</p> <p><i>For further information see: Function threshold with current detection, page 171</i></p>				
29	Status Switch	Output A	EIS 1, 1 bit DPT 1.001	C, R, T
<p>This communication object is enabled if in parameter window <i>A: General</i> the parameter <i>Status response of switching state Object "Status Switch"</i> or the option <i>always</i> have been selected.</p> <p>The communication object value directly indicates the current contact position of the switching relay.</p> <p>The status value can be inverted.</p> <p>Telegram value 1 = relay ON or OFF depending on the parameterization 0 = relay OFF or ON depending on the parameterization</p>				

3.2.5 Operating mode *Heating Actuator*

In the operating mode *Heating Actuator*, the Switch Actuators generally are used as setting elements for electro-thermal valve drives. Room temperature can be controlled in conjunction with a room thermostat or room thermometer, which controls the Switch Actuator.

Various types of control are possible, e.g. PWM, 2-point control (1 bit) or continuous control (1 byte).

Every individual output of a Switch Actuator can be controlled via a 1 bit control value. For this purpose, the communication objects *Switch* of the outputs have to be connected with the communication objects *Control value* of the room thermostats/temperature controllers.

Note

The parameter of the room thermostats must be set to *continuous 2-point control* or *switching 2-point control*.

With so-called continuous control, a 1 byte value (0...255) is used as an input signal. This input signal is used in the Switch Actuator in accordance with the programmable cycle time in the ON and OFF command of the switch relay. At 0 %, the valve is closed, and at 100 % it is fully opened. Intermediate values are calculated via pulse width modulation (PWM).

For further information see: [Pulse width modulation – Calculation](#), page 194

Note

Electromechanical Switch Actuators, including SA/S Switch Actuators, have mechanical contacts. On the one hand safe electrical isolation and a very high switching capacity is achieved, on the other hand this is associated with switching noises and mechanical wear.

Important

When the heating actuator mode is selected, the service life of the switching contacts must be considered, see [Technical data](#), from page 7.

This is essential if the output is used for a continuous controller.

Considering these aspects, it may be useful to use an Electronic Switch Actuator, Fan Coil-Actuator or controller from the ABB i-bus® KNX range. These actuators do not feature galvanic isolation and have a considerably smaller switching capacity, which is sufficient. Mechanical wear and switching noises are not an issue.

Note

The function current detection and the respective parameter window are only visible with the Switch Actuators with current detection (SA/S x.16.6.1). They are both equally available in the *Switch Actuator* and *Heating Actuator* modes.

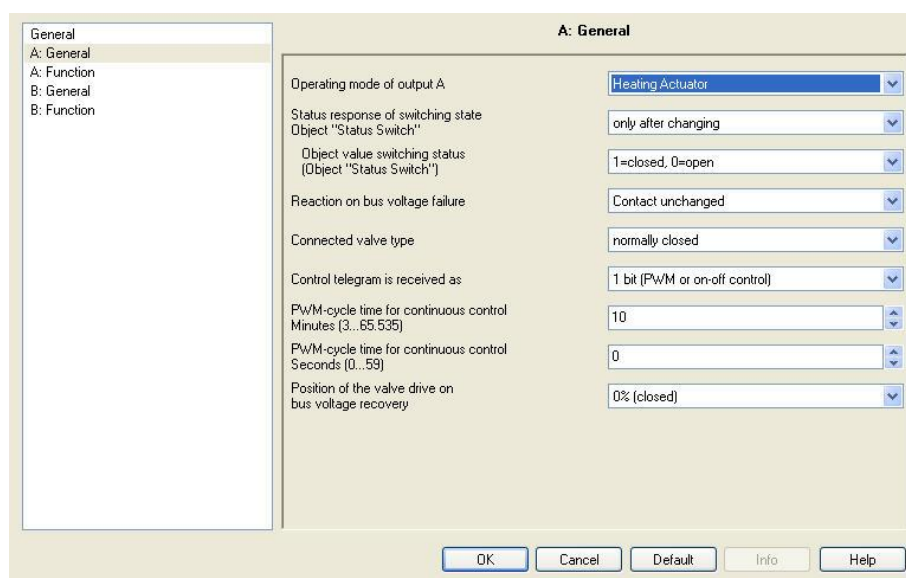

Status response of switching state Object "Status Switch"

Options: no
 after a change
 always

This parameter can enable the communication object *Status Switch*. This contains the current switching state and the present contact position.

- *no*: The switch state is updated but the status is not actively sent on the bus.
- *after a change*: With a change of the switch state, the status is actively sent on the bus via the communication object *Status Switch*. This can have a major affect on the bus load on a Switch Actuator with several outputs.
- *always*: The status of the switch state is always actively sent on the bus via the communication object *Status Switch*, even when a change in status has not occurred. Transmission is triggered as soon as the communication objects *Control value* or *Valve purge* receive a telegram.

Note

With a change of the parameterization or after a subsequent switching of the status object, the assignment of the group addresses already allocated to the *Switch* communication object is lost and needs to be reprogrammed.

The status value to be sent is defined with the parameter *Object value switching status (Object "Status Switch")*.

Note

The contact position results from the sequence of priorities and logical connections; refer for this purpose to [Function chart](#), page 192.

The contact position can only be correctly evaluated should the switching actions occur via KNX. The SA/S cannot differentiate between manual switching and a cable break or device fault.

**Object value switching status
(Object "Status Switch")**

Options: 1=closed, 0=open
 0=closed, 1=open

- *1=closed, 0=open*: The value 1 is written with a closed contact, and the value 0 is written with an open contact in the communication object *Status Switch*.
- *0=closed, 1=open*: The value 0 is written with a closed contact, and the value 1 is written with an open contact in the communication object *Status Switch*.

The reaction of the heating valve is dependent on the position of the Switch Actuator relay and the valve type (normally open or normally closed).

Reaction on bus voltage failure

Options: Contact open
 Contact closed
 Contact unchanged

This parameter defines how the contacts and accordingly the valve drives are controlled at bus voltage failure.

For further information see: [Reaction on bus voltage failure, recovery and download](#), page 197

Only the energy for the switching action is available when the bus voltage fails.

If a normally closed valve is used, a closed contact means an open valve (100 %) or a closed valve (0 %) with an open contact.

If a normally opened valve is used, a closed contact means a closed valve (100 %) or an opened valve (0 %) with an open contact.

A middle position of the valve can not be set with bus voltage failure. With a bus voltage failure, the valve moves either to its closed (0 %) or open (100 %) end position.

Connected valve type

Options: normally closed
normally open

Using this parameter, the valve type for the connected valve is set.

How does a normally closed valve behave?

If no current flows in the control circuit, the valve is closed. The valve is opened as soon as current flows in the control circuit.

How does a normally open valve behave?

If no current flows in the control circuit, the valve is opened. The valve is closed as soon as current flows in the control circuit.

Control telegram is received as

The heating actuator can either be controlled via the 1 bit communication object *Switch* or the 1 byte communication object *Control value (PWM)*.

Options: 1 bit (PWM or 2-step)
1 byte (continuous)

- *1 bit (PWM or on-off control)*: The room thermostat controls the heating actuator via standard switching telegrams. An on-off control of the control value is implemented in this way. The 1 bit value can originate from pulse width modulation (PWM), which a room thermostat has calculated. During a malfunction when the control signal is not received by the room thermostat, the Switch Actuator will undertake an autonomous PWM calculation. For this purpose, the SA/S uses the programmable PWM cycle time.
- *1 byte (continuous)*: A value of 0...255 (corresponds to 0 %...100 %) is preset by the room thermostat. This process is also known as "continuous-action control". At 0 %, the valve is closed, and at 100 % it is fully opened. The Heating actuator controls intermediate values via pulse width modulation.

For further information see: [Pulse width modulation \(PWM\)](#), page 194 and [Pulse width modulation – Calculation](#), page 195

With 1 byte (*continuous*) selected, an additional parameter appears:

Transmit status response

Object "Status heating"

Options: no
 yes, 0% = "0" otherwise "1" (1 bit)
 yes, 0% = "1" otherwise "0" (1 bit)
 yes, continuous control value (1 byte)

This parameter is only visible with continuous control with a 1 byte value.

For 2 step control, the current control value means the same as the communication object *Status Switch*.

- *no*: A control value is not reported back.
- *yes, 0% = "0" otherwise "1" (1 bit) and 0% = "1" otherwise "0" (1 bit)*
 The communication object *Status heating (1 bit)* is enabled. The current control value is sent.
- *continuous control value (1 byte)*: The communication object *Status heating (1 byte)* is enabled. The current control value is sent.

PWM-cycle time for continuous control Minutes (3...65,535)

Options: 3...10...65,535

PWM-cycle time for continuous control Seconds (0...59)

Options: 0...59

For 1 bit control, this time setting is only used during control of the actuator in fault mode, with the function *Forced operation* and directly after bus voltage recovery.

With a 1 byte control (continuous control), the periodic duration of the control signals are set with this setting. This corresponds with the cycle time t_{CYC} . The time has been limited to 3 minutes in order to suit the endurance of the switch relay, as the number of relay switching operations is limited.

For further information see: [Pulse width modulation \(PWM\)](#), page 194 and [Lifetime examination of a PWM control](#), page 196

Position of the valve drive on bus voltage recovery

Options: 0% (closed)
 10% (26)
 ...
 90% (230)
 100% (open)

This parameter sets how the valve drive is set after bus voltage recovery until the first switching or positioning telegram is received from the room thermostat. The Switch Actuator uses PWM control with the parameterised PWM cycle time until a signal is sent from the room thermostat.

The values in brackets correspond to a 1 byte value.

3.2.5.1 Parameter window A: Function

In this parameter window, you determine the behaviour of the output and can enable different functions, where further parameters windows become available.

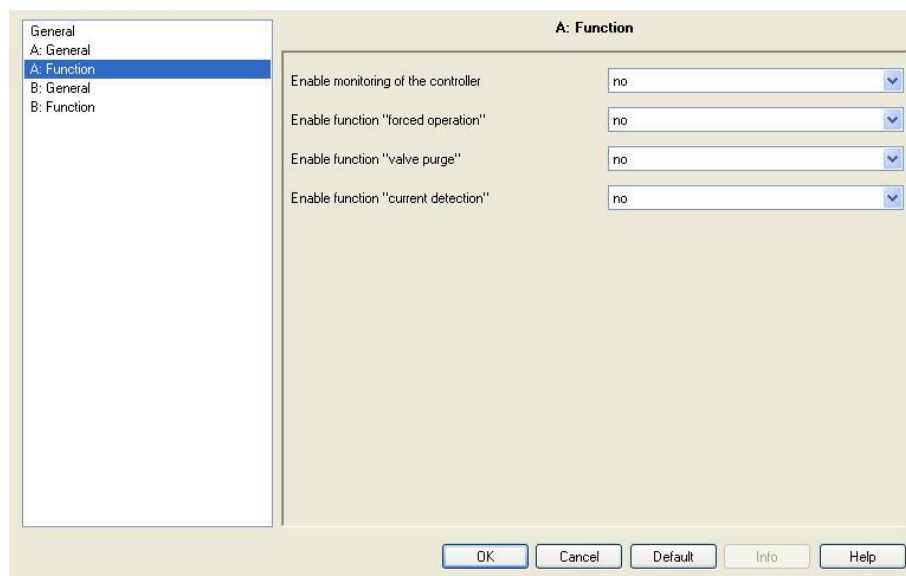

Monitoring of the controller

Options: no
yes

- *no*: The parameter window *A: Monitoring* for output A is not enabled.
- *yes*: The parameter window *A: Monitoring* for output A is enabled. There the communication object *RTR fault* can be enabled for monitoring. Thus a failure of the room thermostat can be detected, the output changed to fault mode and a parameterised valve position can be set.

Enable function "forced operation"

Options: no
yes

With forced operation, the output can assume a determined position, e.g. for inspection purposes.

- *no*: The parameter window *A: Forced Operation* for output A is not enabled.
- *yes*: The parameter window *A: Forced Operation* for output A as well as the communication object *Forced operation* are enabled.

Enable function "valve purge"

Options: no
 yes

Cyclic valve purge prevents deposits from forming in the valves.

- *no*: The parameter window *A: Valve purge* for output A is not enabled.
- *yes*: The parameter window *A: Valve purge* for output A as well as the communication objects *Trigger valve purge* and *Status valve purge* are enabled.

Enable function "current detection"

Options: no
 yes

- *no*: The parameter window *A: Current detection* for output A is not enabled.
- *yes*: The parameter window *A: Current detection* for output A as well as the communication object *Contact monitoring* are enabled.

Note

These parameters and their functions are only visible for Switch Actuators with current detection. The actuators with integrated current detection are recognisable by a number 6 on the third position of the type designation, e.g. S/S 2.16.6.1.

Send status via object "contact monitoring"

Options: no
 after a change
 always

The sending behaviour of the communication object *Contact monitoring* can be parameterized by the parameter. A contact fault is indicated via the communication object *Contact monitoring*. An error (value 1) is displayed as soon as a current of about 30 mA (observe the tolerances) is detected with an open contact.

- *no*: The value of the communication object is always updated but not sent.
- *always*: The switch status is updated and always sent when the contact is opened. No value is sent when closing the contact. The reset status is only sent with the next opening.
- *after a change*: A telegram is only sent if the value of the communication object *Contact monitoring* changes. Here the bus load, particularly for Switch Actuators with multiple outputs, can be influenced significantly.

Important

The contact position can only be correctly evaluated should the switching actions occur via KNX. The SA/S cannot differentiate between manual switching and a cable break or device fault. Evaluation of the contact monitoring occurs about two seconds after opening the contact.

3.2.5.1.1 Parameter window A: Monitoring

In this parameter window, all settings for the function *Monitoring* are undertaken.

This parameter is visible if in parameter window [A: Function](#), page 154, the parameter *Enable monitoring of the controller* has been enabled.

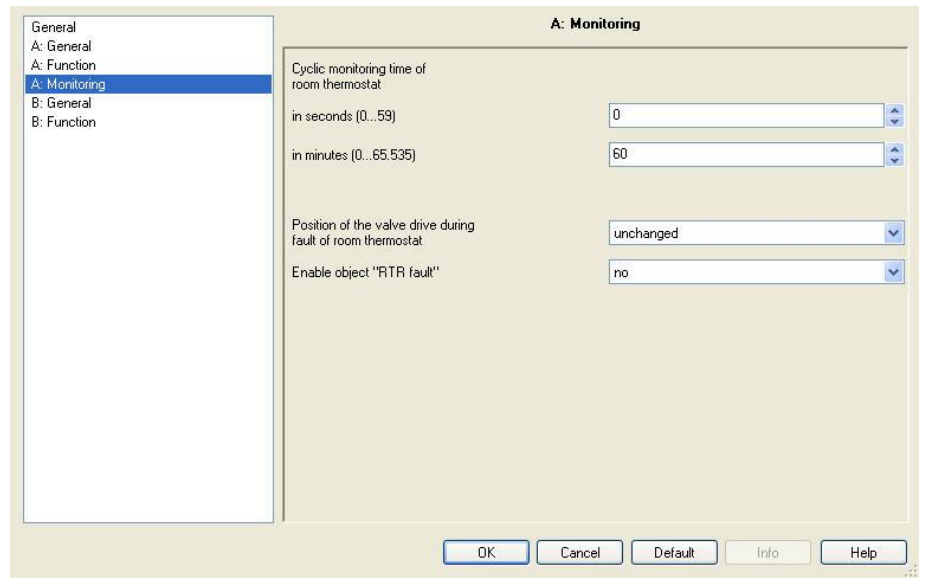

Cyclic monitoring time of thermostat in seconds (0...59)

Options: 0...59

in minutes (0...65,535)

Options: 0...60...65,535

The telegrams of the room thermostat are transferred to the electronic actuator at specific intervals. If one or more of the consecutive telegrams are omitted, this can indicate a communications fault or a malfunction in the room thermostat.

If there are no telegrams received by the communication objects *Switch* or *Control value (PWM)* during the period defined in this parameter, the output switches to fault mode and triggers a safety position. The fault mode is ended as soon as a telegram is received as a control value.

Note

If this parameter window is visible, the room thermostat must send the control value cyclically, otherwise no function monitoring is possible. The monitoring time should be twice as long as the sending cycle time to ensure that an error is not immediately signalled should the signal be absent once.

**Position of the valve drive during
fault of room thermostat**

Options: unchanged
 0% (closed)
 10% (26)
 ...
 90% (230)
 100% (open)

This parameter determines the safety position that is controlled in error mode by the SA/S. The values in brackets correspond to a 1 byte value.

The switch cycle time t_{CYC} used for control is to be programmed in the parameter *cycle time for continuous control* in parameter window A: *General*.

Enable object "RTR fault"

Options: no
 yes

Using this parameter, the communication object *Fault control value* can be enabled. During fault mode, the communication object has the value 1, if there is no fault the value is 0.

3.2.5.1.2 Parameter window A: Forced Operation

In this parameter window, all settings for the function *Forced operation* are undertaken.

This parameter is visible if in parameter window [A: Function](#), page 154, the parameter *Function forced operation* has been enabled.

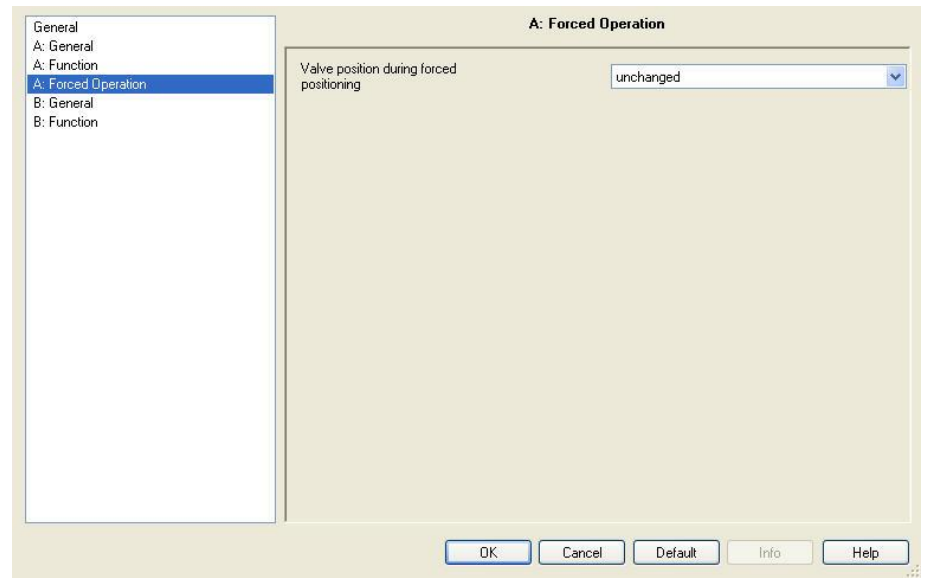

During a forced operation, the Switch Actuator triggers a freely adjustable forced position. This has the highest priority, i.e. it is not modified by a valve purge or safety position.

The forced operation (positioning) can be activated via the communication object *Forced operation = "1"* and deactivated via the communication object *Forced operation = "0"*.

Valve position during forced positioning

Options: unchanged
 0% (closed)
 10% (26)
 ...
 90% (230)
 100% (open)

The valve position triggered by the actuator during the forced operation is determined by this parameter. The values in brackets correspond to a 1 byte value.

The switch cycle time t_{CYC} used for control is to be programmed in the parameter *cycle time for continuous control* in parameter window *A: General*.

At the end of forced operation, the Switch Actuator returns to its normal method of operation and calculates its next switch state value from the incoming values on communication objects *Switch* or *Control value (PWM)*.

3.2.5.1.3 Parameter window A: Valve Purge

In this parameter window, all settings for the function *Valve purge* are undertaken.

This parameter is visible if in parameter window [A: Function](#), page 154, the parameter *Enable function "valve purge"* has been enabled.

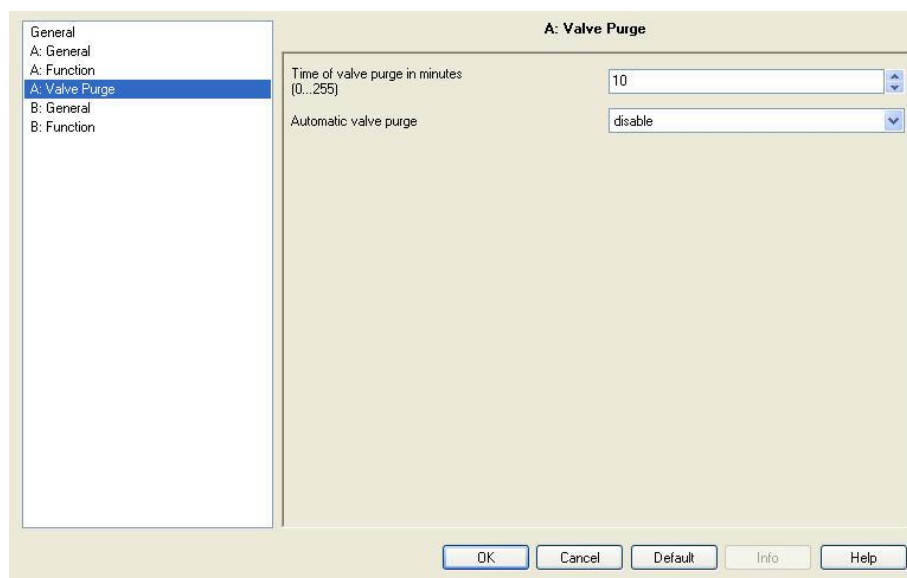

Regular purging of a heating valve can prevent deposits from forming in the valve area and restricting the valve function. This is particularly important at times when the valve position does not change very much. The valve is opened to the maximum during a valve purge. It can be triggered via the communication object *Trigger valve purge* and/or automatically at adjustable intervals.

Time of valve purge in minutes (1...255)

Options: 1...10...255

The time duration for the valve purge is set with this parameter. In this time the valve is fully opened. When the time has elapsed, the state before the purge is re-established.

Note

The opening time of the valve must be considered when entering the purge time.

The characteristic curve adjustment is active for the valve purging time.

Automatic valve purge

Options: no
 one times per day
 one times per week
 one times per month

The counter for automatic purging starts to run when the parameter is downloaded. The time is reset each time it is downloaded.

The time is reset as soon as purging is completed. This can occur either through automatic purging or via the communication object *Trigger valve purge*.

Note

Purging can also be triggered via the bus with the communication object *Trigger valve purge*.

After bus voltage recovery and download, the purge cycle continues, the bus failure time – the time for which the bus actually failed – is not considered.

An intermediate switching operation of the Switch Actuator relay does not affect the time, as it is not ensured that the valve stroke required for purging has been carried out.

3.2.5.1.4 Parameter window A: *Current Detection*

In this parameter window, all settings for the function *Current Detection* are undertaken.

This parameter is visible if in parameter window [A: Function](#), page 154, the parameter *Enable function "current detection"* has been enabled.

Note
<p>The function current detection and the respective parameter window are only visible with the Switch Actuators with current detection (SA/S x.16.6.1). They are both equally available in the <i>Switch Actuator</i> and <i>Heating Actuator</i> modes.</p> <p>As the function for the modes does not differ, refer to the descriptions of the parameter setting options and adjustable communication objects from parameter window A: Current Detection, page 95.</p>

3.2.6 Communications objects
Mode
Heating Actuator

3.2.6.1 Communication objects
General

No.	Function	Object name	Data type	Flags
0	In Operation	System	EIS 1, 1 bit DPT 1.002	C, T
<p>In order to regularly monitor the presence of the Switch Actuator on the ABB i-bus[®], a monitoring telegram can be sent cyclically on the bus. This communication object is always enabled.</p> <p>Telegram value: 1= system operational 0 = send inactive</p>				
1	Safety Priority 1	General	EIS 1, 1 bit DPT 1.005	C, W, U
<p>This communication object is enabled if in parameter window <i>General</i> the parameter <i>Function Safety Priority 1</i> is selected with the option <i>enabled by object value "0"</i> or <i>enabled by object value "1"</i>.</p> <p>The Switch Actuator can receive a 1 bit telegram via this communication object, which another KNX device, e.g. diagnostics module or wind sensor, sends cyclically. On receipt of the telegram, the communication capability of the bus or the sensor (signalling device) can be monitored. If the Switch Actuator does not receive a telegram (value can be programmed) on the communication object <i>Safety Priority 1</i>, a fault is assumed, and a response programmed in parameter window <i>A: Safety</i> is implemented. The output of the Switch Actuator goes into a safety state and does not process any telegrams. Only after the communication object <i>Safety Priority 1</i> again receives a 1 or 0 (depending on the parameterization) will incoming telegrams be processed again and the contact setting changed.</p> <p>The control period can be adjusted in the parameter <i>Control period in seconds</i>.</p> <p>The safety priority 1 is also triggered if a telegram with the programmable trigger value is received.</p>				

No.	Function	Object name	Data type	Flags
2	Safety Priority 2	General	EIS 1, 1 bit DPT 1.005	C, W, U
See communication object 1				
3	Safety Priority 3	General	EIS 1, 1 bit DPT 1.005	C, W, U
See communication object 1				
4... 9				
Not assigned.				

3.2.6.2 Communication objects
Output A

Note
<p>In this product manual, all the current 2/4/8 and 12-fold Switch Actuators are described. These devices each have 2/4/8 or 12 outputs. However, as the functions for all outputs are identical, only the functions of output A will be described.</p> <p>Should the details in the product manual refer to all outputs, 2-fold corresponds to outputs A...B, 4-fold corresponds to outputs A...D, 8-fold corresponds to outputs A...H and 12-fold corresponds to outputs A...L; the designation outputs A...X is used.</p> <p>The variants with current detection feature an additional parameter page as well as additional communication objects for this function.</p>

The descriptions of the parameter setting options of Outputs A...X are described from parameter window [A: General](#), page 60.

No.	Function	Object name	Data type	Flags
10	Switch	Output A	EIS 1, 1 bit DPT 1.001	C, W
<p>This communication object is visible if the control of the heating actuator is implemented via a 1 bit communication object. The heating valve is controlled directly using it. The device receives a switch telegram via the switch object.</p> <p>Normally open: Telegram value 1 = valve open 0 = valve closed</p> <p>Normally closed contact: Telegram value 1 = valve closed 0 = valve open</p>				
10	Control value (PWM)	Output A	EIS 6, 1 byte DPT 5.010	C, W
<p>This communication object is visible if the control of the heating actuator is implemented via a 1 bit communication object, e.g. within a continuous control. The communication object value (0...255) is determined by the variable mark-to-space ratio of the valve.</p> <p>Telegram value 1 = valve closed 0 = valve open</p>				

No.	Function	Object name	Data type	Flags
11	Trigger valve purge	Output A	EIS 1, 1 bit DPT 1.001	C, W
<p>This communication object is enabled if in parameter window <i>A: Function</i> the parameter <i>Enable function "valve purge"</i> has been selected with the option <i>yes</i>.</p> <p>The valve purge is triggered using this communication object.</p> <p>Telegram value: 0 = end valve purge, valve will be closed 1 = start valve purge, valve will be opened</p>				
12	Status valve purge	Output A	EIS 1, 1 bit DPT 1.002	C, T
<p>This communication object is enabled if in parameter window <i>A: Function</i> the parameter <i>Enable function "valve purge"</i> has been selected with the option <i>yes</i>.</p> <p>The status of the valve purge is visible via this communication object.</p> <p>Telegram value: 0 = valve purge not active 1 = valve purge active</p> <div style="border: 1px solid black; padding: 5px; margin: 10px 0;"> <p>Note</p> <p>The status is displayed as soon as a purge has been activated. The status remains active, even when the purge has been interrupted, e.g. by a priority.</p> </div>				
13	RTR fault	Output A	EIS 1, 1 bit DPT 1.005	C, T
<p>This communication object is enabled if in parameter window <i>A: Function</i> the parameter <i>Enable monitoring of the controller</i> has been selected with the option <i>yes</i>.</p> <p>Using this communication object, both communication objects <i>Switch</i> and <i>Control value (PWM)</i> can be cyclically monitored. If the values of the room thermostat (RTR) remain absent, the device assumes that the thermostat has a malfunction and signals a fault.</p> <p>Telegram value: 1 = fault 0 = no fault</p>				
14	Forced operation	Output A	1 bit (EIS 1) DPT 1.003	C, W
<p>This communication object is enabled if in parameter window <i>A: Function</i> the parameter <i>function "forced operation"</i> has been selected with the option <i>yes</i>.</p> <p>If the object receives the value 1, the valve is forcibly moved to the parameterised position, which has been set in the parameter window <i>A: Forced operation</i>.</p> <p>The forced positioning of the valve should remain until forced operation is ended. This is then the case when a 0 is received via the communication object <i>Forced operation</i>.</p> <p>Please note that the function <i>Forced operation</i> and a bus voltage failure have a higher priority on the switching state, see Function chart, page 177.</p>				

No.	Function	Object name	Data type	Flags
15	Status heating	Output A	EIS 6, 1 byte DPT 5.010	C, T
<p>This communication object is visible if the control of the heating actuator is implemented via a 1 bit communication object, e.g. within a continuous control, and the feedback of the control value is parameterised with a 1 byte value.</p> <p>The current 1 byte control value of the output is sent via this communication object.</p>				
15	Status heating	Output A	EIS 1, 1 bit DPT 1.001	C, T
<p>This communication object is visible if the control of the heating actuator is implemented via a 1 bit communication object, e.g. within a continuous control, and the feedback of the control value is parameterised with a 1 bit value.</p> <p>The current 1 bit control value of the output is sent on a change via this communication object.</p> <p>With the selection of the option 0% = "0" otherwise "1", the following applies:</p> <p style="padding-left: 40px;">Telegram value: 1 = control value is not equal to 0 % 0 = control value is equal to 0 %</p> <p>With the selection of the option 0% = "1" otherwise "0", the following applies:</p> <p style="padding-left: 40px;">Telegram value: 1 = control value is equal to 0 % 0 = control value is not equal to 0 %</p>				
16... 24				
Not assigned.				
25	Contact monitoring	Output A	EIS 1, 1 bit DPT 1.002	C, R, T
<p>This communication object is enabled if in parameter window A: <i>Function</i> the parameter <i>Enable function "current detection"</i> has been selected with the option <i>yes</i>.</p> <p>The communication object value shows the contact state when the contact is open.</p> <p>Should a current flow be detected with an opening of the contact initiated via the KNX, contact welding or manual switch on has occurred (contact fault). The evaluation of whether a current flows occurs about one second after a contact is opened. The current is safely detected should a measurable current (about 20 mA) flow. A prerequisite for correct evaluation is switching via the KNX.</p> <p style="padding-left: 40px;">Telegram value 1 = contact error 0 = no current flows</p>				

No.	Function	Object name	Data type	Flags
26	Current Value	Output A	EIS 10, 2 byte DPT 7.012	C, R, T
<p>This communication object is enabled if in parameter window A: <i>Function</i> the parameter <i>Enable function "current detection"</i> has been selected with the option yes and in the parameter window A: <i>Current Detection</i> of the 2 byte data type.</p> <p>The presently detected current is sent on the KNX. 1 digit corresponds to 1 mA.</p> <p>For further information see: Current detection specifications, page 37</p>				
26	Current Value	Output A	EIS 9, 4 byte DPT 14.019	C, R, T
<p>This communication object is enabled if in parameter window A: <i>Function</i> the parameter <i>Enable function "current detection"</i> has been selected with the option yes and in the parameter window A: <i>Current Detection</i> of the 4 byte data type.</p> <p>The current value is transferred as a mA value on the KNX.</p> <p>For further information see: Current detection specifications, page 37</p>				
27	Status Current-Threshold 1	Output A	EIS 1, 1 bit DPT 1.002	C, R, T
<p>This communication object is enabled if in parameter window A: <i>Current Detection</i> the parameter <i>Enable current threshold value(s)</i> has been selected with the option yes.</p> <p>The status of the current threshold 1 is only sent when a change occurs.</p> <p>The status value can be inverted.</p> <p>Telegram value 1 = threshold 1 plus threshold 1 hysteresis is exceeded 0 = threshold 1 minus threshold 1 hysteresis is exceeded</p> <p>For further information see: Function threshold with current detection, page 171</p>				

No.	Function	Object name	Data type	Flags
28	Status Current-Threshold 2	Output A	EIS 1, 1 bit DPT 1.002	C, R, T
<p>This communication object is enabled if in parameter window <i>A: Current Detection</i> the parameter <i>Enable current threshold value(s)</i> and the parameter <i>Enable current threshold 2</i> has been selected with the option <i>yes</i>.</p> <p>The status of the current threshold 1 is only sent when a change occurs.</p> <p>The status value can be inverted.</p> <p>Telegram value 1 = threshold 2 plus threshold 2 hysteresis is exceeded 0 = threshold 2 minus threshold 2 hysteresis is exceeded</p> <p>For further information see: Function threshold with current detection, page 171</p>				
29	Status Switch	Output A	EIS 1, 1 bit DPT 1.001	C, R, T
<p>This communication object is enabled if in parameter window <i>A: General</i> the parameter <i>Status response of switching state Object "Status Switch"</i> or the option <i>always</i> have been selected.</p> <p>The communication object value directly indicates the current contact position of the switching relay.</p> <p>The status value can be inverted.</p> <p>Telegram value 1 = relay ON or OFF depending on the parameterization 0 = relay OFF or ON depending on the parameterization</p>				

4 Planning and application

In this section, you will find some tips and application examples for practical use of the ABB i-bus[®] Switch Actuators.

4.1 Current detection

The current detection feature opens many new fields of application for the Switch Actuators. The following list contains a few examples:

- Load current flow detection (from 20 mA)
- Detection of significant equipment failure
- Preventative recognition of failures by continuous current monitoring
- Actual recording of operating hours
- Signalling of maintenance and service work
- Detection of open circuits
- Recording of switch operations per period
- Energy and load management
- Monitoring and signalling

Note

Only load currents with a sine wave characteristic can be detected correctly. For other signal types, e.g. phase angle or inverse phase angle control signals, the detected current value is distorted. In this case, the measured value is meaningless.

Current values less than 20 mA are indicated as a 0 mA value on the KNX. For small load currents that are just above the minimum detection threshold of 20 mA, it is possible that a value of 0 mA is displayed due to the inaccuracies, even though a current is flowing.

The function current detection and monitoring should only be used for safety relevant applications. The Switch Actuator cannot assume the function of a circuit-breaker or RCD (earth-leakage circuit breaker).

If the load current detection is used for equipment fault detection that only causes a slight change of less than 30 mA, mains voltage and current fluctuations due to ambient influences, e.g. temperature and natural ageing of the device play a significant role. Even when the current changes are detected by the Switch Actuator, the detected current changes do not necessarily mean that a device has malfunctioned.

In the following, there are some application examples described in more detail for current detection.

4.1.1 Function threshold with current detection

The function current detection features two independent thresholds. The detected current value will fluctuate by about 20 mA due to the necessary analogue/digital conversion of the detected load current. In order to avoid a continuous change of the threshold value state, the thresholds for current recognition feature a hysteresis function. The width of the hysteresis band is determined by the programmable hysteresis thresholds.

Example: Hysteresis curve, parameterization: *overshoot 1 – undershoot 0*

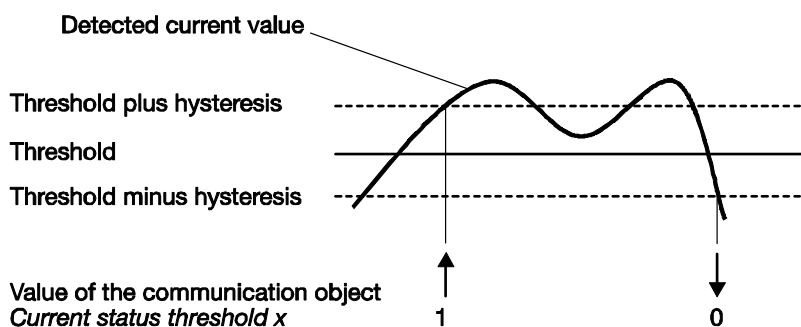

Should the upper hysteresis threshold be overshoot or the lower hysteresis threshold be undershot, the value of the communication object *Status Current-Threshold x* is modified and sent on the bus. This object value can be parameterised in parameter window *A: Current Detection*.

4.1.2 Display operating states

A Switch Actuator with current detection is predestined for displaying and recording operating states of electrical loads.

The operating state is detected indirectly via the load current. If the load current exceeds a threshold, an ON telegram is sent via the bus, if the value drops below the threshold, an OFF telegram is issued. This ON/OFF telegram can be received for example by a Universal Concentrator and displayed on the display panel.

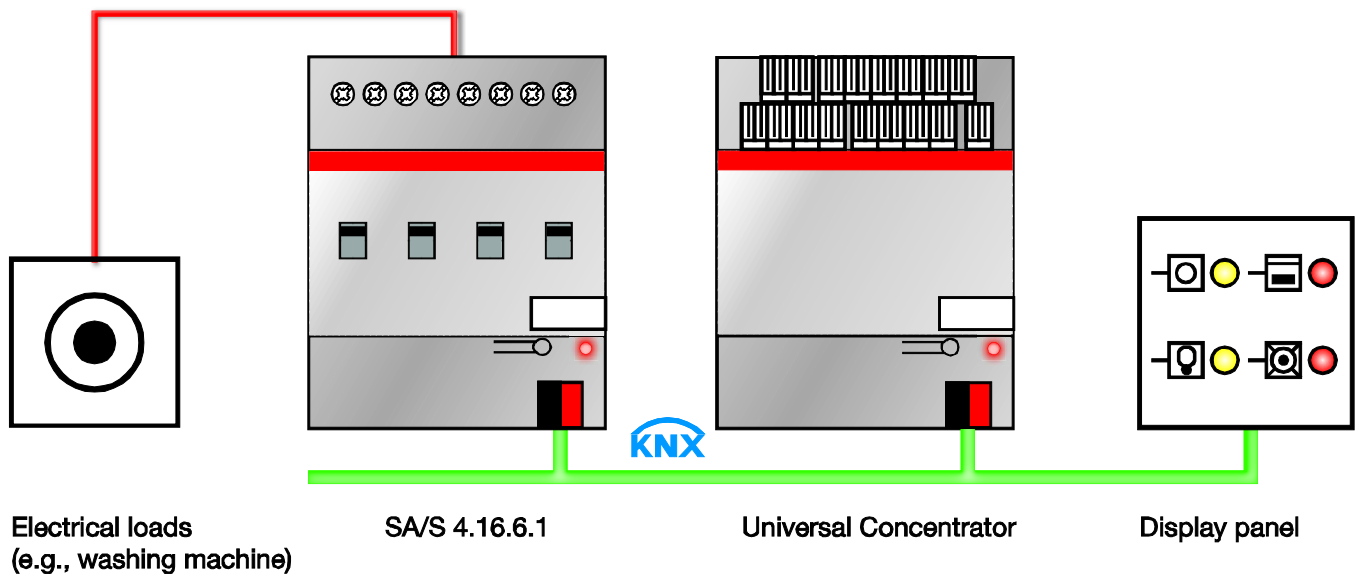

4.1.3 Recoding of operating hours

With the help of current detection in the Switch Actuator and a separate meter or counter element, it is possible to record, signal and display the actual electrical operating hours of electrical loads. This function can be used in facility management or for preventative maintenance and service planning. Filter exchange in air-conditioning systems or the exchange of lamp elements can be optimised and planned in advance.

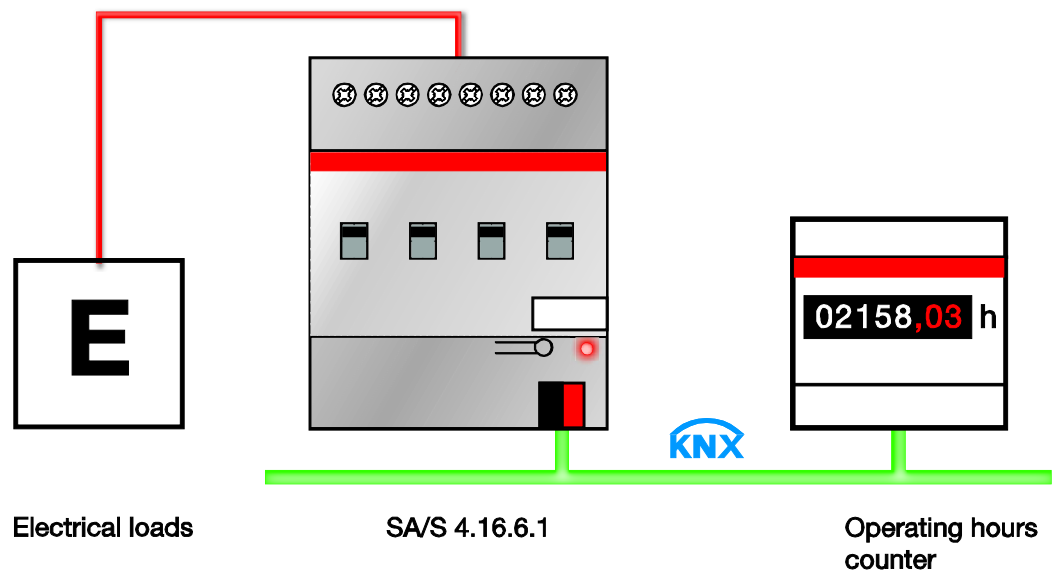

4.1.4 Trend analysis

Trend analysis is used to monitor the states of electrical systems over long periods and to receive early warnings of possible defects. The system operator can use this information for planning and carrying out his inspections and to undertake a repair, before the system fails.

Example: Should the current value change, telegrams are sent on the bus. These telegrams can be evaluated on a PC and can be displayed as a diagram using visualisation software. Changes which occur over an extended period are easily recognisable. If the trend analysis is combined with protocolling, a defective device can be quickly and easily identified.

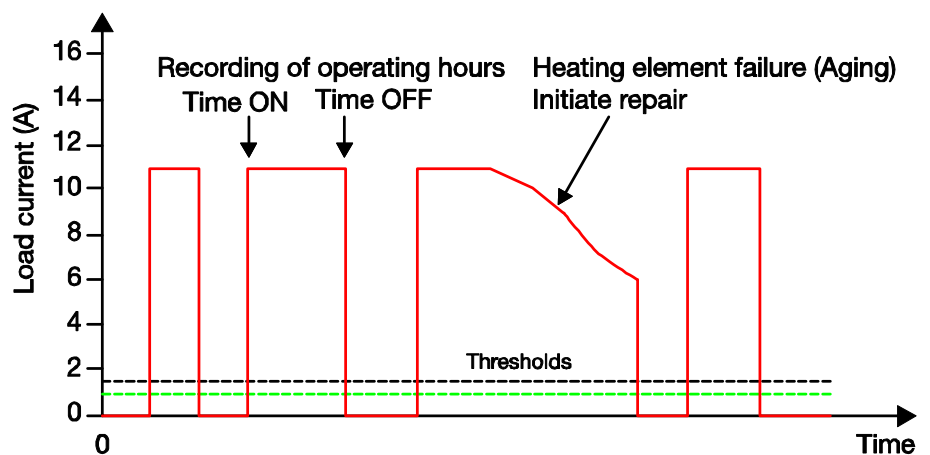
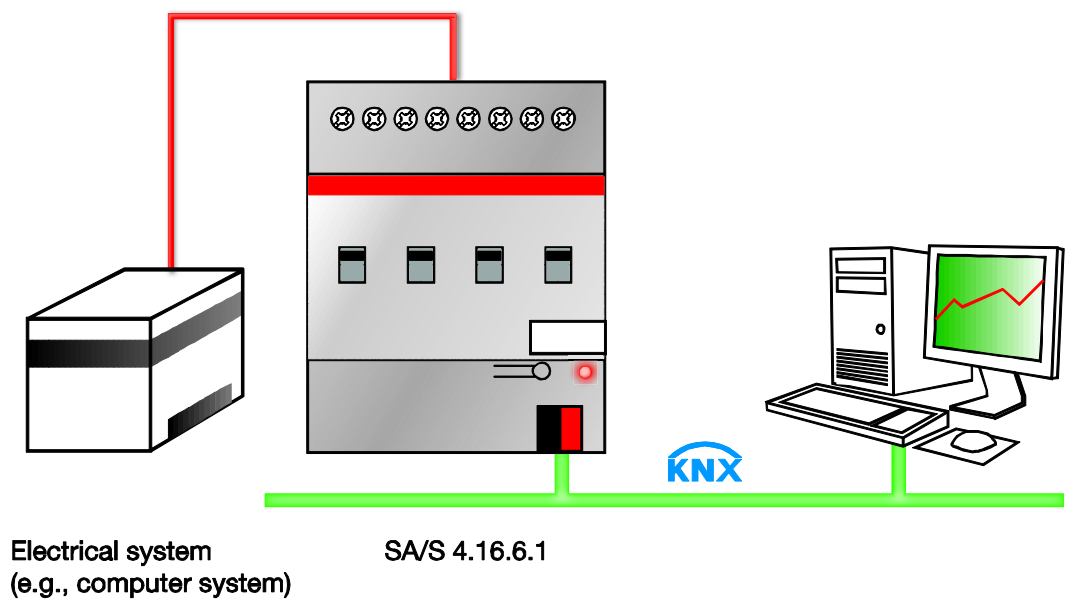

4.1.5 Current display

The Switch Actuators with current detection are no current measurement devices.

The recognised current with its tolerances (see [Technical data](#), page 7), can be displayed.

Using the KNX, this current value can be sent to a complex maintenance centre or a simple LCD display, e.g. a panel. Further processing or display is possible. Hereby, real-time monitoring or facility management of the installation is possible.

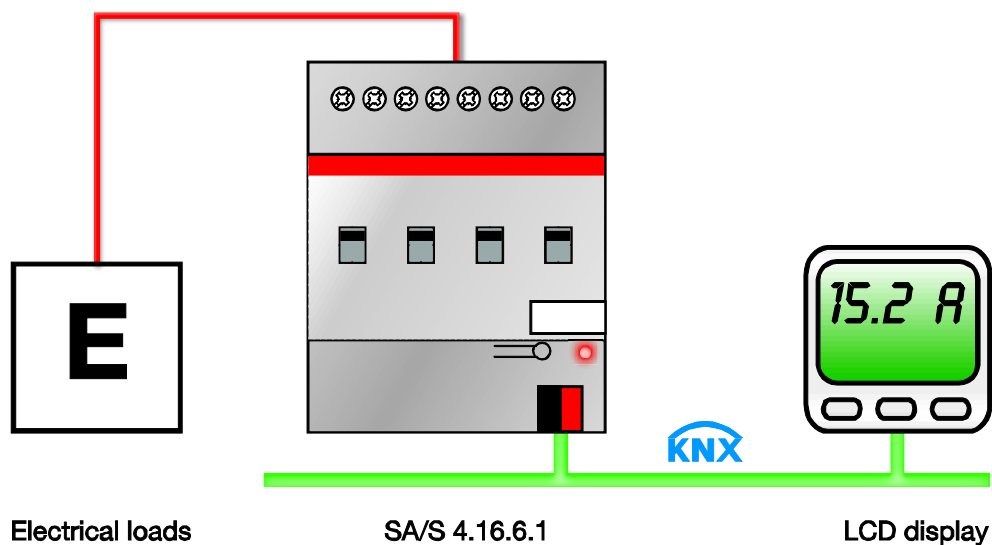

4.2 Operating mode *Switch Actuator*

4.2.1 Function chart

The following illustration indicates the sequence, in which the functions are processed. Communication objects, which lead to the same box, have the same priority and are processed in the sequence, in which the telegrams are received.

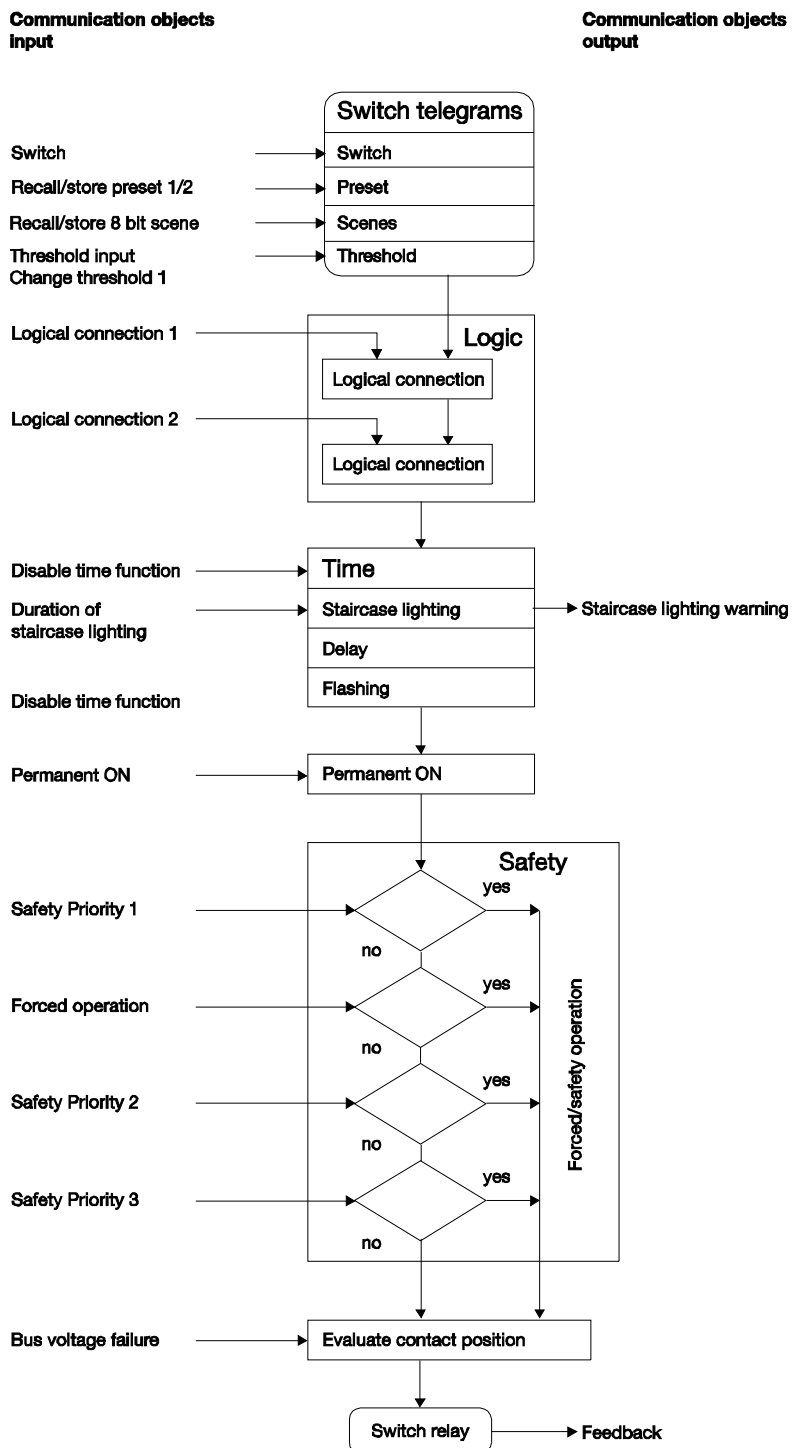

Example

If both communication objects *Logical connection x* are activated, a telegram received via a communication object *Switch* is connected to them. The result of this action serves as the input signal for the time function. If this is not blocked, a corresponding switch signal is generated, e.g. delay or flashing. Before the switch telegram of the relay is reached, the communication objects *Safety priority x* and *Forced operation* are checked and undertaken, if required, as a priority. Subsequently, the switching action is only dependent on the state of the bus voltage. The relay is switched if a switching action allows it.

4.2.2 Function Time

The function *Time* can be enabled (value 0) and disabled (value 1) via the bus (1 bit communication object *Disable function time*). The output operates without a delay as long as the function *Time* is disabled.

Different functions can be realised using the function *Time*:

- Staircase light
- Switching ON and OFF delay
- Flashing

4.2.2.1 Staircase light

The output switches off automatically after the staircase lighting time T_{ON} . For every telegram with the value 1, the staircase lighting time restarts ("*retrigger function*"), unless the parameter *Extending staircase lighting by multiple operation ("pumping up")* in parameter window [A: Time](#), page 70, is set to *no, no pump up possible*.

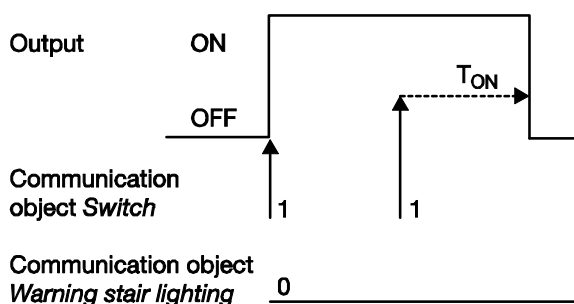

This corresponds with the basic response of the function *Staircase lighting*, as long as a warning is not parameterised.

Warning

An additional warning function enables the user to be warned in good time before the staircase lighting time elapses. It can be carried out by switching the output on/off briefly or by sending a communication object.

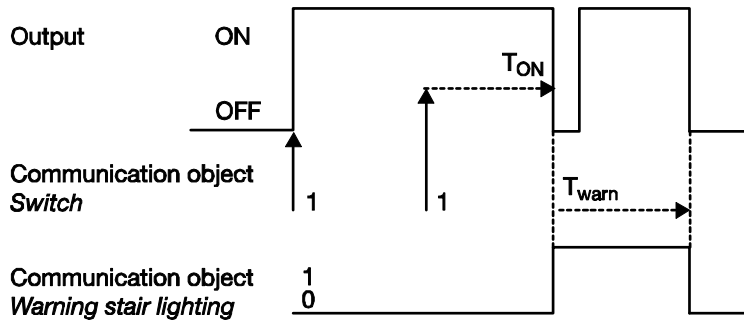

The warning time T_{WARN} extends the ON phase. At the start of the warning time, the output can be briefly switched on and off and/or the communication object *warning stair lighting* can be written with the value 1. The output is switched off briefly for the period T_{WARN} , before the staircase lighting time T_{ON} elapses and the communication object *warning stair lighting* is sent. As a result, for example, half of the lighting is switched off and a LED is switched on as a warning.

The entire staircase lighting time, in which the staircase lighting is on, corresponds with the time period T_{ON} plus T_{WARN} .

Retriggering

Via “pumping up” – actuation of the push button several time in succession – the user can adapt the staircase lighting to current needs. The maximum duration of the staircase lighting time can be set in the parameters.

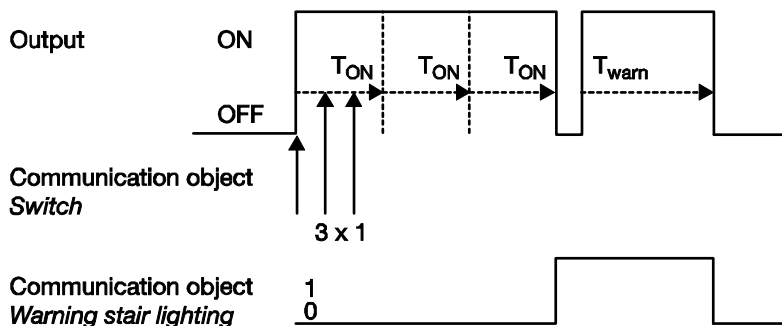

If the device receives a further ON telegram when the staircase lighting is switched on, the staircase lighting time is added to the remaining period.

The warning time is not changed by "pumping" and is added to the extended ON time (x times T_{ON}).

Application examples:

- Lighting control in stairwells
- Monitoring of telegrams

4.2.2.2 Switching ON and OFF delay

The switching ON and OFF delay delays switch on or switch off of the output.

Example 1:

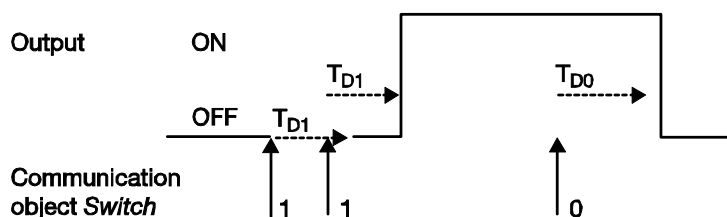

Example 2:

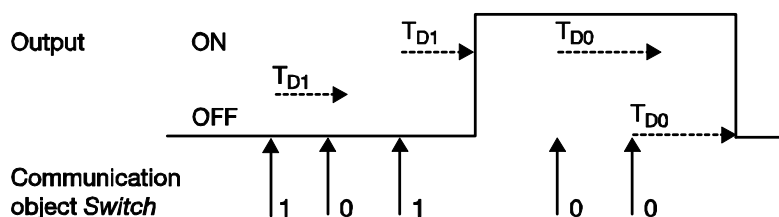

The delay time T_{D1} or T_{D0} starts after a switch telegram, and after it has timed out, the output executes the switch telegram.

If a new ON telegram with the value 1 is received during the switch on delay, the time of the switch on delay starts again. The same applies to switch off for the switch off delay. If a new OFF telegram with the value 0 is received during the switch off delay, the time of the switch off delay starts again.

Note

If the device receives an OFF telegram during the switch on delay T_{D1} , an ON telegram is disregarded.

4.2.2.3 Flashing

The output can flash when the output is switched on and off periodically.

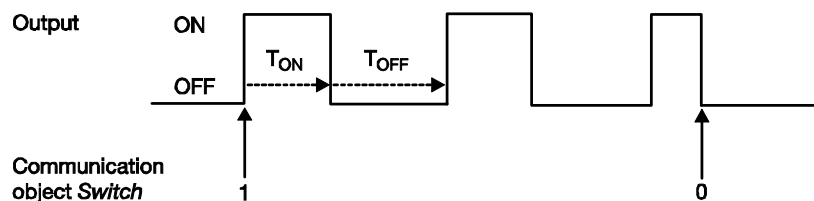

The switch on time (T_{ON}) and switch off time (T_{OFF}) during flashing can be programmed.

Note

The contact life of the contacts should be considered and can be found in the technical data. A limitation of the number of switching operations with the parameter *Number of impulses* may be useful.

Furthermore, a delay in the switching sequence is possible caused by the limited availability of switching energy with very frequent switching. The possible number of switching operations should be considered.

4.2.3 Function Connection/Logic

With the function *Connection/Logic* it is possible to connect the switching of the output with certain conditions.

Two connection objects are available:

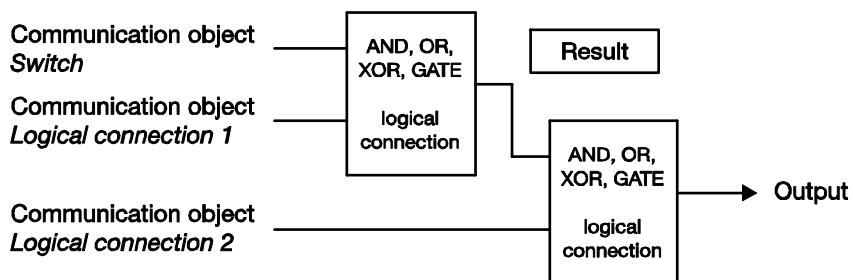

At first, the communication object *Logical connection 1* is evaluated with the communication object *Switch*. The result is then logically linked with the communication object *Logical connection 2*.

The following logic functions are possible:

Object values						Explanations
Logical function	Switch	Connection 1	Result	Connection 2	Output	
AND	0	0	0	0	0	The result is 1 if both input values are 1. The output is 1 if both input values are 1.
	0	1	0	1	0	
	1	0	0	0	0	
	1	1	1	1	1	
OR	0	0	0	0	0	The result is 1 if one of both input values is 1.
	0	1	1	1	1	
	1	0	1	0	1	
	1	1	1	1	1	
XOR	0	0	0	0	0	The result is 1 when both input values have a different value.
	0	1	1	1	0	
	1	0	1	0	1	
	1	1	0	1	1	
GATE	0	disabled	–	disabled	–	The communication object (CO) <i>Switch</i> is only allowed through if the GATE (connection) is open. Otherwise, the receipt of the CO <i>Switch</i> is ignored.
	0	enabled	0	enabled	0	
	1	disabled	–	disabled	–	
	1	enabled	1	enabled	1	

The logic function is always re-calculated when an object value is received.

Example Gate function

- The GATE logic is programmed, so that a disable is implemented as soon as the communication object *Logical connection x* receives a 0.
- The output of the logical connection is 0.
- The communication object *Logical connection 1* receives a 0, i.e. the GATE blocks.
- The communication object *Switch* receives 0, 1, 0, 1. The output of the logical connection remains 0.
- The communication object *Logical connection x* receives a 1, i.e. the GATE is enabled. The enabling condition (value 0 or 1) can be parameterised.
- The output of the logical connection is recalculated.

Note

The values of the communication objects *Logical connection 1/2* are stored at bus voltage failure. The values are restored at bus voltage recovery.

If values of the communication objects *Logical connection 1/2* were not assigned, they will be deactivated.

At a reset via the bus, the values of the communication objects *Logical connection 1/2* remain unchanged.

Note

With the SA/S x.16.6.1 and SA/S x.16.5.1 the current switch status is sent via the communication object *Status Switch* if a telegram is received via the communication objects *Logical connection x*. The prerequisite is that the sending performance of the switch status (see parameter window [A: General](#), page 60) is parameterized with *send always*.

4.2.4 Function Preset

A parameterizable switching state can be retrieved with the help of presets. Light scenes can therefore be implemented for example with a 1 bit communication object.

Retrieve preset

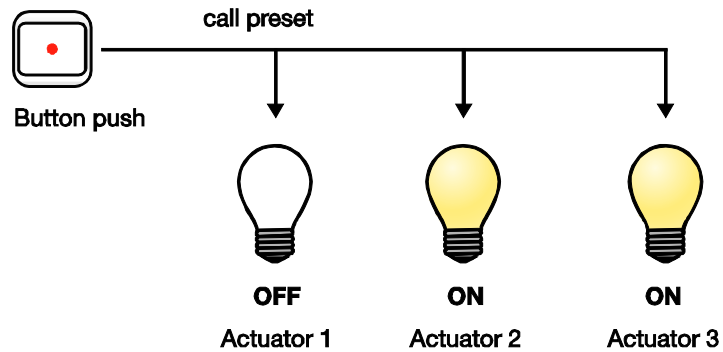

Switch states (“preset values”) can be retrieved via the communication objects *Recall preset 1/2*. A maximum of two preset values are available for each output:

Action	Telegram
Recall preset 1	Communication object Recall Preset 1/2 = 0
Recall preset 2	Communication object Recall Preset 1/2 = 1

Store preset

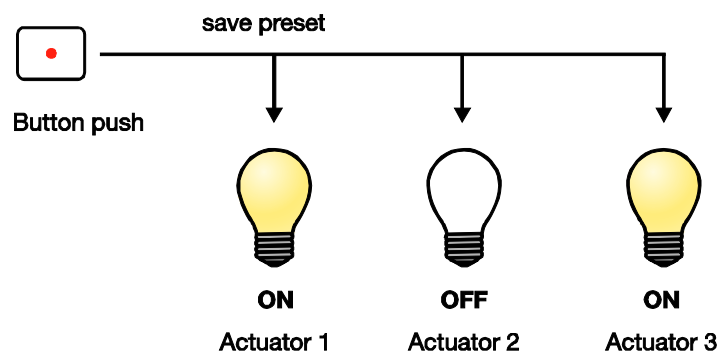

The current switching state is stored as a new preset value via the communication object *Set preset 1/2*. The user can, for example, adapt a lighting scene in this way. The presets are stored via the following values:

Action	Telegram
Save preset 1	Communication object Set preset 1/2 = 0
Save preset 2	Communication object Set preset 1/2 = 1

Special function: Restore state

A useful special function can be assigned to Preset 1. It is possible to recreate the brightness level (states), which were present before retrieving Preset 2.

The following diagram clarifies this:

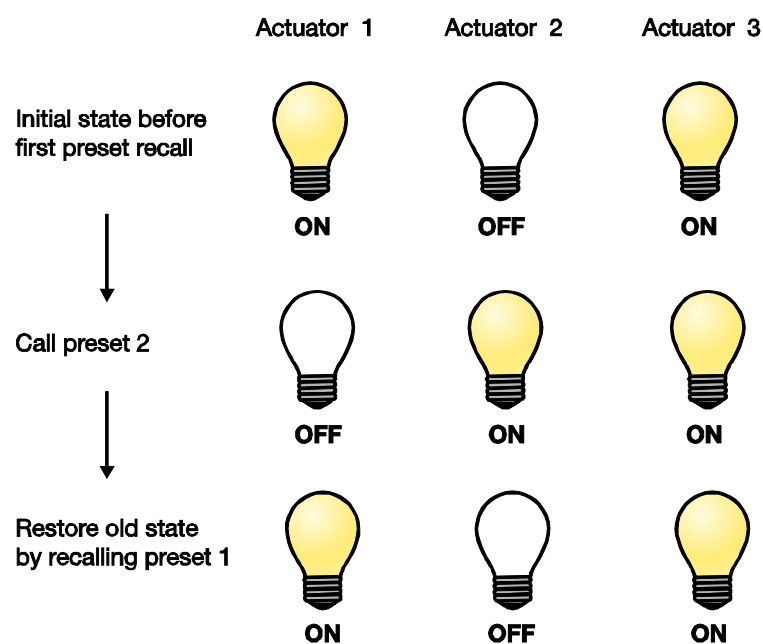

This function can be used for example after a presentation to restore the lighting to the state it was in beforehand.

4.2.5 Function Scene

With the scene using 8 bits, the push button issues the Switch Actuator with the instruction to call a scene. The scene is not stored in the push button but rather in the Switch Actuator. All Switch Actuators are addressed using the same group address. It is thus sufficient to send a single telegram to recall the scene.

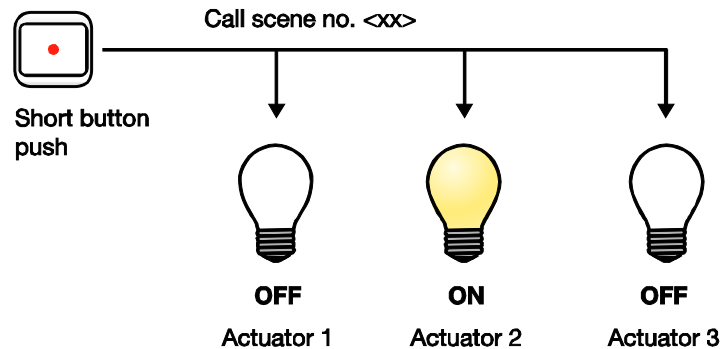

A scene number is sent with the telegram value, which must correspond with the scene number in the parameters of the Switch Actuator.

Up to 64 different scenes are managed via a single group address. The scene telegram contains the call or store functions of a scene.

In the following, the scene function is described, which controls multiple KNX devices.

With the scene it is possible to retrieve one of 64 scenes or to connect multiple KNX devices in a scene. The scene can be retrieved or stored using a single telegram. It is a prerequisite that all the operating devices are parameterised with the same scene number.

Each KNX device involved receives the scene telegram and independently controls the scenes values. Via the Switch Actuator, for example, the outputs are switched on or off, the Blind Actuator moves the blinds to a defined position, and the DALI Gateway dims its output to the pre-programmed brightness values.

Up to 64 different scenes can be managed via a single KNX group address. The following information is contained in a scene telegram:

- Number of the scene (1...64)
- Retrieve scene / store scene

For further information see: [Code table](#), page 201

Benefits

The function *Scene* with ABB i-bus® devices offers the following decisive advantage:

All settings to be undertaken in a scene are stored in the device. Therefore, they must not be sent via the KNX with a scene recall, and only a figure value that has been assigned to this scene is necessary. This considerably reduces the load on the bus and prevents unnecessary telegram traffic on the KNX.

A typical function *Scene* could, for example, appear as follows and is described using the 8 bit scene telegram as an example:

The task is to implement the room lighting for a presentation with ABB i-bus® devices. The following devices are used in the room:

- Switch Actuator for the basis lighting
- Blind Actuator for shading
- DG/S for dimmable lighting
- 1-10 V light controller for brightness detection and constant lighting control

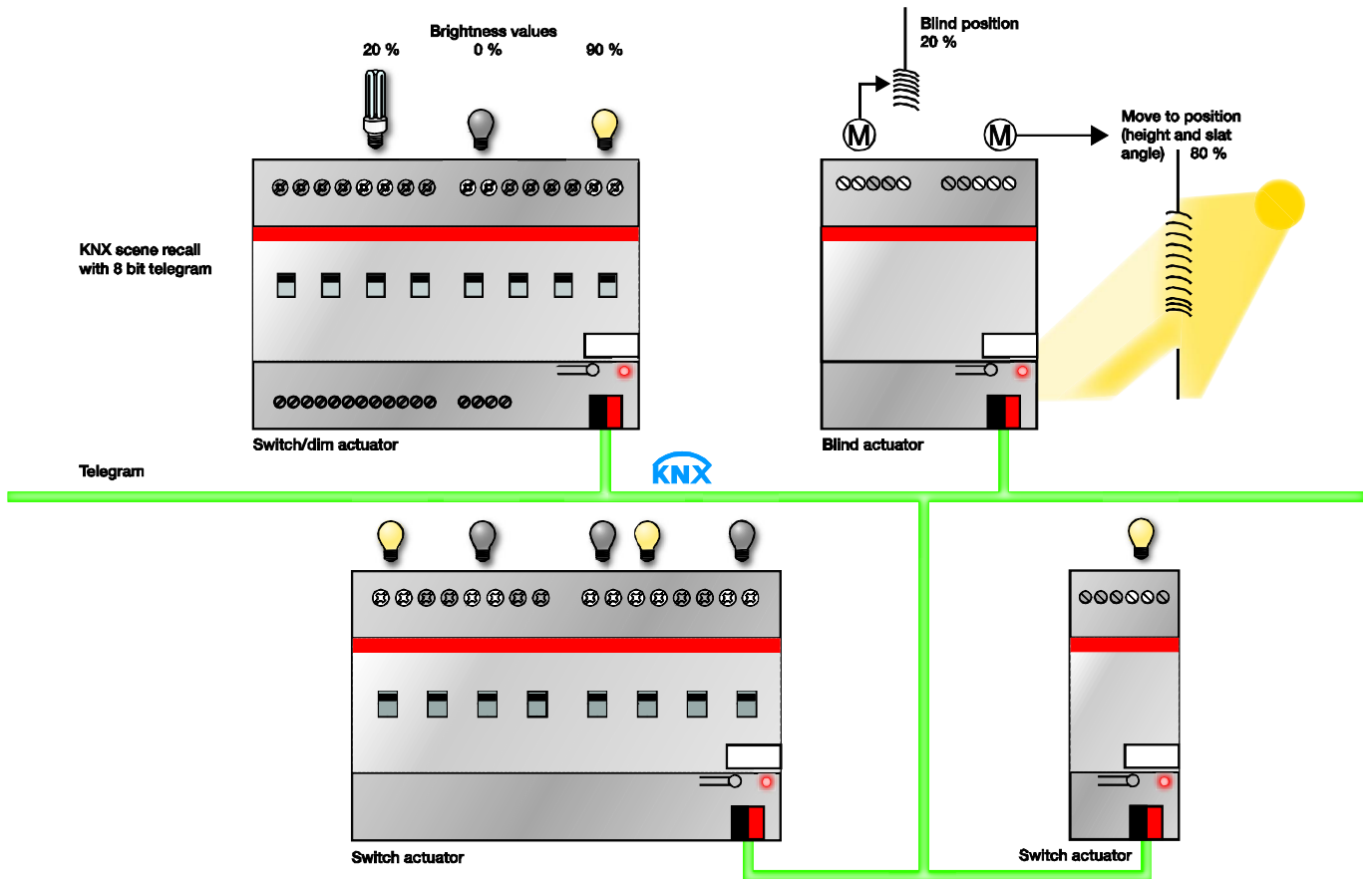

Example

An 8 bit scene (no. 8) comprises of some lamps, which are connected for switching to Switch Actuators and dimming e.g. to Switch/Dim Actuator. Furthermore, two blinds are integrated via a Blind Actuator. The Scene 8 can be retrieved via a single KNX telegram. The prerequisite for this is that all channels have programmed with scene 8. After a telegram has been received the blinds moves to the corresponding position; the lighting assumes the predefined brightness value and the switching status defined by Scene 8.

Note

The scene numbering 1 to 64 is retrieved via the KNX with a telegram number 0 to 63. For the corresponding scene coding see [Code table scene \(8 bit\)](#), page 201.

4.2.6 Function *Threshold*

The function threshold monitors a 1 byte or 2 byte value. As soon as this value exceeds or falls below a threshold value, the output can be switched. The threshold values can be interpreted as hysteresis values:

Threshold values are hysteresis values

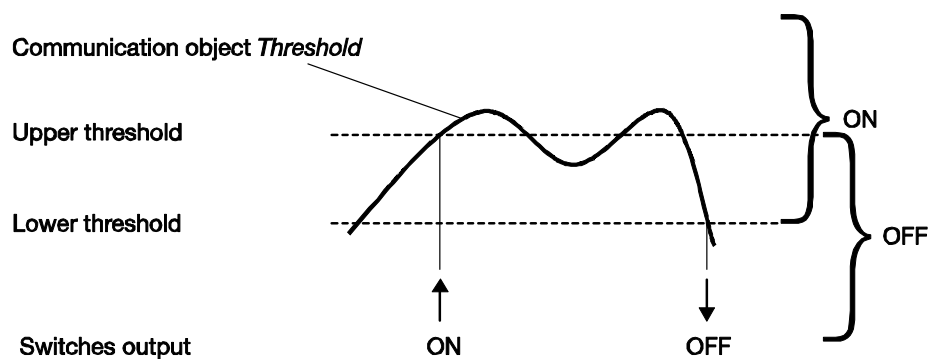

When the value exceeds the upper threshold or falls below the lower threshold, the output is switched.

Note

If the communication object *Threshold* value receives a value, which does not exceed or fall below any of the threshold values when compared to the old value, no switching operations are triggered.

During the function *Threshold*, the Switch Actuator can continue to receive telegrams that can trigger switching actions.

The communications object *Switch* as well as the functions scene, preset and threshold have the same priority and are processed in the order that the telegram is received.

Threshold values are not hysteresis values

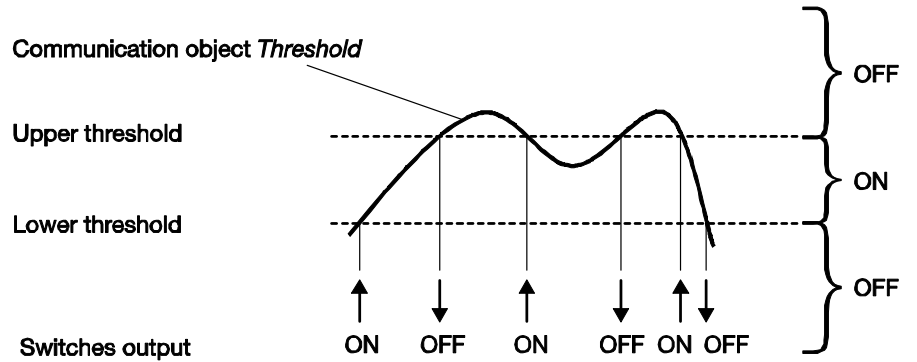

When the value exceeds or falls below any threshold value, the output is switched.

Note

If the communication object *Threshold* value receives a value, which does not exceed or fall below any of the threshold values when compared to the old value, no switching operations are triggered.

4.3 Operating mode *Heating Actuator*

4.3.1 Function chart

The following illustration indicates the sequence, in which the functions are processed:

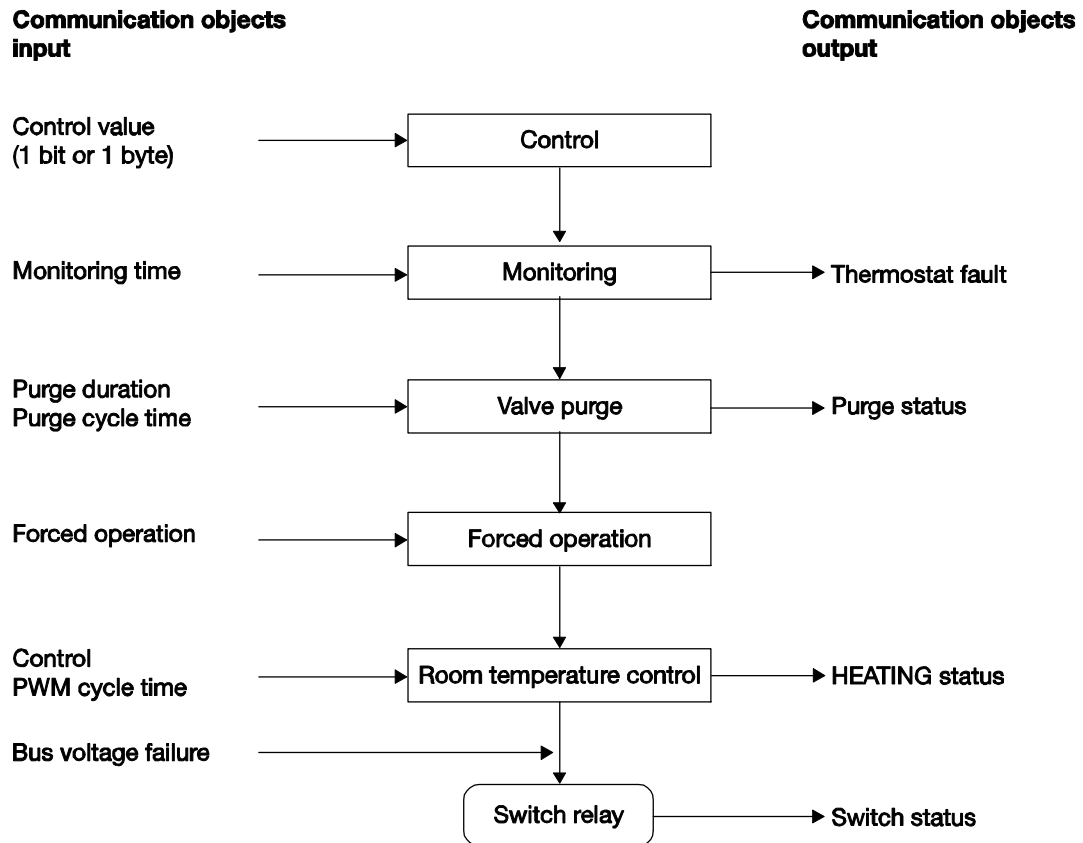

4.3.2 2 step control

2 step control is the simplest form of control. A control value is not calculated here. The room thermostat sends a 1 via the communication object *Switch* if a certain temperature is exceeded and a 0 if the value drops below a certain temperature. These switch values are implemented by the SA/S.

The room thermostat hysteresis limits can be used for control stability. Use of these limits does not effect the method of operation of the Switch Actuator.

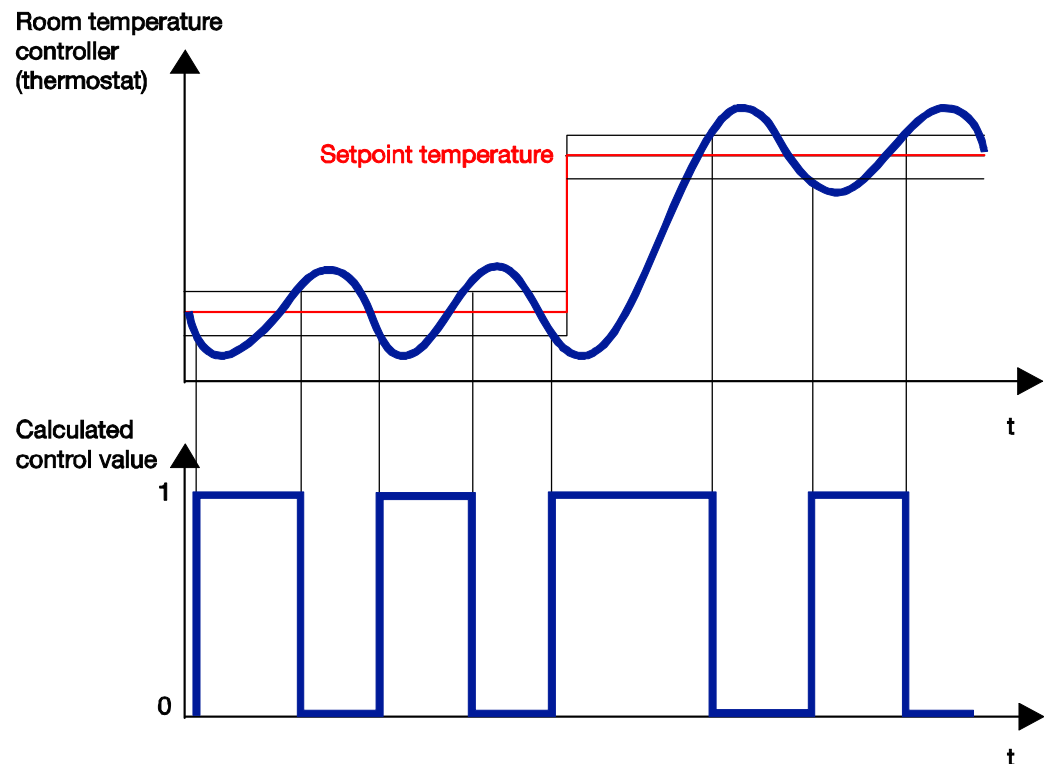

A room thermostat can use the control algorithm of a PWM control. As the room thermostat sends ON and OFF telegrams to the SA/S, the actuator operates like a 2 step control.

4.3.3 Pulse width modulation (PWM)

Should the SA/S receive a 1 byte control value as an input signal, it can use this value with the parameterised cycle time and undertake a PWM calculation.

With PWM control, the received control value (0...100 %) calculated in the control algorithm is converted to a pulse width modulation.

The conversion is based on a constant cycle time. If the SA/S, for example, receives a control value of 20 %, then for a cycle time of 15 minutes the valve will be opened for three minutes (20 % of 15 minutes) and closed for 12 minutes (80 % of 15 minutes).

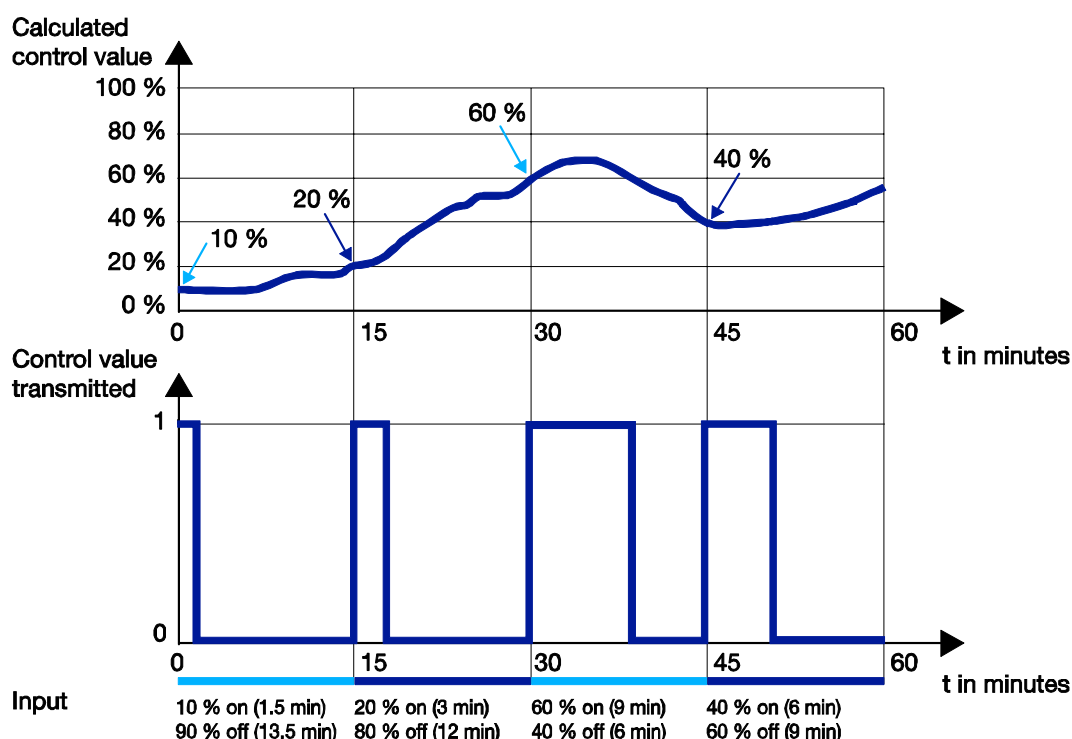

4.3.4 Pulse width modulation – calculation

With pulse width modulation, the control is implemented by a variable mark-space ratio.

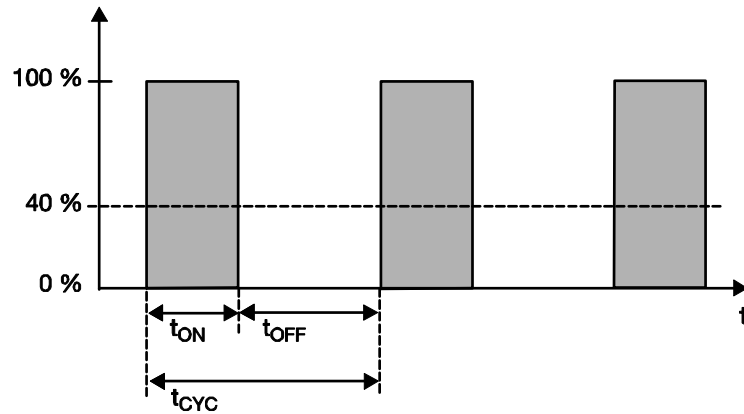

During the time t_{ON} the valve is opened, and during the time t_{OFF} it is closed. Due to $t_{ON} = 0.4 \times t_{CYC}$ the valve is set to about 40 % on. t_{CYC} is the so-called PWM cycle time for continuous control.

Note

Pulse width modulation leads to frequent switching of the outputs. The limited number of switching operations with normal Switch Actuators should be considered! The use of electronic Switch Actuators should be the preferred method.

4.3.5 Lifetime examination of a PWM control

If a PWM cycle time of 15 minutes has been selected, this means that 4 switching operations (switching on/off) occurs each hour, 96 in a day and 3000 in a month. This amounts to 36,000 switching operations a year. With a relay life of 10^5 switching operations, this means a Switch Actuator life of less than 3 years.

If however, the cycle time is set to just 3 minutes, this means in about 150,000 switching operations annually. This means the Switch Actuator life would be less than a year.

This observation assumes an AC1 switch loading (almost exclusively resistive load) at rated current. If the maximum number of switching operations for a purely mechanical relay loading is assumed, the life of the Switch Actuator is extended. This has an inherent risk: the contact materials can wear prematurely and cannot safely guarantee conduction of current.

In the following, conventional cycle times for control of various heating and air-condition systems are listed:

Heating system	Control type	Cycle time
Water heating Supply temperature 45...70 °C	PWM	15 minutes
Water heating Supply temperature < 45 °C	2 step PWM	– 15 minutes
Underfloor/wall heating	PWM	30...20 minutes
Electrical underfloor heating	PWM	30...20 minutes
Electrical fan heating	2 step	–
Electrical convection heating	PWM 2 step	10...15 minutes –

4.4 Behaviour with bus voltage failure, recovery and download

Reaction on bus voltage failure

The reaction of each individual output at bus voltage failure can be parameterized in parameter window *A: General* with the parameter *Reaction on bus voltage failure*. This parameterization acts directly on the relay and has the highest priority in the Switch Actuator.

For further information see: [Function chart, page 177](#) and [Function chart, page 192](#)

Before the first switching action is possible after bus voltage recovery, the SA/S will first store enough energy in order to ensure that enough energy is available to immediately bring all relays safely and immediately to the required (parameterised) position with a renewed bus voltage failure.

With the parameterization *Contact unchanged*, the relay contact at bus voltage failure is not changed, i.e. with the staircase lighting function operational, this light remains on until bus voltage recovery and until a new switch action is received.

After the contact positions are set with bus voltage recovery, the Switch Actuator remains non-functional until the bus voltage recovers.

Reaction on bus voltage recovery

The Switch Actuator draws the energy for switching the contact from the bus. After bus voltage is applied, sufficient energy is only available, depending on the SA/S type, after about 10...30 seconds to switch all contacts simultaneously, see [Technical data](#), page 7. Depending on the set transmission and switching delay after recovery of bus voltage set in the parameter window *General*, the individual outputs will only assume the contact positions that result from the function switching tree after this time. If a shorter time is set, the SA/S will only switch a first contact when sufficient energy is stored in the SA/S, in order to ensure that enough energy is available to immediately bring all outputs safely to the required switch state with a renewed bus voltage failure.

The Switch Actuator independently commences to operate after about 1 to 2 seconds, independently of the parameterised transmission and switching delay.

This means, the communication objects are set according to the programming, e.g. the timer for time delay is started. A switching action or a transmission of telegrams is only possible after the transmission and switch delay times have timed out.

The threshold, scene and preset values set via KNX are still available after bus voltage recovery, should the corresponding parameters for overwriting download be set to *no*.

With parameterization set to yes, the values set via the bus are overwritten with the values from the ETS.

Download:

The SA/S is not ready to function during a download. No telegrams are received or sent, and switch actions are not carried out. The primary objection is to ensure that a download has no effect on the operation of the device at the present time. Accordingly, it is possible to perform a download during normal operation.

In parameter window *A: General* with the parameters *Overwrite scene, preset and threshold value 1 with download*, you can choose whether the scenes and preset values stored in the SA/S are overwritten or retained using the parameterised values during a download.

In the following table, the behaviour of the Switch Actuator after bus voltage recovery, download and ETS bus reset are carried listed:

Behaviour with:	Bus voltage recovery	Download	ETS bus reset
Values of the communication objects	Generally, the values of the communication objects can be programmed. If not the communication object is written with 0.	Values are retained. Overwriting of the scene, preset and threshold 1 can be parameterised (X: General).	Values are retained including the scenes, preset values and threshold 1.
Timer	Are out of operation.	Values are retained and out of operation.	As the download
Contact setting	It is initially unknown. Changes by receipt of new results in dependence on the Function chart , page 177. Execution after the transmission and switch delay times have timed out (parameter window <i>General</i>).	Unchanged. The contact position is re-calculated in dependence on the object value only after an event is received, and with a resulting contact positioning it is set again. Exceptions are changes of the forced operation and safety priorities. These changes are checked immediately and undertaken if necessary.	As the download

Behaviour with:	Bus voltage recovery	Download	ETS bus reset
Operating mode Switch Actuator			
Switch object	Programmable ¹⁾ (Parameter window <i>X: General</i>)	Unchanged. Evaluation only after a new event has been received.	As the download
Function Time	Can be parameterised whether enabled (parameter window <i>X: Function</i>), timer out of operation.	Unchanged, timer out of operation.	As the download
Staircase light	In Parameter window <i>X: Function</i> , you can set if the functions <i>Time</i> are disabled or not disabled after bus voltage recovery. Otherwise unchanged. Change only after a new event has been received. The changed staircase lighting time set via the bus is lost and is replaced by the ETS programmed time.	Unchanged. Change only after an event has been received. e.g. the staircase lighting remains on until it is started again or switched off	As the download
Delays	Unchanged. Change only after an event has been received.	Unchanged. Change only after an event has been received.	As the download
Flashing	Unchanged. Change only after an event has been received.	Unchanged. Change only after an event has been received.	As the download
Permanent ON	Programmable (Parameter window <i>X: Time</i>)	unchanged	As the download
Preset/Scenes	The <i>Preset</i> and <i>Scene</i> values stored in the SA/S are restored, if the parameter overwrite at download has been set to <i>yes</i> . When parameterised to <i>no</i> , the values stored via KNX are retained.	Overwriting <i>Scene</i> and <i>Preset</i> values can be parameterised (parameter window <i>X: General</i>)	The stored <i>Preset</i> and <i>Scene</i> values in the SA/S are restored.
Logic (communication object <i>Logical connection x</i>)	Programmable (Parameter window <i>X: Logic</i>). Only evaluated after event.	Only evaluated after next event.	As the download
Threshold (communication object <i>Threshold input</i>)	Can be parameterised (parameter window <i>X: Threshold</i>). Only evaluated after next event.	Only evaluated after next event.	As the download

¹⁾ Before the initial download (device ex-works), the value before bus voltage failure is not defined. For this reason, the communication object *Switch* is written with 0 and the contact is opened, even though the default setting is set to *not write*.

Behaviour with:	Bus voltage recovery (BW)	Download	ETS bus reset
Threshold (communication object <i>Change Threshold value 1</i>)	The threshold value evaluation is carried out after bus voltage recovery using the parameterized threshold, whereby the last status threshold detected in operation is used for comparison. Should no Status Threshold exist before bus voltage failure, the factory set status (hysteresis limit undershoot) is assumed. The currently saved thresholds in the SA/S are overwritten with the values parameterised in the ETS, if the overwrite parameter at download is set to <i>yes</i> . When parameterised to <i>no</i> , the values stored via KNX are retained.	Overwrite Threshold 1 can be parameterised (parameter window <i>X: General</i>).	The Threshold 1 stored in the SA/S will be restored.
Safety Priorities	Inactive, values of the communication objects are set to <i>inactive</i>	Values of the communication objects are retained. Monitoring time will be restarted.	As the download
Safety Priorities	Inactive, values of the communication objects are set to <i>inactive</i>	Values of the communication objects are retained. Monitoring time will be restarted.	As the download
Forced operation	Programmable (Parameter window <i>X: Safety</i>)	Values of the communication objects are retained. Monitoring time will be restarted	As the download
Current detection	Current value is recalculated. Threshold Status is calculated using this.	Current value is recalculated. Threshold Status is calculated using this.	As the download
Operating mode Heating actuator			
Valve mode	Position programmable (parameter window <i>X: General</i>)	Calculation (PWM) is continued.	As the download
Function	Unchanged	Will be accepted, if changed	Unchanged
Monitoring (communication object <i>RTR fault</i>)	Monitoring time will be restarted. Value of communication object is 0.	Monitoring time will be restarted. Value of communication object is unchanged.	As the download
Behaviour forced operation	Off	Unchanged	As the download
Valve Purge	Monitoring time restarts.	Monitoring time restarts.	As the download

A Appendix**A.1 Scope of delivery**

The ABB i-bus® KNX Switch Actuator SA/S is supplied together with the following components.

Please check the items received using the following list.

- 1 pc. SA/S x.y.z.w¹⁾, MDRC
- 1 pc. installation and operating instructions
- 1 pc. bus connection terminal (red/black)

¹⁾ x = number of outputs (2, 4, 8 or 12)

y = rated current in Ampere (6 A, 10 A or 16 A)

z = device property:

- | | |
|---|--|
| 1 | = standard device with normal switching capacity |
| 5 | = C-Load device (200 µF) with increased switching capacity |
| 6 | = C-Load device (200 µF) with increased switching capacity and current detection |
| w | = hardware version |

A.2 Code table scene (8 bit)

The following table indicates the telegram code for an 8 bit scene in hexadecimal and binary code with the first 64 scenes. Normally when retrieving or storing a scene, an 8 bit value must be sent.

A.3 Ordering information

Device type	Product name	Order code	bbn 40 16779 EAN	Price group	Weight 1 pc. [kg]	Packaging [pc.]
6 A Switch Actuators for resistive, inductive or capacitive loads						
SA/S 4.6.1.1	Switch Actuator, 4-fold, 6 A, MDRC	2CDG 110 152 R0011	877862		0,18	1
SA/S 8.6.1.1	Switch Actuator, 8-fold, 6 A, MDRC	2CDG 110 153 R0011	877855		0,27	1
SA/S 12.6.1.1	Switch Actuator, 12-fold, 6 A, MDRC	2CDG 110 154 R0011	877848		0,35	1
10 A Switch Actuators for resistive, inductive or capacitive loads as well as fluorescent lamp loads (AX)						
SA/S 2.10.2.1	Switch Actuator, 2-fold, 10 A, MDRC	2CDG 110 155 R0011	877831		0,18	1
SA/S 4.10.2.1	Switch Actuator, 4-fold, 10 A, MDRC	2CDG 110 156 R0011	877824		0,29	1
SA/S 8.10.2.1	Switch Actuator, 8-fold, 10 A, MDRC	2CDG 110 157 R0011	877817		0,51	1
SA/S 12.10.2.1	Switch Actuator, 12-fold, 10 A, MDRC	2CDG 110 158 R0011	877800		0,74	1
16 A AC1 Switch Actuators for resistive loads						
SA/S 2.16.2.1	Switch Actuator, 2-fold, 16 A, MDRC	2CDG 110 159 R0011	877794		0,17	1
SA/S 4.16.2.1	Switch Actuator, 4-fold, 16 A, MDRC	2CDG 110 160 R0011	877787		0,29	1
SA/S 8.16.2.1	Switch Actuator, 8-fold, 16 A, MDRC	2CDG 110 161 R0011	877770		0,51	1
SA/S 12.16.2.1	Switch Actuator, 12-fold, 16 A, MDRC	2CDG 110 162 R0011	877763		0,67	1
16 A Switch Actuators for loads with high peak inrush currents, e.g. lighting equipment with compensation capacitors or fluorescent lamp loads (AX) to EN 60669, C-Laod without current detection						
SA/S 2.16.5.1	Switch Actuator, 2-fold, 16 A, MDRC	2CDG 110 132 R0011	70827 2		0,19	1
SA/S 4.16.5.1	Switch Actuator, 4-fold, 16 A, MDRC	2CDG 110 133 R0011	70828 9		0,31	1
SA/S 8.16.5.1	Switch Actuator, 8-fold, 16 A, MDRC	2CDG 110 134 R0011	70829 6		0,59	1
SA/S 12.16.5.1	Switch Actuator, 12-fold, 16 A, MDRC	2CDG 110 137 R0011	71107 4		0,80	1

Device type	Product name	Order code	bbn 40 16779 EAN	Price group	Weight 1 pc. [kg]	Packaging [pc.]
16/20 A Switch Actuators for loads with high peak inrush currents, e.g. lighting equipment with compensation capacitors or fluorescent lamp loads (AX) to EN 60669, C-Load with current detection						
SA/S 2.16.6.1	Switch Actuator, 2-fold, with current detection, 16 A, MDRC	2CDG 110 112 R0011	70830 2		0,2	1
SA/S 4.16.6.1	Switch Actuator, 4-fold, with current detection, 16 A, MDRC	2CDG 110 113 R0011	70831 9		0,38	1
SA/S 8.16.6.1	Switch Actuator, 8-fold, with current detection, 16 A, MDRC	2CDG 110 114 R0011	70832 6		0,69	1
SA/S 12.16.6.1	Switch Actuator, 12-fold, with current detection, 16 A, MDRC	2CDG 110 138 R0011	76516 9		0,90	1

A.5 Notes

A large grid area for taking notes, consisting of many small squares. The grid is empty and occupies most of the page below the section header.

Contact

ABB STOTZ-KONTAKT GmbH

Eppelheimer Strasse 82

69123 Heidelberg, Germany

Phone: +49 (0)6221 701 607

Fax: +49 (0)6221 701 724

e-mail: knx.marketing@de.abb.com

Further Information and Local Contacts:

www.abb.com/knx

Note:

We reserve the right to make technical changes or modify the contents of this document without prior notice. With regard to purchase orders, the agreed particulars shall prevail.

ABB AG does not accept any responsibility whatsoever for potential errors or possible lack of information in this document.

We reserve all rights in this document and in the subject matter and illustrations contained therein. Any reproduction, disclosure to third parties or utilization of its contents - in whole or in parts - is forbidden without prior written consent of ABB AG.

Copyright© 2011 ABB

All rights reserved