

### KNX-Sensor Temperature with (Tube-) Contacting Probe, SK01-T-ALTF 2

The KNX-sensor temperature SK01-T-xx with the Pt1000-probe ALTF2 is used for temperature detection of fluid or gaseous media in piping. The integrated KNX-Bus Coupler does not need additional auxiliary voltage. The temperature sensor is attached to the rear side of the terminal box enclosure. Installation on tubes is effected with an endless strap and metal tightener (included in the scope of delivery). The glass-globe-reinforced impact-resistant plastic casing contains the KNX-Bus components and the electronic measuring equipment. It comes with two quick-locking screws.

Several controllers are available in the application software (HVAC, Continuous, PWM) for the temperature. Additional functions include frost alarm, temperature limits, minimum/maximum value and update.

The sensor is configured with ETS (KNX Tool Software) and the application program. Controlling functions such as HVAC, switching threshold and various adjustment parameters are parameterized with ETS.



#### Application:

- Temperature detection on piping and tubes (coldwater or hot-water)
- Temperature detection on heating systems for system control

#### Areas of Application:

- Temperature detection on piping indoors/outdoors and in damp locations
- Decentralized heating regulation for constant KNX-Valves or electro-thermal valves
- Saves maximum and minimum values
- Room Temperature Controller with options Comfort/Standby/Night/Frost Protection
- Direct set point presetting and display of current set point via KNX-Bus
- Various disable options for the controller

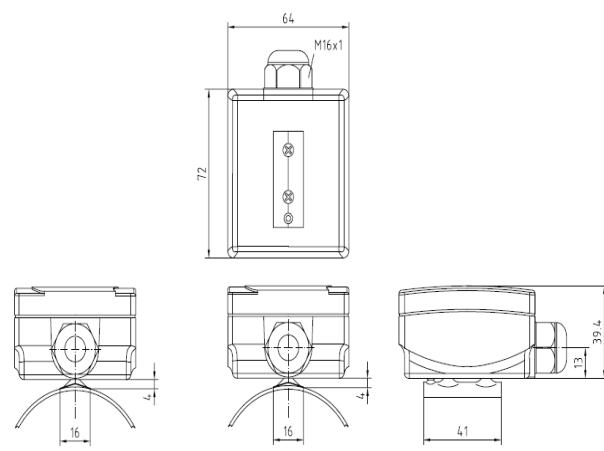
<p>Probe:          Tube Contacting Probe Temperature</p> <p>Probe Description:          Temperature probe PT1000 with  <b>Cu-Surface, high long term stability</b></p> <p>Sensor Application:          Installation on tubes with endless strap and metal tightener (included in the scope of delivery).          Strap dimensions: <math>\varnothing=13-92</math> mm (1 / 4 - 3"), 300 mm</p> <p>Temperature Range:       -30 ...+110 °C</p> <p>Protection:                 IP65</p>	
---	--

Technische Daten	SK01-T-ALTF2
Measurement:	Temperature
Temperature Controller HVAC Modi:	HVAC with increase/decrease options HVAC with relative set point adjustment HVAC with absolute set point adjustment
Temperature Controller Options:	Comfort Temperature, Stand-by Temperature Night Temperature, Frost Protection Temperature
Temperature Controller Controller Output:	Continuous / Switching PI-Controller / Two-Position Controller with hysteresis
Temperature Controller HVAC-Display:	HVAC-Status Byte, HVAC-Status-Bits
Limit Alarm (Upper/Lower):	Temperature
Minimum/Maximum Temperature:	Saved minimum/maximum actual temperature
Frost Protection Alarm:	Falling below frost protection temperature
Update:	Temperature
Adjustment Parameters:	Offset adjustment, Output Inversion
Lock and Reset Objects:	Minimum/Maximum Temperature
Send Options:	Do Not Send, Periodic Sending by Adjustments
Temperature Probe:	PT1000 combined with pipe surface (CU)
Environment Temperature:	Storage -20...+100°C, Operating -20...+80°C (transducer)
Environment Humidity:	0...95% rH, not condensating
Temperature Range:	-30...+110 °C
Accuracy of Temperature:	+/- 0,5 °C
Temperature Resolution:	+/- 0,01 °C
Operating Voltage:	EIB/KNX Bus voltage 24 V DC
Power Consumption ca.:	10 mA bei 24V DC
Auxiliary Supply:	not necessary
Bus Coupler:	integrated
Start-up with ETS:	ARC_TFK.VD2 Produkt: <b>Sensor Temperatur IP65</b>
Circuit Points:	EIB-2-pol clamp (red/black)
Protection:	IP65
Fittings:	Installation with endless strap and metal tightener
Casing:	white plastic
Measurements Casing:	72 mm x 64 mm x 39,4 mm (W x H x D)
Article Number:	<b>30101006</b>

Optional Available:			
<b>ALTF 2 Pt1000</b>		<b>KNX-Sensor Temperature with Contacting/Tube Contacting Probe</b>	
SK01-T-ALTF 2 Pt1000		-30...+110°C	<b>30101006</b>

**Start-up:**

The KNX Sensor is set up using the ETS (KNX Tool Software) and the applicable application program. The sensor is delivered unprogrammed. All functions are programmed and parameterized with ETS. Please read the ETS instructions.

**Installation:**

SK01-T-E-xx sensors are for outdoor use and for (moist) indoor areas. They fulfill protection class IP65. The sensor is fitted onto the wall with two screws. The tube contacting probe is affixed to the tube with a tightening strap.

For mounting position see below.

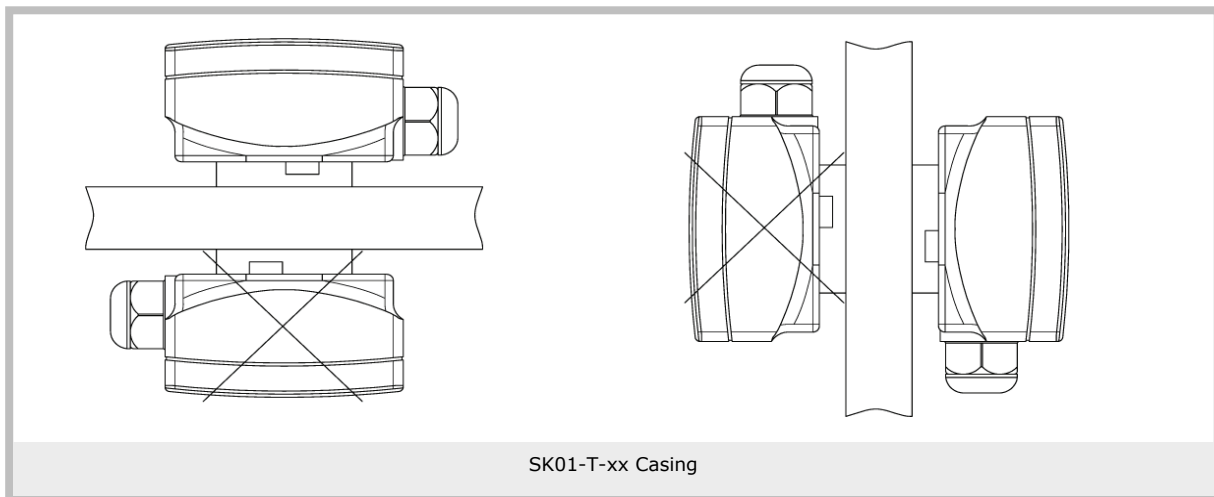

The lid can be opened to a 90° angle by loosening the screws.

The cable for the external temperature sensor (PT 1000) can be detached from the terminal block. When reattaching, it is not necessary to pay attention to the polarity of clamps 1 and 2. After the sensor has been mounted onto the wall or ceiling, lead the KNX bus cable through the hole in the casing (PK screw connection). Remove the bus clamps from the device and connect the cable to it. Place the bus clamps back onto the device. After programming the device, place the lid back on by twisting the screws 90°.

→ Be careful not to damage the electronics during the installation process.

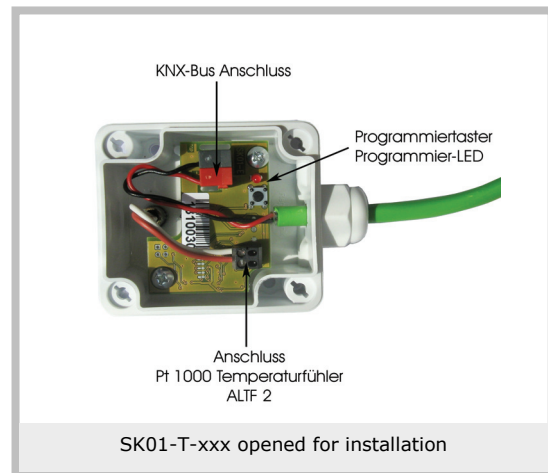

**In case of bus line voltage restoration (voltage outage):**

All temperature defaults on the KNX/EIB bus are restored. After a line voltage restoration the temperature data is rounded up or down to 0.5°C of the actual value. The controller and outputs start with their current values. The HVAC mode byte is set to 0. ETS Parameter adjustments are restored.

**Program de-activate and reset sensor:**

If there is an error in programming and the sensor no longer reacts, you can delete the project by pressing the program button. Press the program button down while connecting the EIB bus clamp and wait for the program LED to light up. This takes from 5-10 seconds.

**Imprint:**

Publisher: Arcus-EDS GmbH, Kreuziger Straße 14-15, 10247 Berlin

Responsible for Content: Hjalmar Hevers, Reinhard Pegelow

Reprints, including partial reprints, can be made only with expressed permission from Arcus-EDS GmbH. This information is the best to our knowledge and is without guarantee. We reserve the right to make any technical and price changes at any time.

**Liability:**

Selection and determining the appropriateness of the devices for a designated purpose is the customer's full responsibility. We offer no liability or guarantee for this. The data in the catalogue and data sheets is a result of experienced measurements and does not embody a guarantee of particular features. Arcus excludes responsibility for damage done on the part of the customer due to improper operation/projecting or malfunctions. On the contrary, the operator/projector must ensure that improper operation, and projection and malfunctions do not lead to any further damage.

**Safety Guidelines:**

Attention! Installing and assembling electrical devices must only be done by an electronics specialist. The customer should be aware of and adhere to the safety guidelines of VDE, TÜV and the appropriate energy provider. Our guarantee does not include defects and damage caused by improper use or non-compliance of operating instructions.

**Warranty:**

We provide a warranty as required by law. Please contact us in case of malfunction and send the device with a full description of the fault to the address below

**Manufacturer:**



**Registered Trademarks:**



The CE Trademark is an unofficial market trademark used exclusively by authorities and provides no warranty of properties.



Registered Trademark of Konnex Association