



Configuration Manual

Contents

1. Introduction.....	3
1.1 About EAE Technology	3
1.2 About Valesa Touch Panel.....	3
1.3 Brief Overview of the System.....	4
1.4 Communication Protocols in the System	4
1.5 Configuration Logic and Terminologies.....	5
2. Network Configurations	5
2.1 IP Configuration of Site Server	5
2.1.1 Site Server User Interface.....	5
2.1.2 Putty	6
2.2 Project import into Site Server	10
2.3 SIP Configuration of Site Server and Valesa Panels.....	11
3. Smarthome Configuration Software	13
3.1 Site management & Security & Concierge	14
3.2 Cameras.....	15
3.3 Block	15
3.4 Apartment	16
3.3.1 Safety.....	16
3.3.2 Alarm	17
3.3.3 Logic.....	18
3.4 Rooms.....	19
3.4.1 Lighting.....	20
3.4.2 Blind.....	22
3.4.3 Conditioning	23
3.4.4 General Control	24
3.5 Intercom	24
4. Configuring 3 rd party devices.....	25
4.1 Cameras.....	25
4.2 Intercoms.....	25
4.2.1 Example configuration.....	26
4.3 IP Telephones	29
4.3.1 Example configuration.....	29
5. Importing project into Touch Panel	32

5.1 Remote project import to Valesa	32
5.2 Local project import to Valesa.....	33
6. Example project.....	35
6.1 Overview of the project.....	35
6.2 Creating the Project.....	37
6.3 Configuring 3 rd party devices.....	38
6.4 Configuring Site SIP Server	38
6.5 Configuring Valesa Settings.....	39
6.6 Connecting 3 rd party devices to Valesa	40
6.6.1 Site Management	40
6.6.2 Cameras.....	41
6.6.3 Concierge.....	41
6.6.4 Security.....	42
6.6.5 Intercom	42
6.7 Configuring Apartment Type.....	43
6.7.1 Safety.....	43
6.7.2 Alarms.....	43
6.7.3 Logic.....	46
6.8 Creating Rooms	47
6.8.1 Lighting	47
6.8.2 Blind.....	49
6.8.3 Conditioning	50
6.8.4 General Control	50
7.0 Summary.....	51

PREFACE

This is the configuration guide for Valesa Touch Panel. The information in this document may be modified without notice and EAE Technology Co. assumes no commitments.

© 2018 EAE Technology. All Rights Reserved.

Valesa Touch Panel, Valesa logo, software graphics, button icons are trade products and commercial offerings of EAE Technology Co.

Any other trademarks in this guide belong to their respective owners.

1. Introduction

EAE Group which has distributors and authorized dealers in 95 countries is a leading manufacturer of electrical products in Turkey with more than 2.500 employees worldwide. EAE Technologies is established as a member of EAE Group to create and provide pioneering hardware and software products and complete system solutions for building automation and management. Our vision is to transform the current building automation industry via cutting-edge user interface design and powerful backend algorithms.

1.1 About EAE Technology

We believe that creating energy efficient buildings having comfortable atmosphere must be much simpler and affordable than traditional solutions. We will always provide expandable and interoperable solutions, fully customizable to customer's real needs and wants, avoiding proprietary, disconnected and closed system solutions.

As EAE Technology, we develop value added solutions for international markets in our R&D center. We continue to develop innovative products in smart home and buildings industry, and deliver all our products in accordance with international, open standards such as KNX, DALI, TCP/IP and WiFi.

To this end, we are proud to introduce building management system, Hyperion visualization & control software and our basic line of KNX & DALI devices to the World, bringing technology of the future to the building infrastructure, software and field equipment.

1.2 About Valesa Touch Panel

Valesa Touch Panel is a product in EAE Technology Inita product range with a purpose of monitoring and controlling various smart home applications. Some features include communicating with Intercom, cameras and concierge services. Valesa Touch Panel has an 11.6" Full HD LG touch screen. Elegant design with a thickness of only 10mm, Valesa offers a total of 8 isolated digital inputs and outputs. Note that there are two versions of Valesa, with or without relay outputs. For more information please refer to www.eaetechnology.com.

1.3 Brief Overview of the System

Typical application diagram is shown on the right diagram. SIP server is crucial for communicating with various devices such as Intercom and VOIP phones. Only devices conforming and featuring the technical standards of SIP protocol will work as expected with Valesa Touch Panel. Internet connection makes sure Valesa can receive updates on weather forecast, traffic status and foreign exchange market. Also, Valesa touch panel needs internet connection for remote controls of Valesa Mobile unless it is controlled through the same local home network.

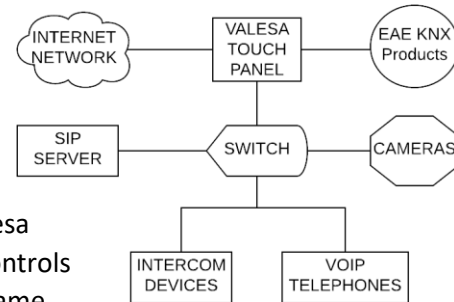

1.4 Communication Protocols in the System

For the various parts of the system to work as intended, the network infrastructure must include an SIP Server. An SIP server is the main component of an IP PBX and manages SIP calls in the network. All the intercom devices, Valesa, IP telephones and many more use SIP network as a communication layer. EAE Technology offers a high-quality SIP Server as a system provider. There are two ways to proceed configuring the system. First, you can assign an SIP ID to each device through their configuration interfaces and then configure the SIP Server by entering each device's SIP ID. Second would be to assign SIP ID to each device on the SIP Server and then assign corresponding SIP IDs to each device. Either way the system will work as intended.

Valesa communicates with blind controllers, lighting equipment, heating-cooling systems through KNX protocol. KNX devices can manage lighting, blinds and shutters, HVAC, security systems, energy management, audio video, white goods, displays, remote control, etc. Valesa Touch Panel offers an on-device KNX port for a direct connection to KNX line providing a flexible environment and endless monitoring & controlling opportunities for anyone willing to extend the power of KNX with Valesa Touch Panel.

1.5 Configuration Logic and Terminologies

The logic behind the software contains creating an SIP network, apartment types, blocks and apartment units itself. Block is an apartment building. Flat or an apartment is single apartment unit inside a block. Site would be a living area containing many blocks. As an example, a block may have 10 stories and 4 apartments at each story.

While using the software, you will need to create a project. Next step would be to create apartment type profiles. You may have different apartments with different number of rooms. Once you create apartment types, you will need to configure the SIP server.

Usually SIP server is powerful enough to manage a site. However, if there are more than one SIP server, you will need to create more than one project. Configuration of SIP server is explained in the next section. Once you are done configuring SIP server, you can create a Block and specify the number of apartments (flats).

Creating a block and apartments is straightforward. You will need to pick an apartment type and specify the IP address and the SIP number for the touch panel to be used in that apartment.

TP Inputs are relay contacts on the touch panel.

Other configurations need not only an effort on the software side but the device side. You may need to reach each device's configuration interface and specify IP and SIP addresses individually. For more information on this step, please refer section 4.

2. Network Configurations

2.1 IP Configuration of Site Server

Default site server IP address: 192.168.0.100

If you want to change the IP address of the site server there are two options: Logging in to Site Server User Interface or using Putty software.

2.1.1 Site Server User Interface

SIP server inside site server is programmed to start automatically once the computer is connected to power. Once the SIP server is up and running login to the user interface of the site server. You can access user interface by typing **IPaddressofSIPServer:9099** to browser (192.168.0.100:9099).

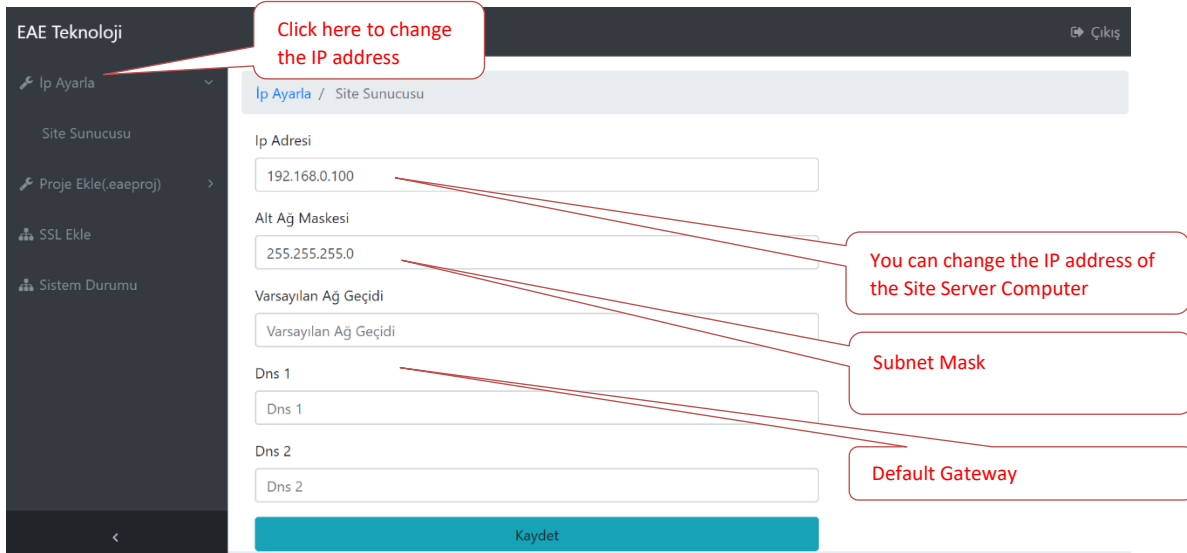
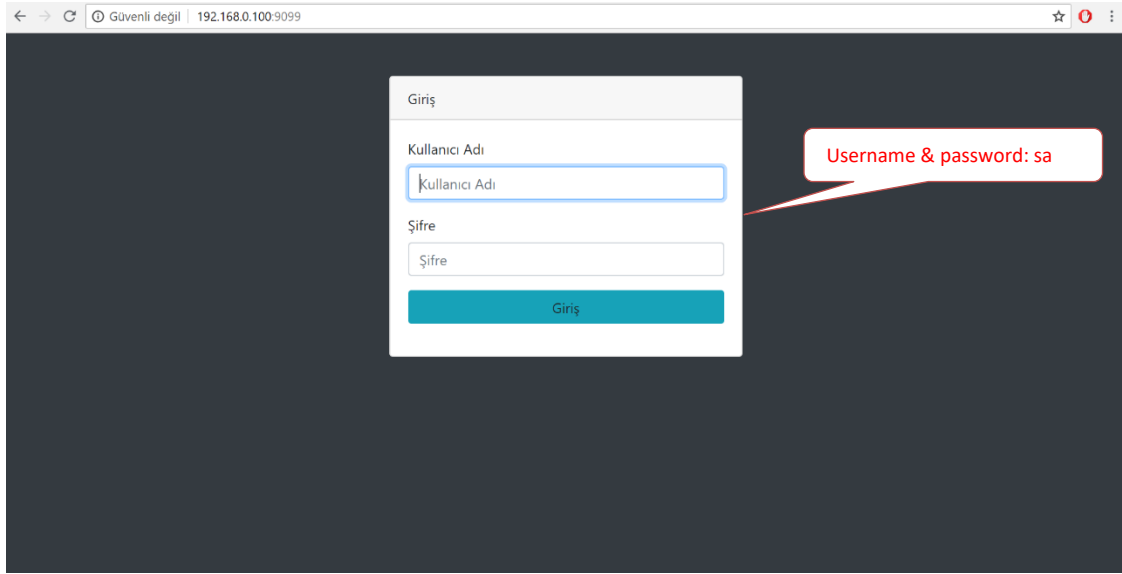

2.1.2 Putty

Download Putty (SSH and telnet client) to your computer to connect to site server.

Download link:

<https://www.chiark.greenend.org.uk/~sgtatham/putty/latest.html>

Open Putty and write the IP address of site server to “Host Name” section. Click open.

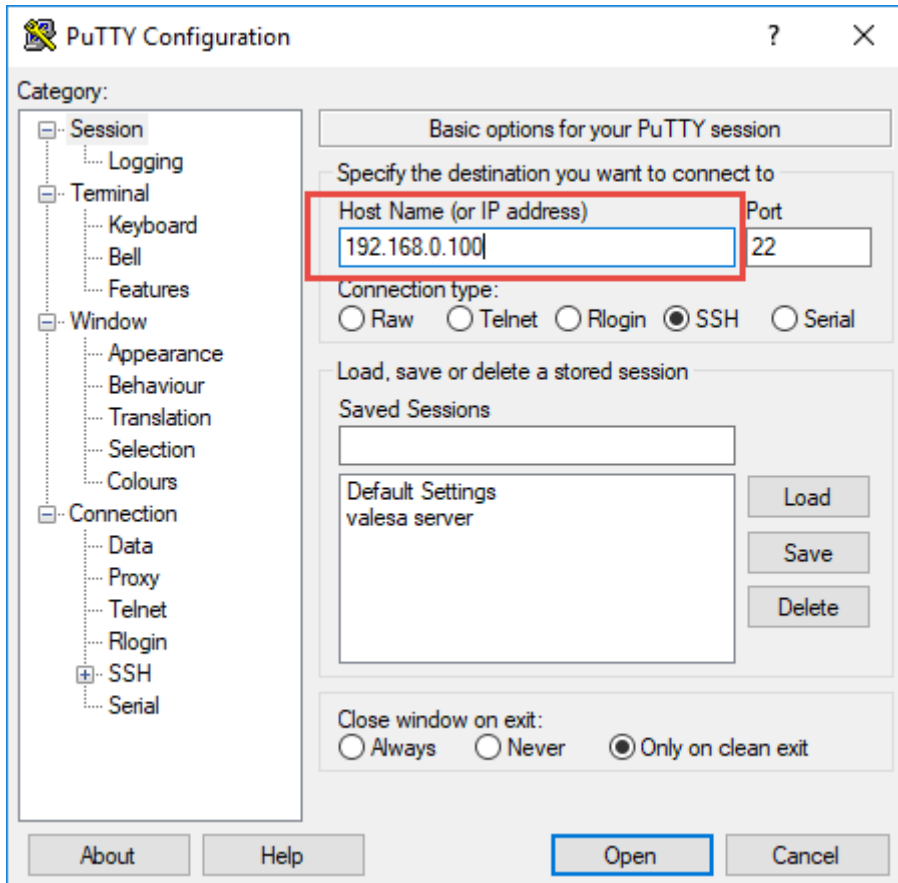

Username: admin01

Password: enerji2014*

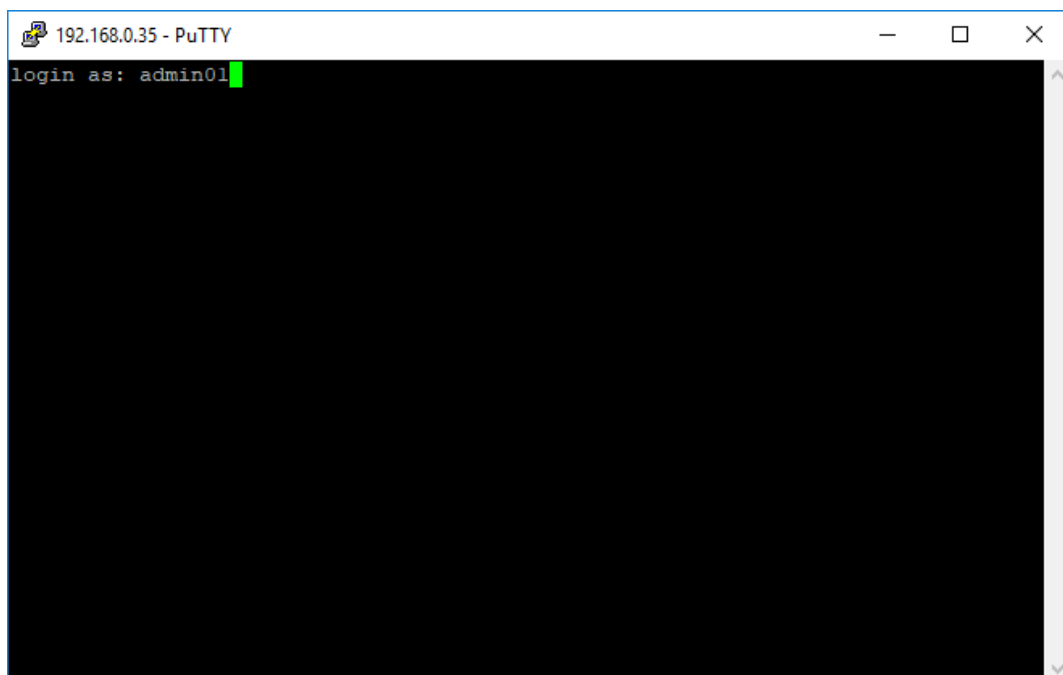

LOGIN SCREEN

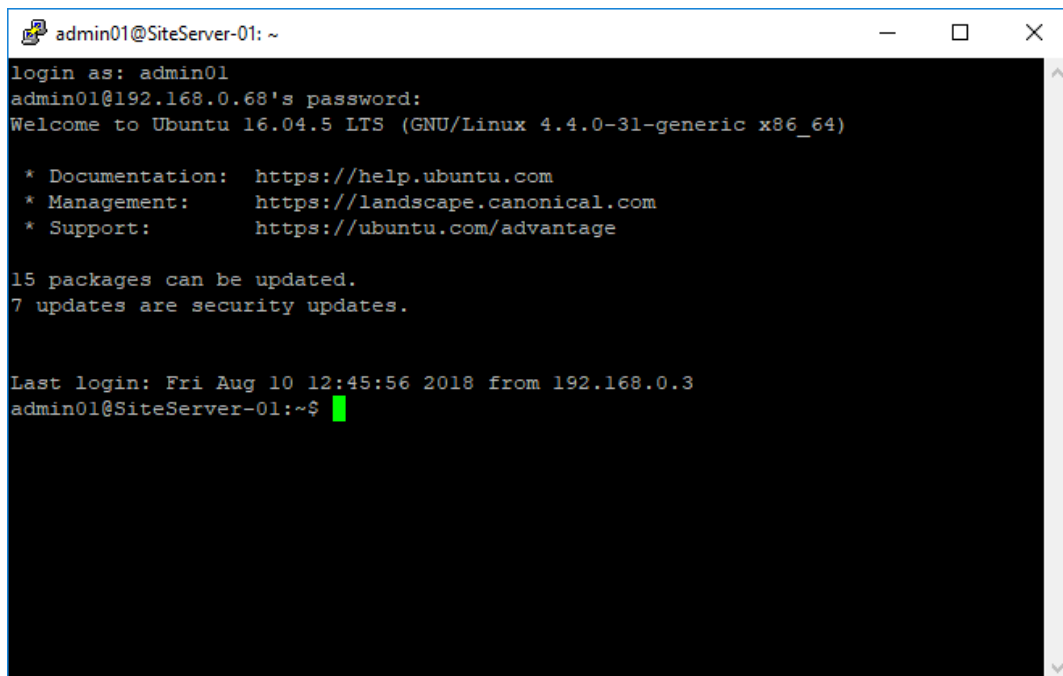

```
admin01@SiteServer-01: ~
login as: admin01
admin01@192.168.0.68's password:
Welcome to Ubuntu 16.04.5 LTS (GNU/Linux 4.4.0-31-generic x86_64)

 * Documentation:  https://help.ubuntu.com
 * Management:    https://landscape.canonical.com
 * Support:       https://ubuntu.com/advantage

15 packages can be updated.
7 updates are security updates.

Last login: Fri Aug 10 12:45:56 2018 from 192.168.0.3
admin01@SiteServer-01:~$
```

AFTER LOGIN

Write following command to command prompt and enter:

```
sudo nano /etc/network/interfaces
```

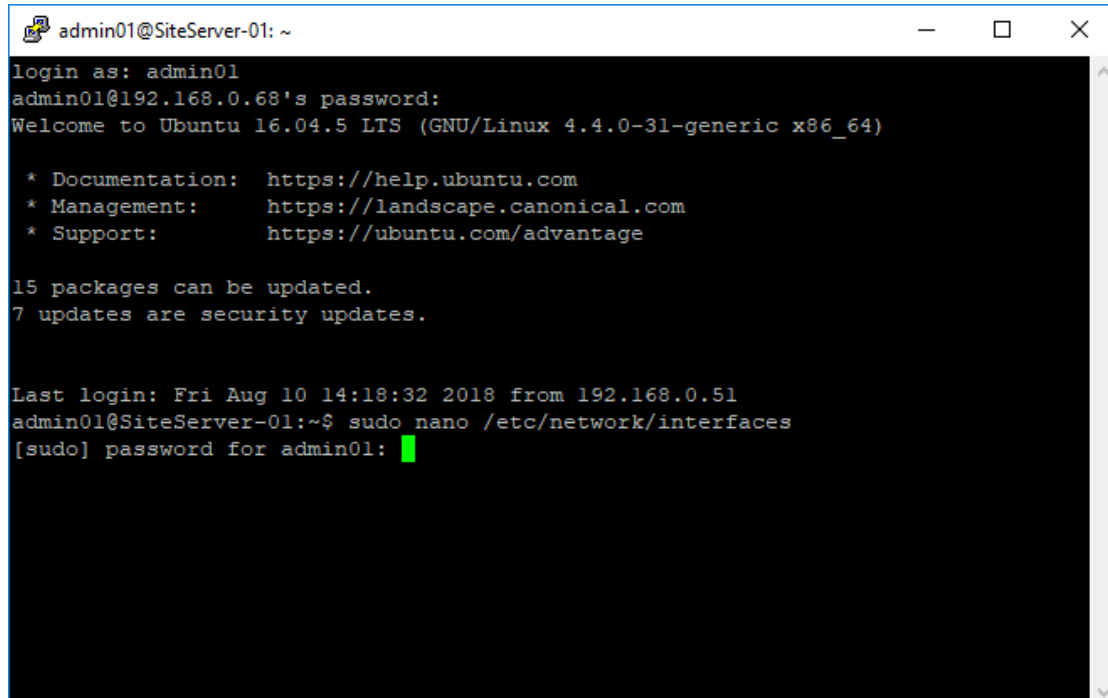

```
admin01@SiteServer-01: ~
login as: admin01
admin01@192.168.0.68's password:
Welcome to Ubuntu 16.04.5 LTS (GNU/Linux 4.4.0-31-generic x86_64)

 * Documentation:  https://help.ubuntu.com
 * Management:    https://landscape.canonical.com
 * Support:       https://ubuntu.com/advantage

15 packages can be updated.
7 updates are security updates.

Last login: Fri Aug 10 14:18:32 2018 from 192.168.0.51
admin01@SiteServer-01:~$ sudo nano /etc/network/interfaces
[sudo] password for admin01:
```

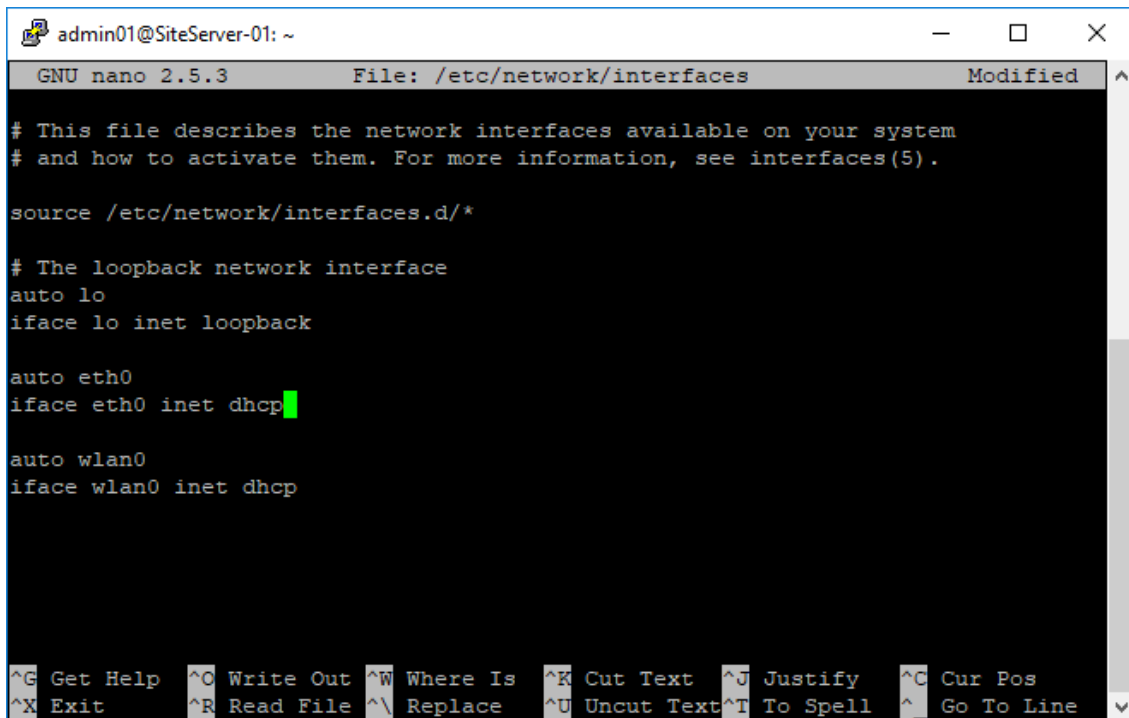

```
admin01@SiteServer-01: ~
GNU nano 2.5.3 File: /etc/network/interfaces Modified
# This file describes the network interfaces available on your system
# and how to activate them. For more information, see interfaces(5).

source /etc/network/interfaces.d/*

# The loopback network interface
auto lo
iface lo inet loopback

auto eth0
iface eth0 inet dhcp

auto wlan0
iface wlan0 inet dhcp

^G Get Help ^O Write Out ^W Where Is ^K Cut Text ^J Justify ^C Cur Pos
^X Exit ^R Read File ^\ Replace ^U Uncut Text ^T To Spell ^_ Go To Line
```

Write the following ip settings as shown in screenshot below. “Ctrl+X” and “Yes” enter.

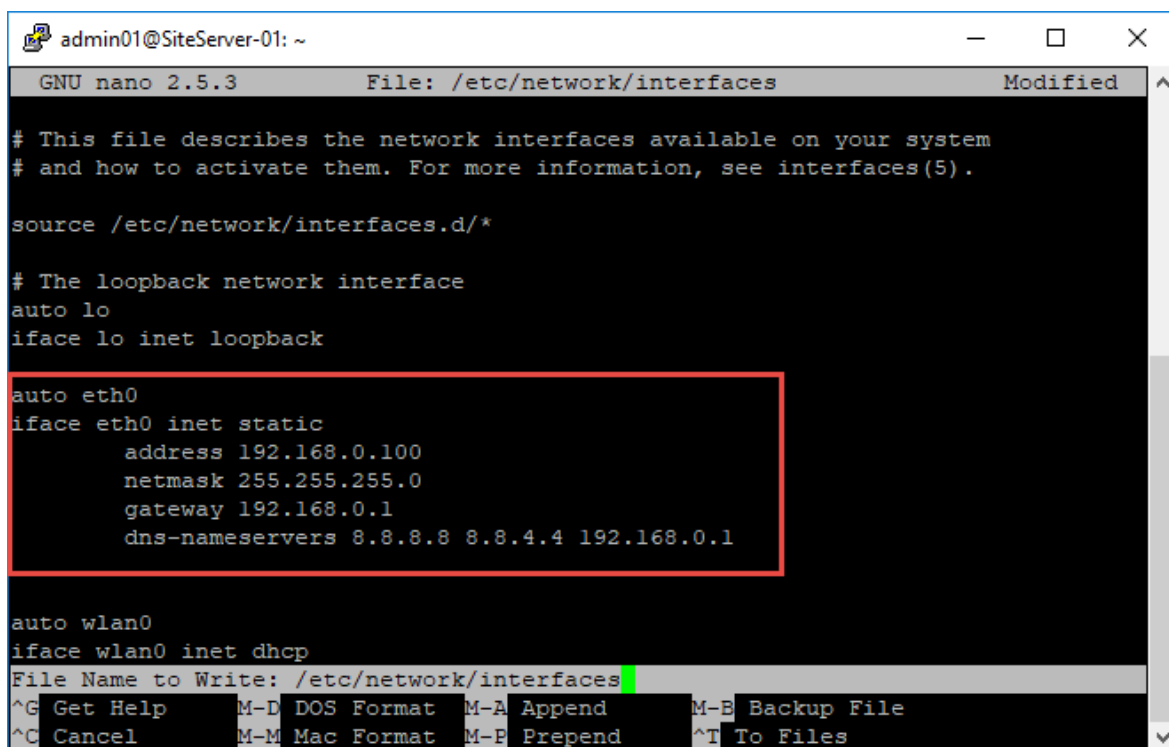

```
admin01@SiteServer-01: ~
GNU nano 2.5.3 File: /etc/network/interfaces Modified
# This file describes the network interfaces available on your system
# and how to activate them. For more information, see interfaces(5).

source /etc/network/interfaces.d/*

# The loopback network interface
auto lo
iface lo inet loopback

auto eth0
iface eth0 inet static
    address 192.168.0.100
    netmask 255.255.255.0
    gateway 192.168.0.1
    dns-nameservers 8.8.8.8 8.8.4.4 192.168.0.1

auto wlan0
iface wlan0 inet dhcp
File Name to Write: /etc/network/interfaces
^G Get Help M-D DOS Format M-A Append M-B Backup File
^C Cancel M-M Mac Format M-E Prepend ^T To Files
```

Please restart the site server with following command:

```
sudo reboot
```

You may login again and check the IP settings you have made with command “ifconfig”.

2.2 Project import into Site Server

One copy of the project file (.eaeproj) needs to be imported into site server.

This step is crucial for the system to work properly.

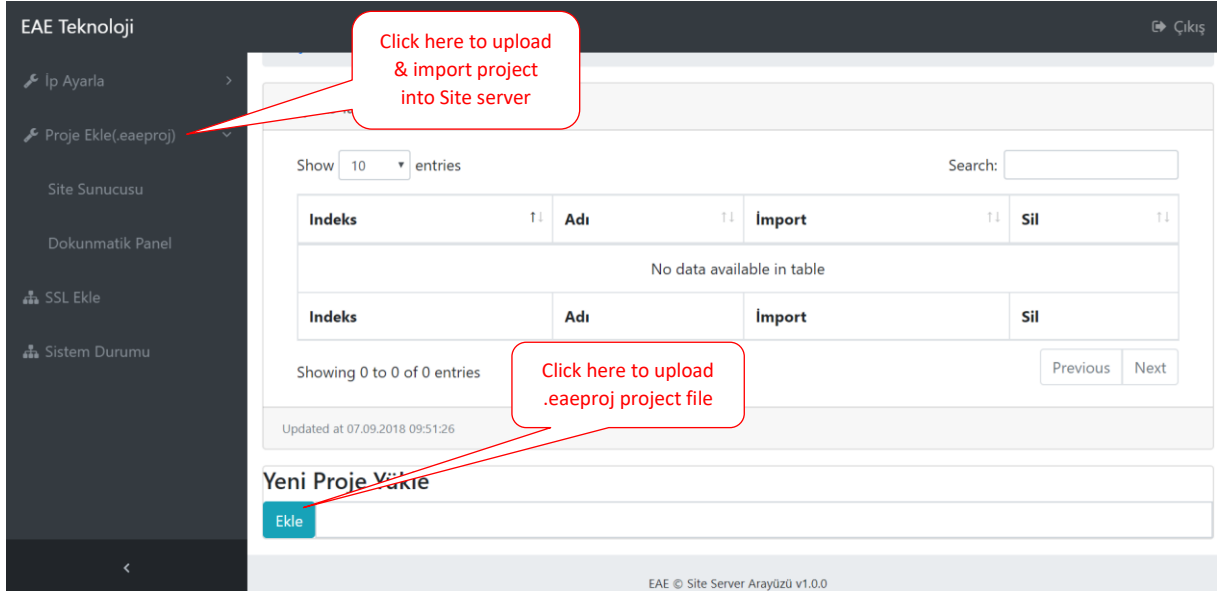

EAE Teknoloji

İp Ayarla >

Proje Ekle(eaeproj) >

Site Sunucusu

Dokunmatik Panel

SSL Ekle

Sistem Durumu

Show 10 entries

Search:

İndeks	Adı	İmport	Sil
No data available in table			
İndeks	Adı	İmport	Sil

Showing 0 to 0 of 0 entries

Previous Next

Updated at 07.09.2018 09:51:26

Yeni Proje Yükle

Ekle

EAE © Site Server Arayüzü v1.0.0

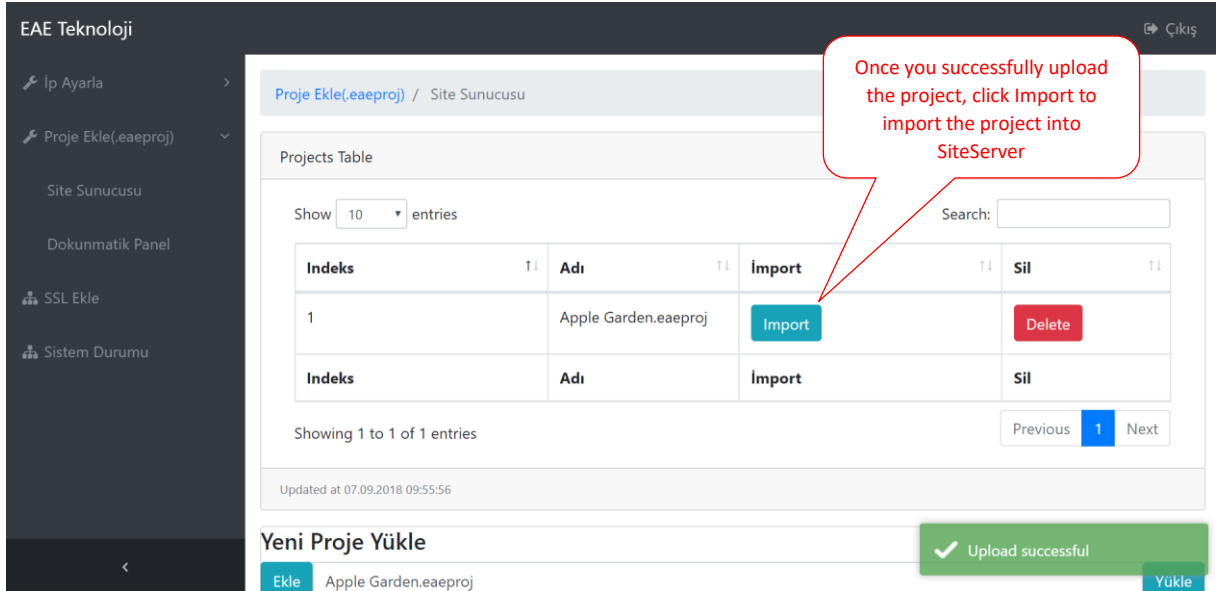

EAE Teknoloji

İp Ayarla >

Proje Ekle(eaeproj) >

Site Sunucusu

Dokunmatik Panel

SSL Ekle

Sistem Durumu

Proje Ekle(eaeproj) / Site Sunucusu

Projects Table

Show 10 entries

Search:

İndeks	Adı	İmport	Sil
1	Apple Garden.eaeproj	Import	Delete
İndeks	Adı	İmport	Sil

Showing 1 to 1 of 1 entries

Previous 1 Next

Updated at 07.09.2018 09:55:56

Yeni Proje Yükle

Ekle Apple Garden.eaeproj

Upload successful

Yükle

2.3 SIP Configuration of Site Server and Valesa Panels

Once the SIP server is up and running login to the user interface of the Brekeke software. You can access user interface by typing **IPaddressofSIPServer:8080/sip** to browser (192.168.0.100:8080/sip).

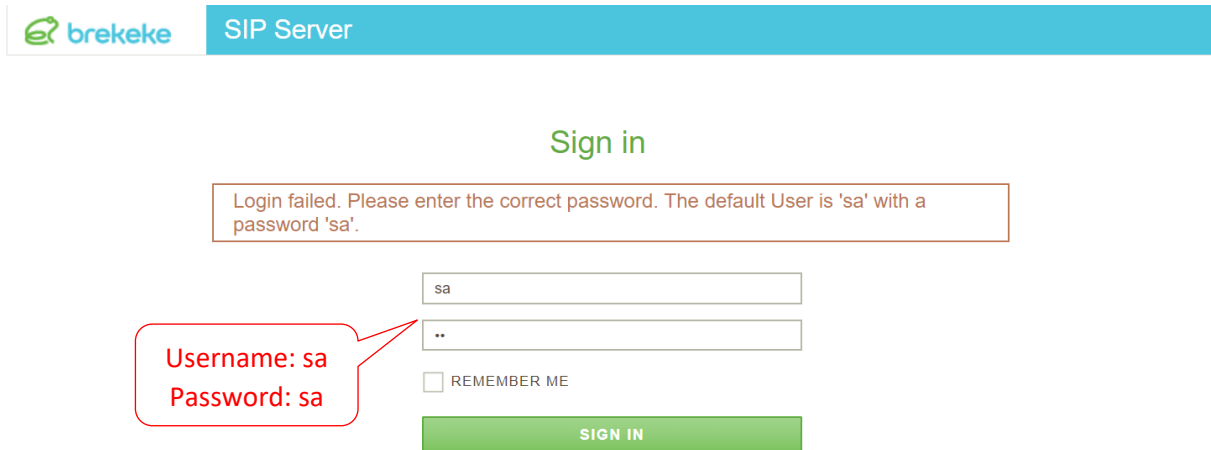

Once you are logged in, if you click on SYSTEM -> Status from the left side, you can find all details about the system.

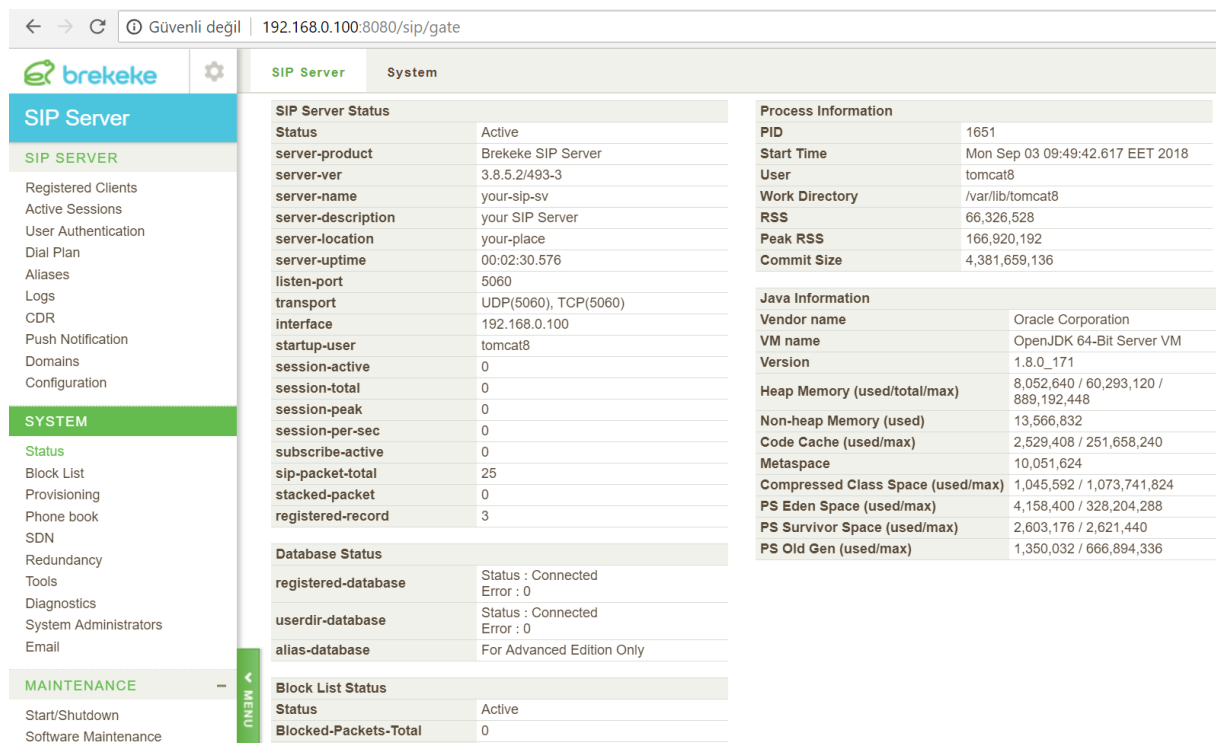

Click on the User Authentication section and add a new user. “User” must be the SIP ID you will give or have already given to the devices on the network. For more information refer section 1.4. “Password” is PINcodeXXX where XXX is the SIP ID you have given to the device (i.e. PINcode100). Click “Add”. In the screenshots below an example of an Akuvox Intercom device with an SIP ID of 100 is shown but the configuration is the same for all of the devices to be used in your SIP network.

SIP server Side:

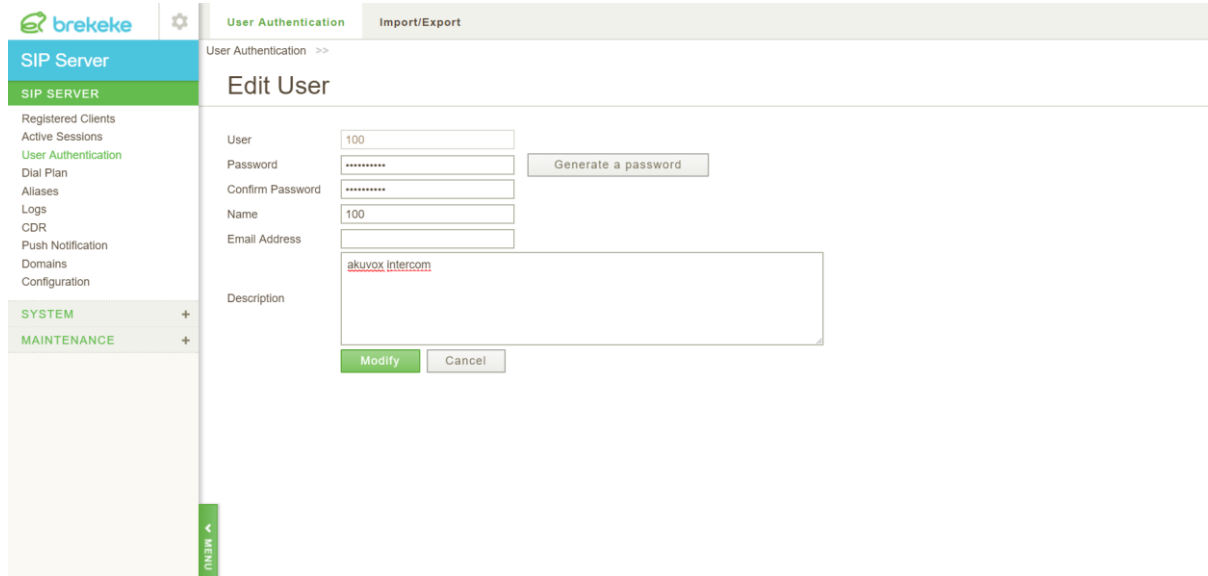

Click on the Registered Clients section. If device side configuration is done correctly, device should appear on the list after a few minutes. If not restart the SIP Server from MAINTENANCE -> Start/Shutdown -> Restart. If you still don't see device(s) as registered, either the device(s) hasn't been configured yet or device configuration is not right.

User should display the SIP ID you have given to the intercom.

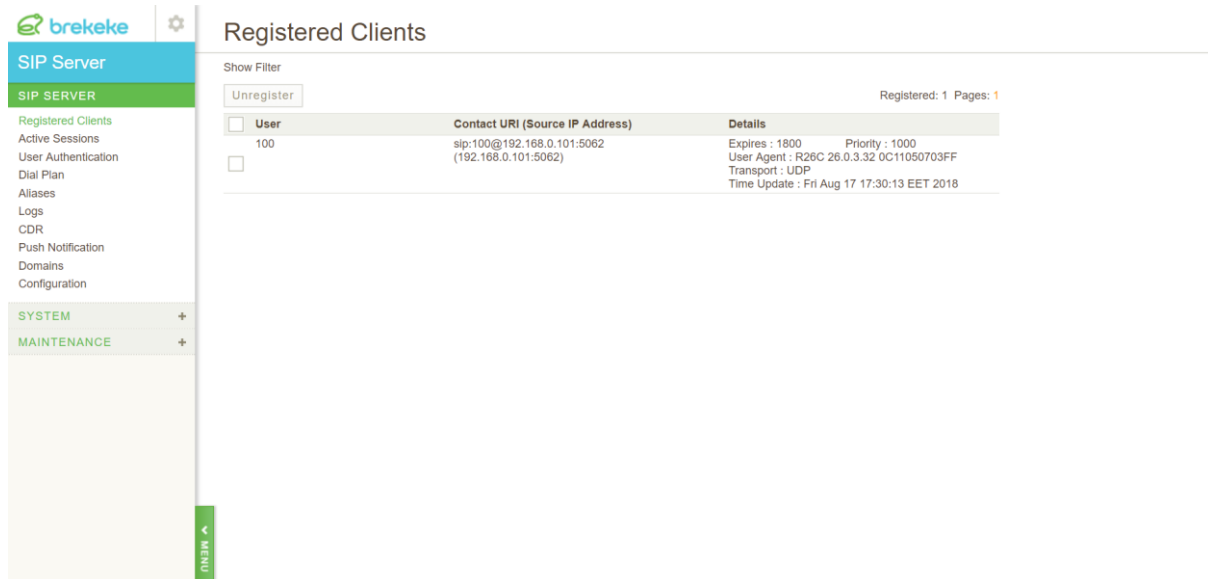

User	Contact URI (Source IP Address)	Details
<input type="checkbox"/> 100	sip:100@192.168.0.101:5062 (192.168.0.101:5062)	Expires : 1800 Priority : 1000 User Agent : R26C 26.0.3.32 0C11050703FF Transport : UDP Time Update : Fri Aug 17 17:30:13 EET 2018

3. Smarthome Configuration Software

Open “Smarthome Configuration” windows application. Create a new project.
Apply the steps described below one by one and avoid skipping any step.

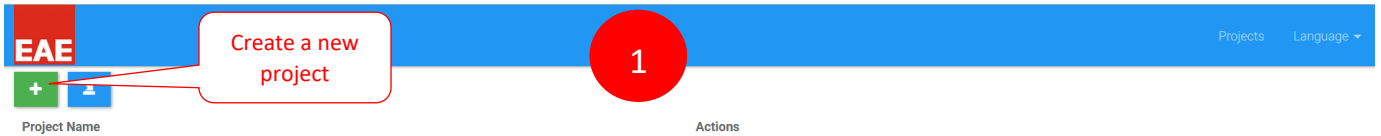

Click Settings tab and follow the steps below.

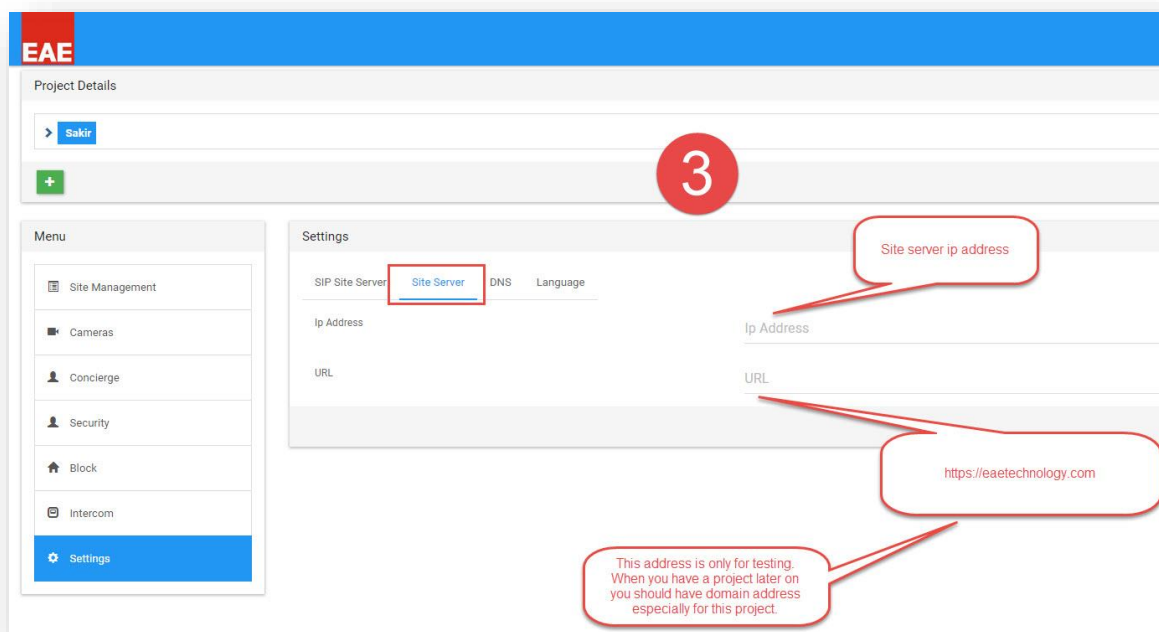
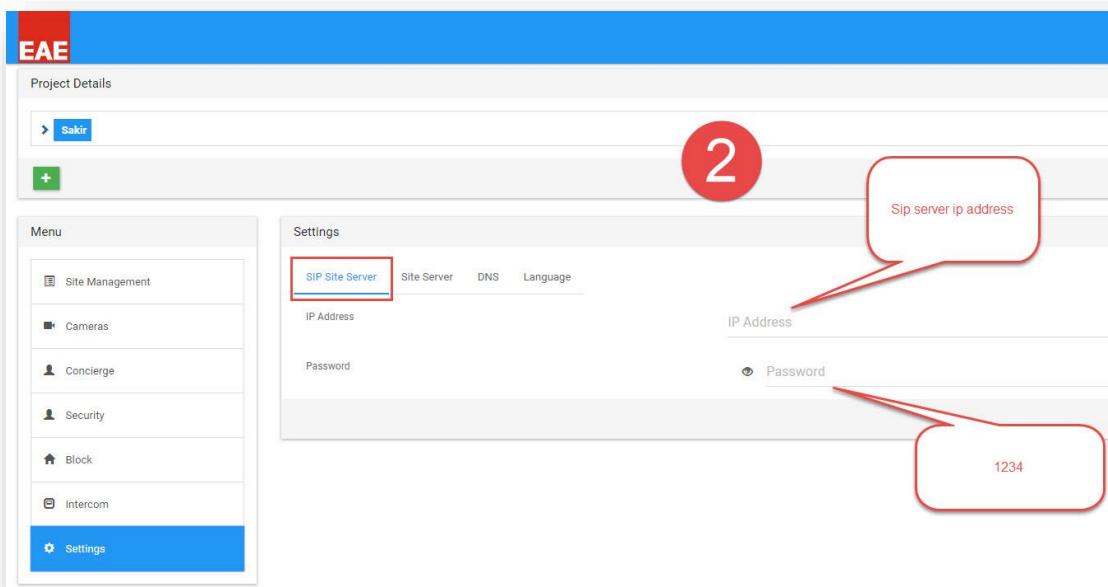

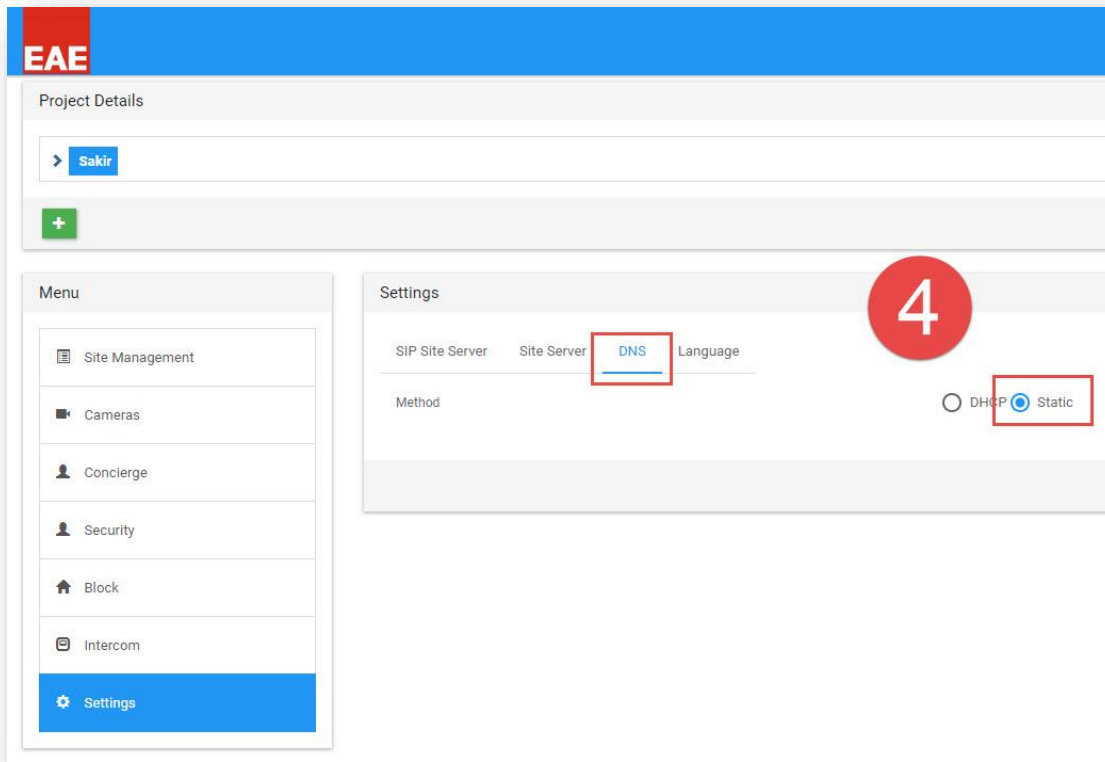

3.1 Site management & Security & Concierge

Site managers, security personnel and people responsible for concierge services are given a software to communicate with residents through touch panels. This software has its own SIP ID and is used to send/receive messages to/from residents. In addition, calls can be made to these services with this software. For the concierge section, any service box you check in the configuration section will make it available on the screen. Other parts of configuration are the same for all three.

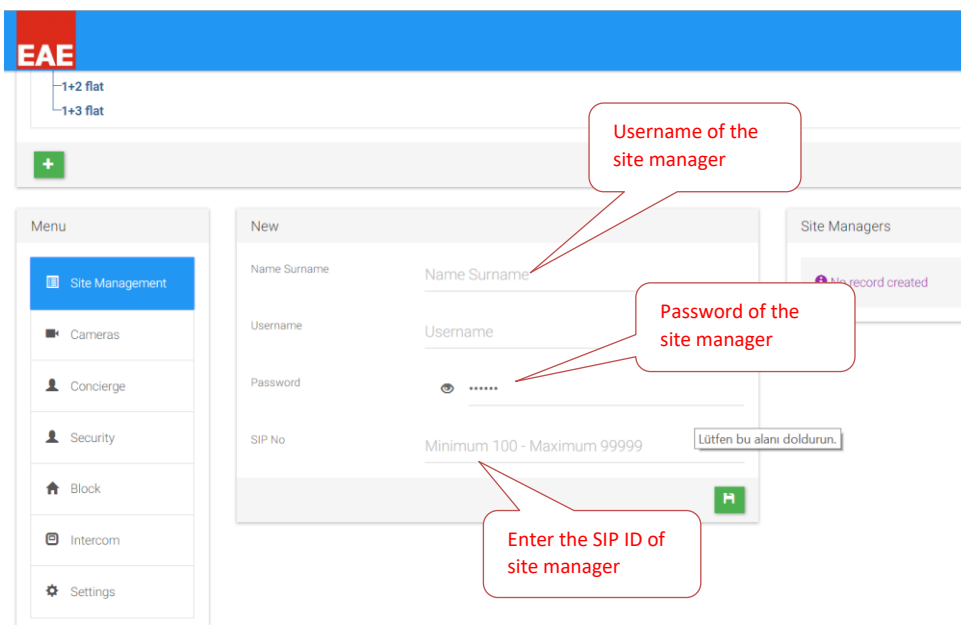

3.2 Cameras

You can add cameras to the touch panel either through an NVR device or directly from the network. To find out rtsp url of cameras on an NVR, refer to NVR documentation. Also, different camera brands may have different rtsp URL structures. Cameras to be added to the touch panel need rtsp stream capability with h264 codec. You may need to configure the cameras to enable these features.

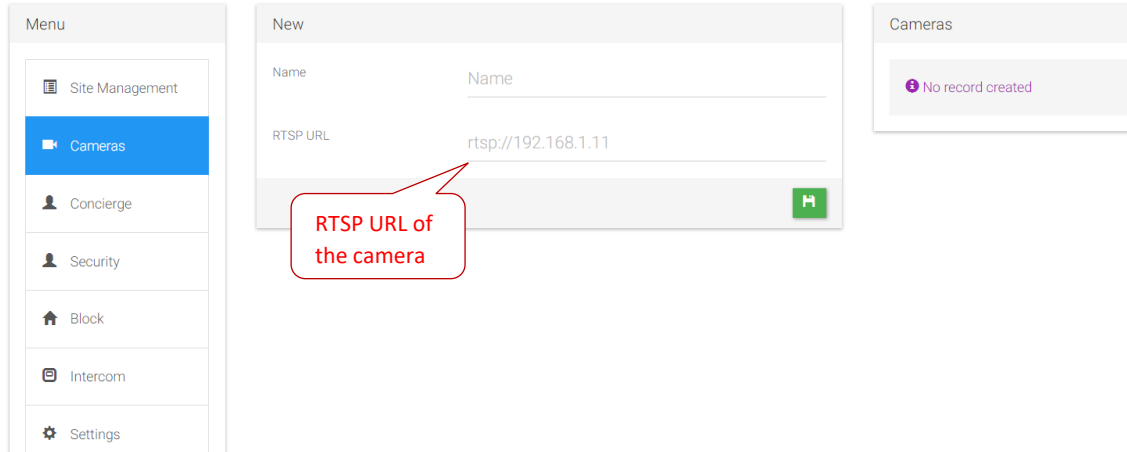

3.3 Block

Click on the Block tab and create Block for the project. More information about Blocks at section 1.5.

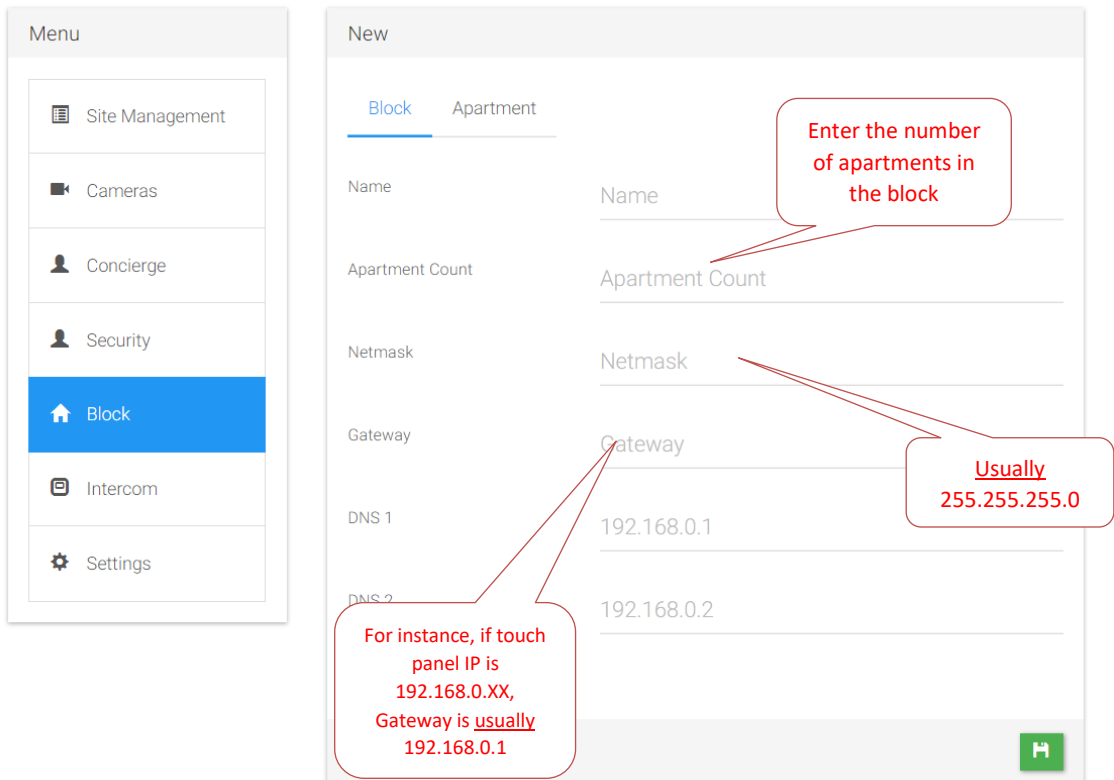

3.4 Apartment

To add apartments into the blocks apartment types should be defined.

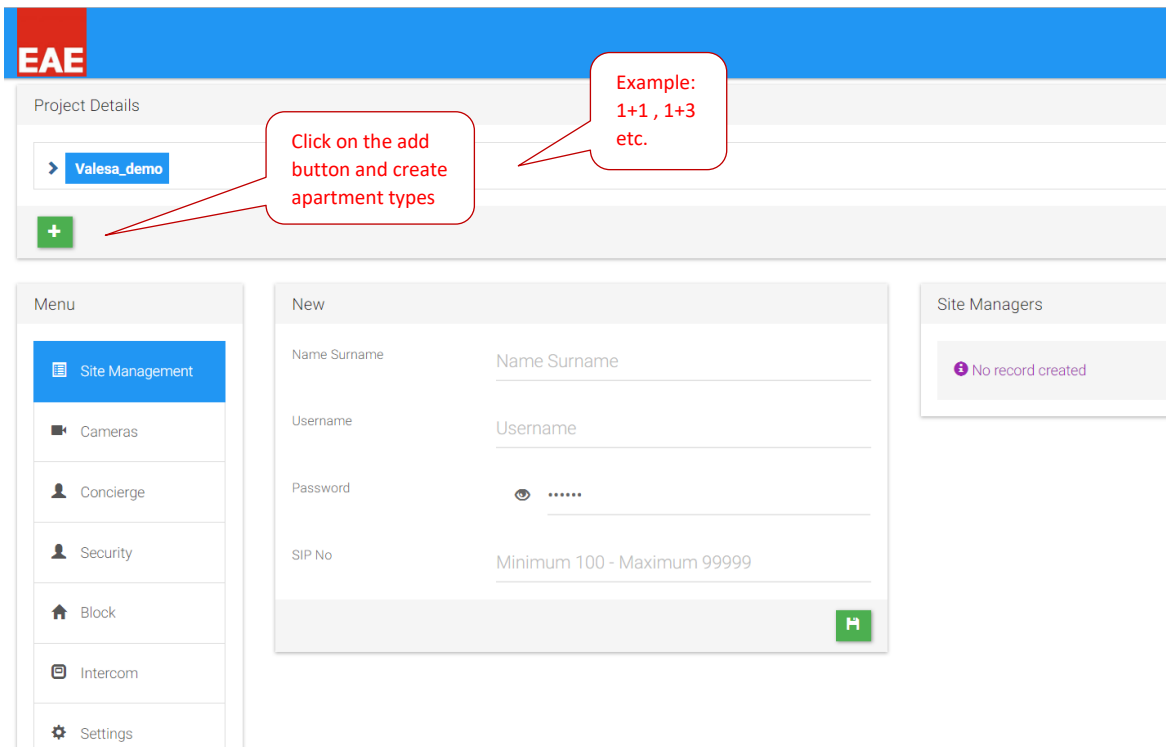

Click on an apartment type you have just created. You will be taken to a configuration page consisting Safety, Alarm and Logic.

3.3.1 Safety

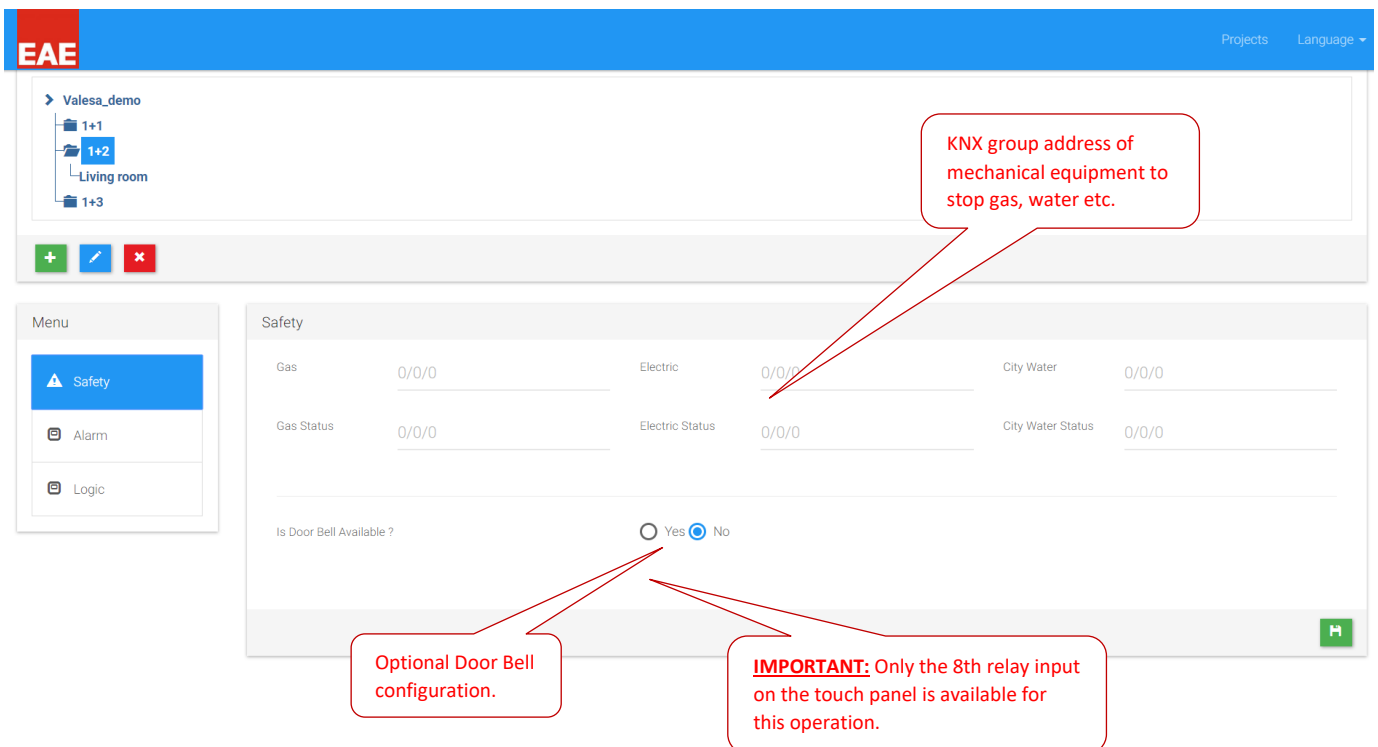

3.3.2 Alarm

Alarms can be configured in two ways: KNX-based alarms and Contact alarms.

KNX alarm occurs through KNX port and touch panel may control other interfaces according to the alarm.

Contact alarm occurs through relays on the panel and again touch panel can control other interfaces.

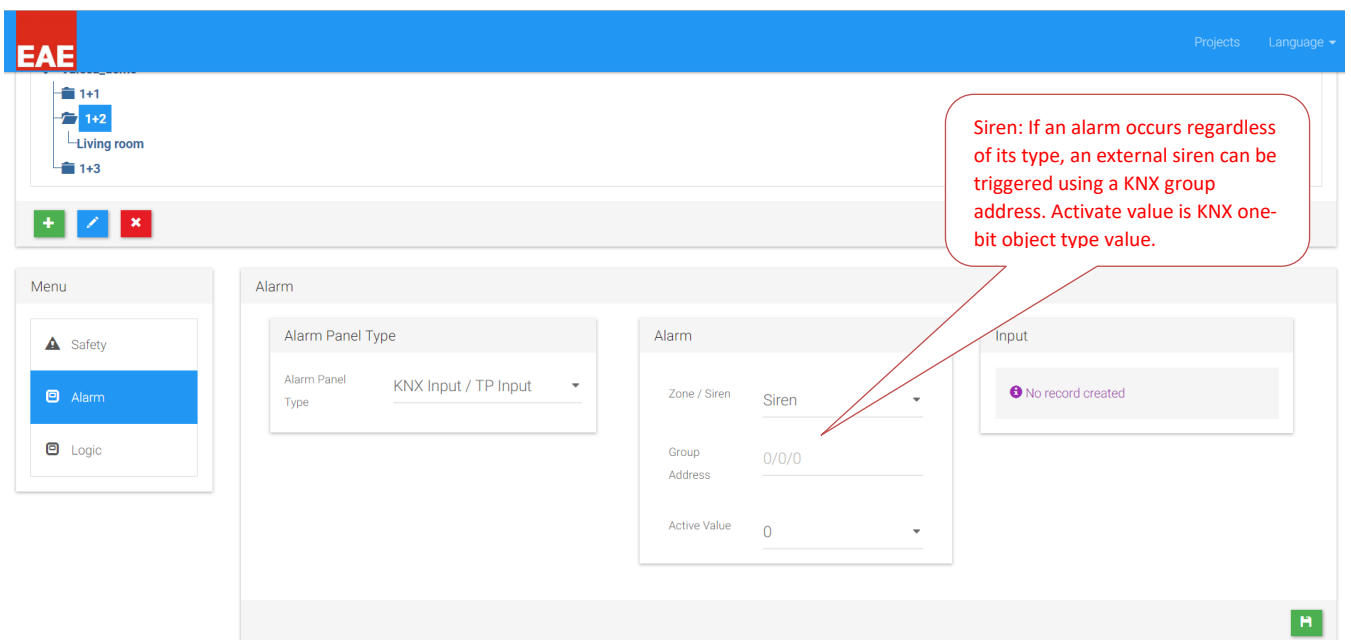
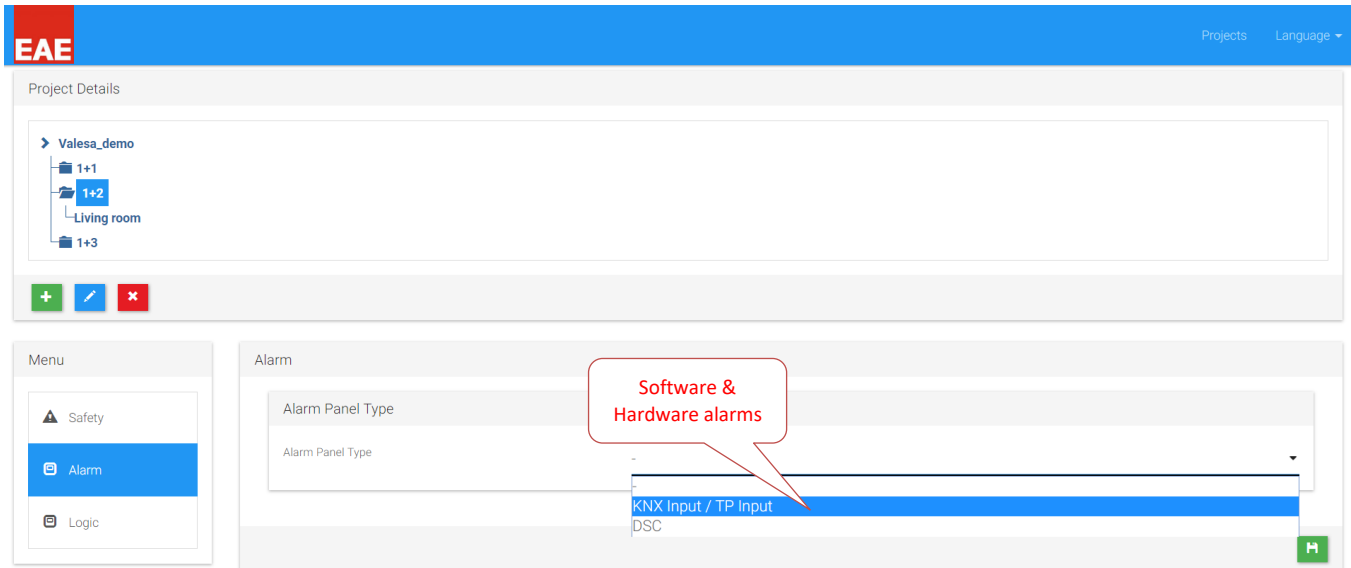

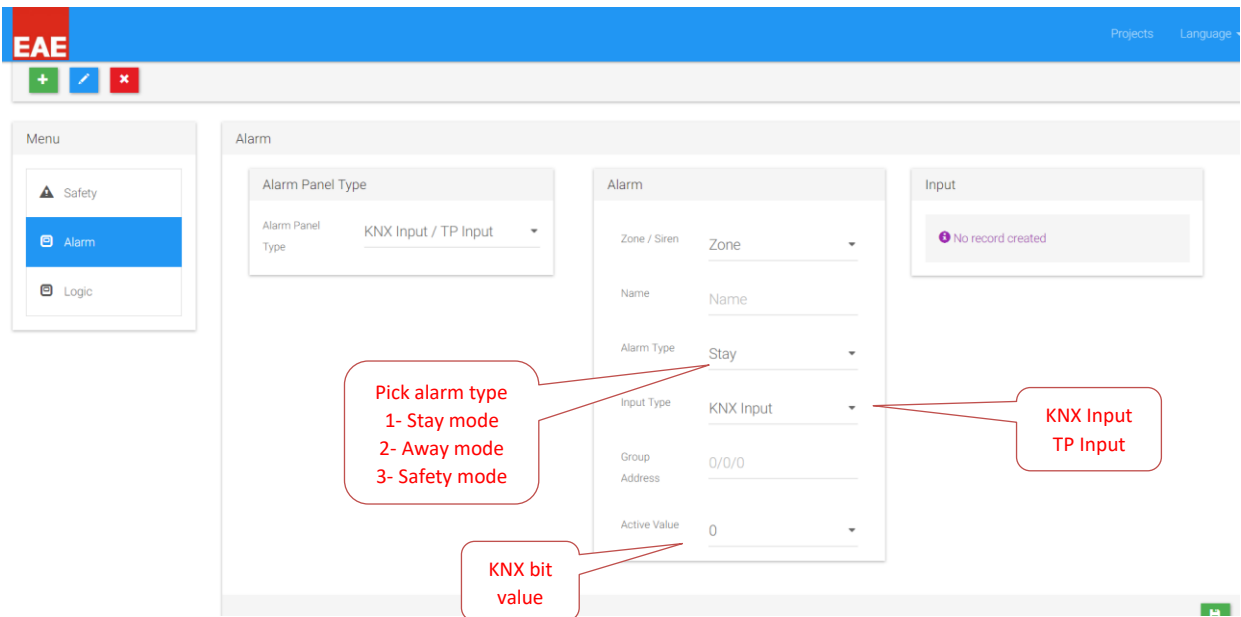

Zone: Area of the alarm such as living room, corridor etc.

Pick alarm type:

- 1- Stay mode: Alarm mode used when resident is home. Window contacts, door contacts or any device to be activated when resident is home.
- 2- Away mode: Alarm mode used when resident is away. Any device that is activated in Stay Mode, plus other devices such as PIR detectors.
- 3- Safety mode: Sensors such as smoke detectors, flood detectors or any other safety device is added with this option.

KNX Input – KNX based alarm input option

TP Input – contact alarm input type option (input relays on the touch panel)

3.3.3 Logic

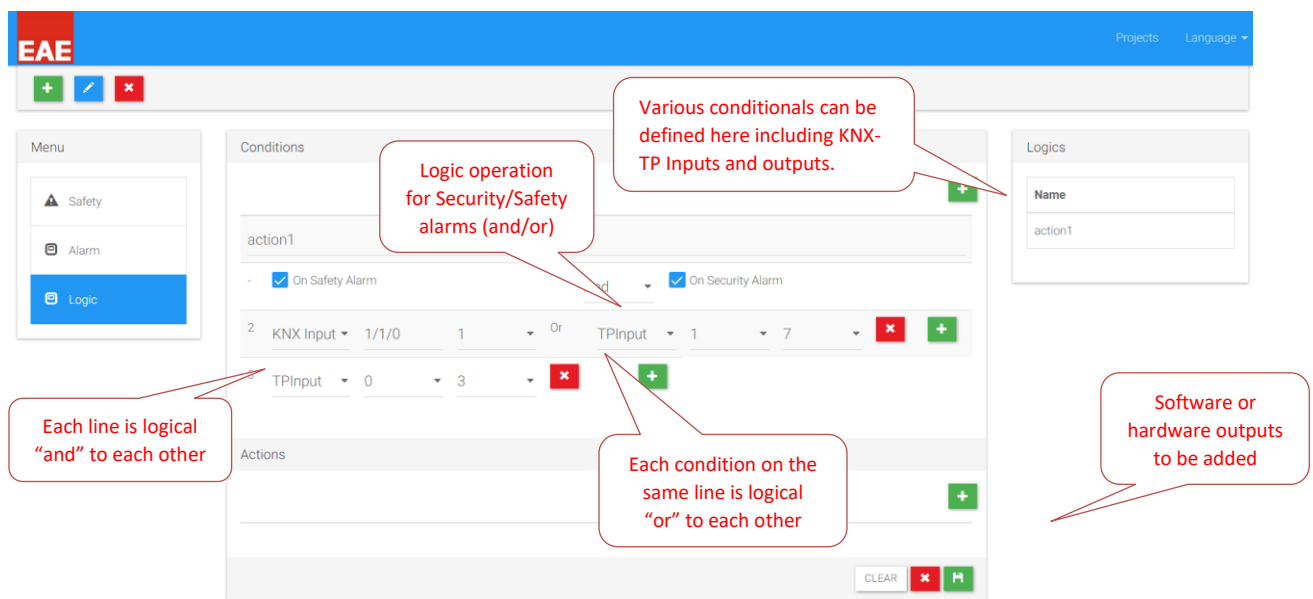

Click on the project -> Block -> Block Details -> Apartment and enter the parameters for the apartment.

Enter the parameters for each apartment by selecting the apartments under “Block Details” menu.

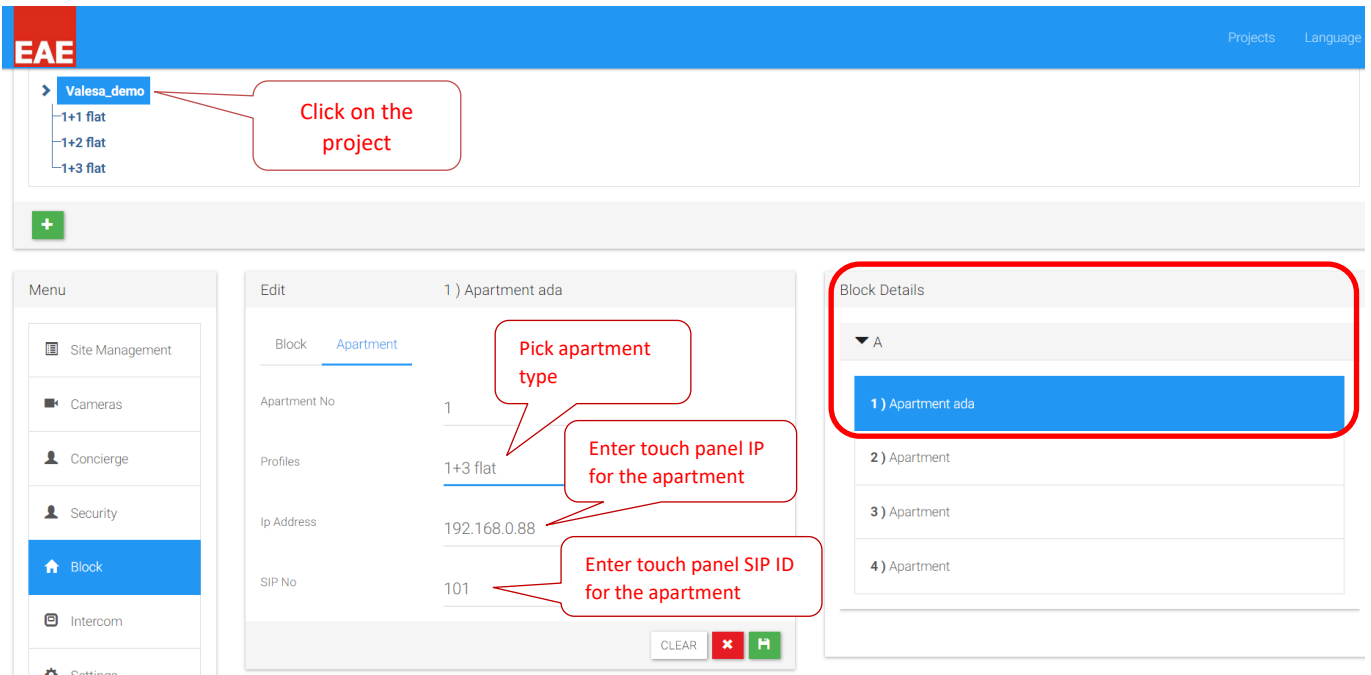

3.4 Rooms

Next step is to create rooms for each apartment type. To do so, click on the desired apartment type and add a room.

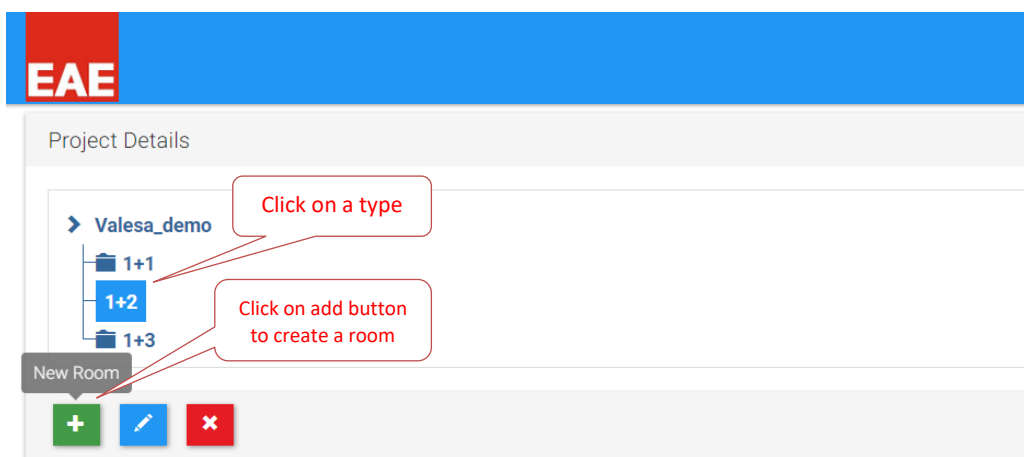

Once a room is created, you will be presented with KNX group parameters for Lighting, Blinds, Air Conditioning and General controls.

3.4.1 Lighting

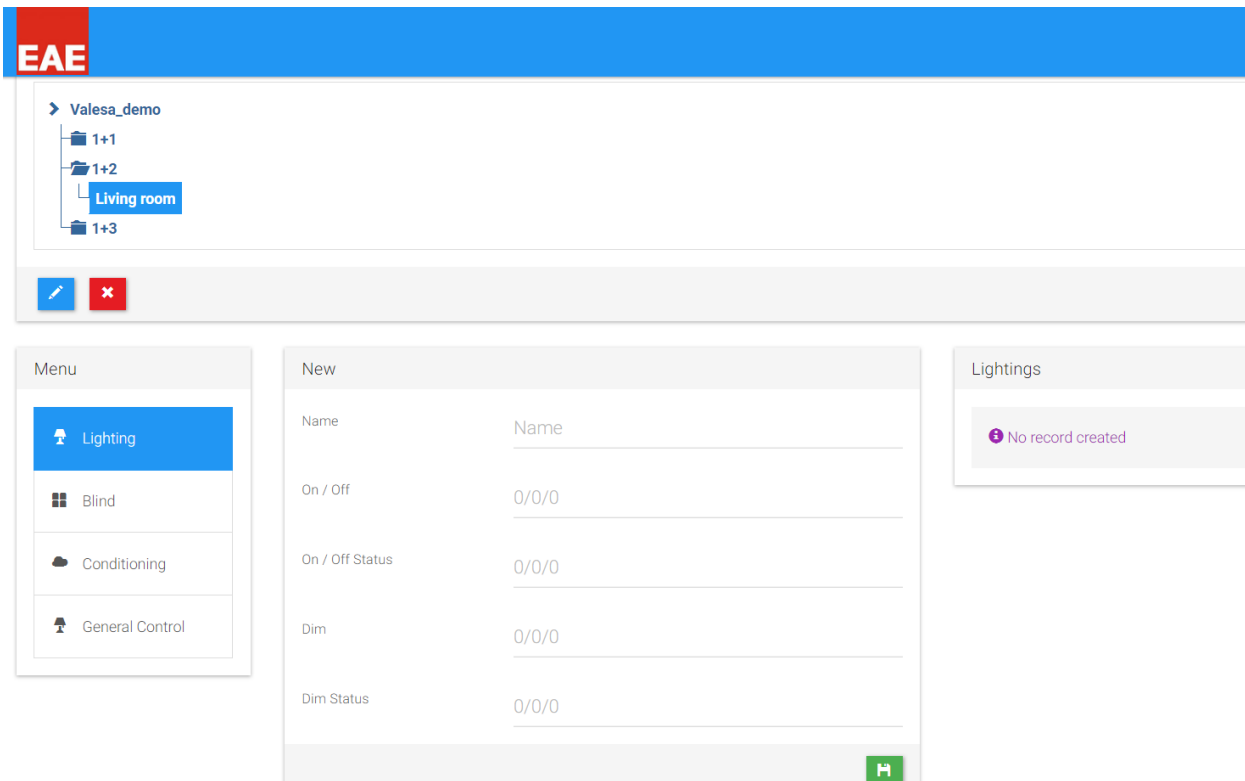

The screenshot shows the EAE configuration software interface. At the top, there is a blue header with the EAE logo. Below it, a tree view shows a project named 'Valesa_demo' with sub-items '1+1', '1+2', 'Living room', and '1+3'. The 'Living room' item is selected. Below the tree view, there are two icons: a blue pencil and a red 'X'. The main area is divided into three panels: 'Menu', 'New', and 'Lightings'. The 'Menu' panel on the left has four options: 'Lighting' (selected), 'Blind', 'Conditioning', and 'General Control'. The 'New' panel in the center has five input fields: 'Name', 'On / Off', 'On / Off Status', 'Dim', and 'Dim Status', each with a corresponding value field (e.g., 'Name' with 'Name', 'On / Off' with '0/0/0'). A green save icon is at the bottom right of the 'New' panel. The 'Lightings' panel on the right shows a message: 'No record created'.

Following visuals are examples for the configuration of the touch panel. KNX group parameters depend on the one who configures the ETS.

KNX Side configuration:

0/1/0 -> Move blind

0/1/2 -> Status height

0/0/1 -> Lights On/Off

0/0/5 -> Lights Status

The screenshot displays the ETS software interface with two windows open: 'Devices' and 'Group Addresses'.

Devices Window: Shows a list of devices with columns for Number, Name, Object Function, Description, Group Address, Length, C, R, W, T, U, Data Type, and Priority. The list includes various blind actuators and switches.

Group Addresses Window (Top): Shows a table of group addresses with columns for Address, Name, Description, Centre, Pass, T, Data Type, Length, and No. of Last Value. Two entries are highlighted with a red box:

Address	Name	Description	Centre	Pass	T	Data Type	Length	No. of Last Value
0/0/1	livingRoom_on_off		No	No		up/down	1 bit	1
0/0/5	livingRoom_onOff_Status		No	No		switch	1 bit	1

Group Addresses Window (Bottom): Shows another table of group addresses with similar columns. Two entries are highlighted with a red box:

Address	Name	Description	Centre	Pass	T	Data Type	Length	No. of Last Value
0/1/0	livingRoom_blind_move		No	No		percenta...	1 byte	1
0/1/2	livingRoom_blind_Status		No	No		percenta...	1 byte	1

Once the KNX groups for desired controls are created, group addresses must be written as parameters to touch panel configuration sections.

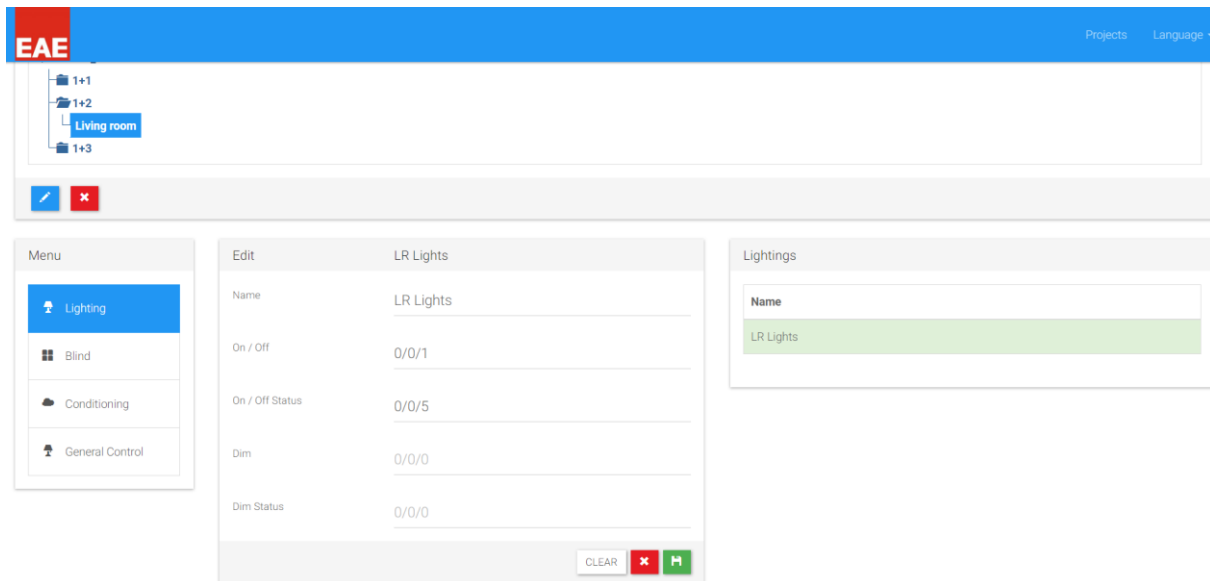

3.4.2 Blind

To control the blinds KNX side should be programmed with relevant Group objects. EAE RCU is preferred for the control of Blinds.

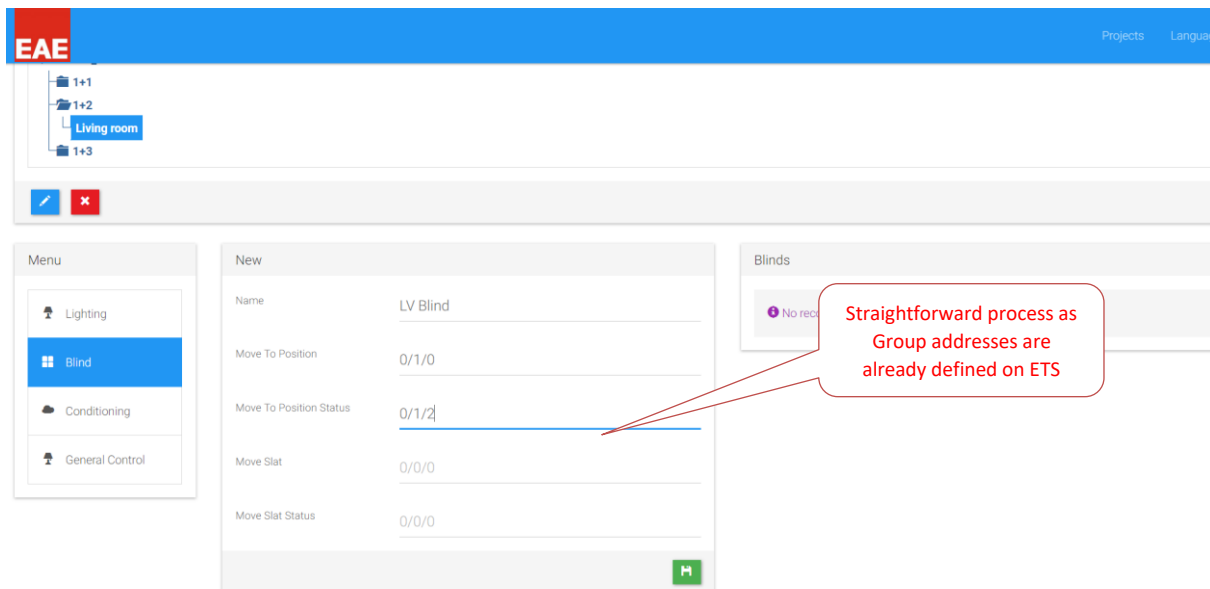

3.4.3 Conditioning

Most of the work is done on the KNX side for this section. KNX configuration should give an insight into configuring this part. For more information refer to document EAE KNX Thermostat Product Manual.

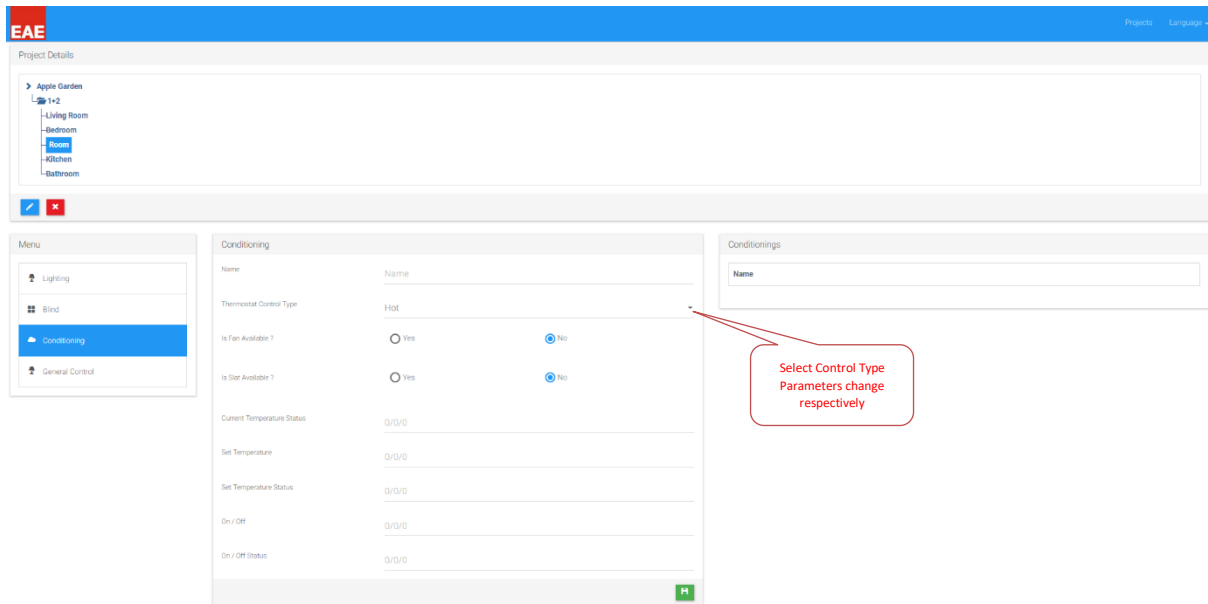

3.4.3.1 Hot or Cold

KNX Groups should be created prior to commence configuring this step.

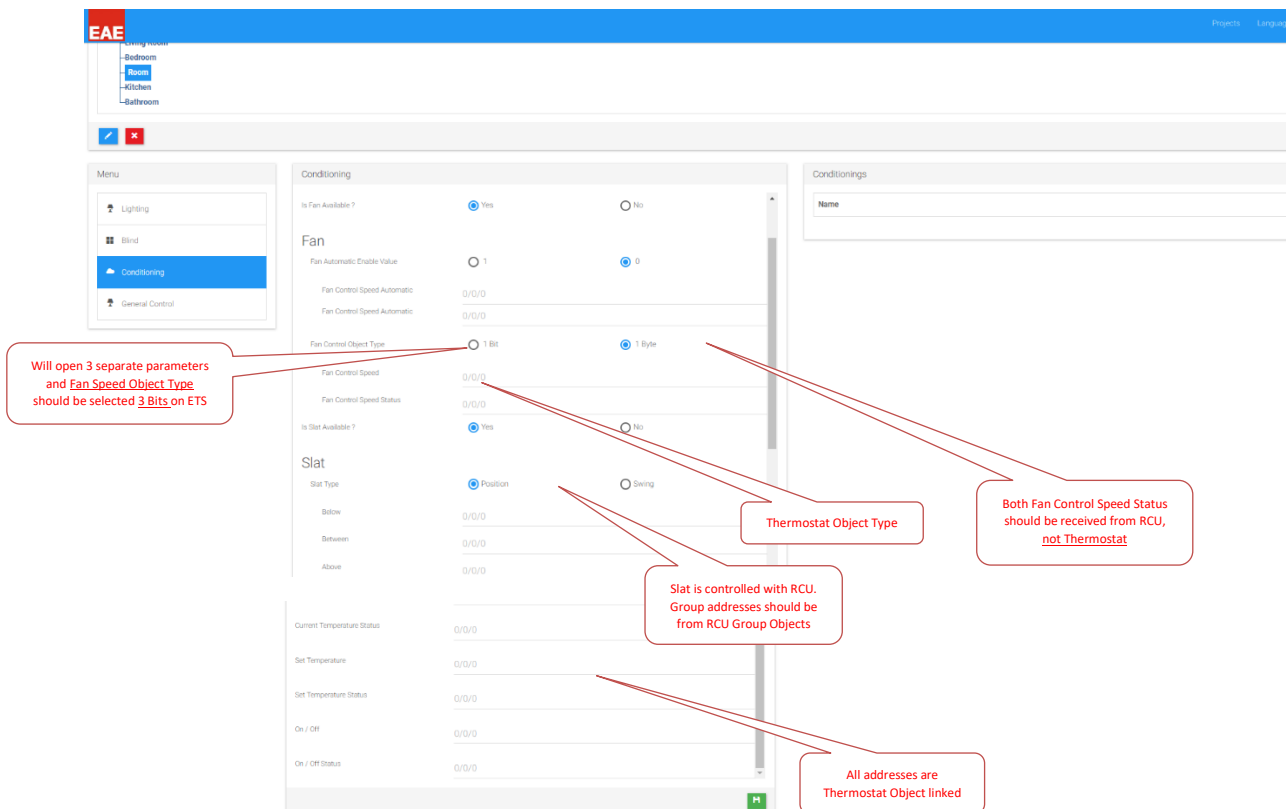

3.4.3.2 Hot / Cold

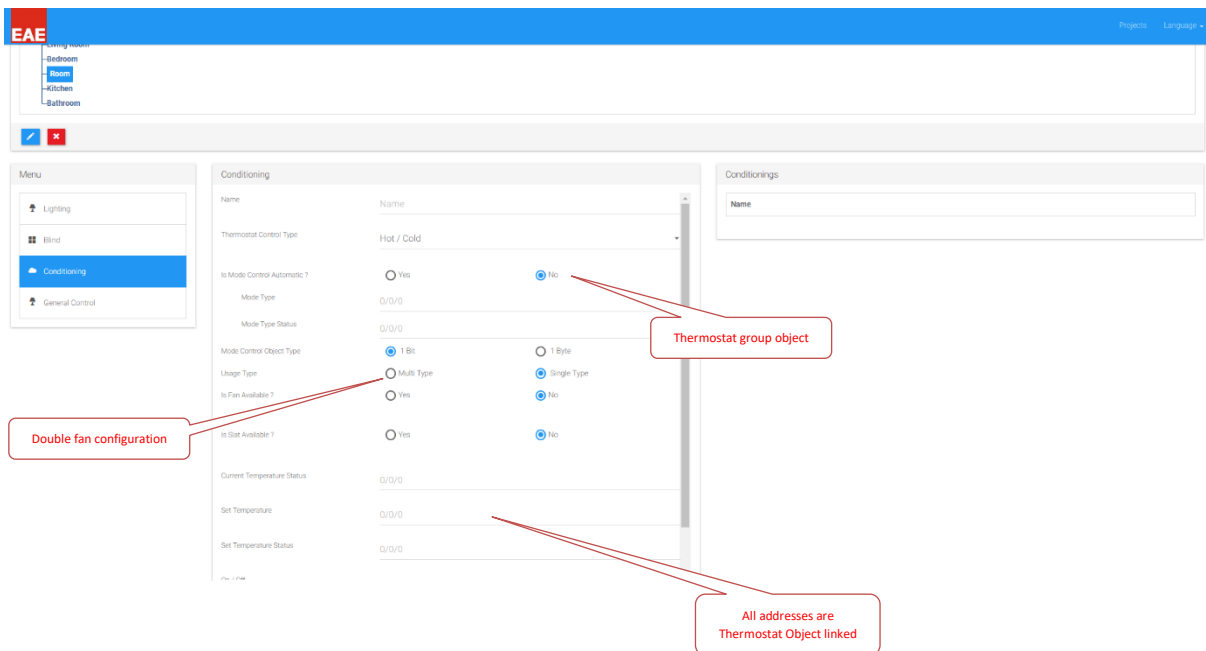

3.4.4 General Control

General Control section enables to send custom KNX On/Off commands to KNX bus. On/Off duration time can be assigned to these operations if necessary.

3.5 Intercom

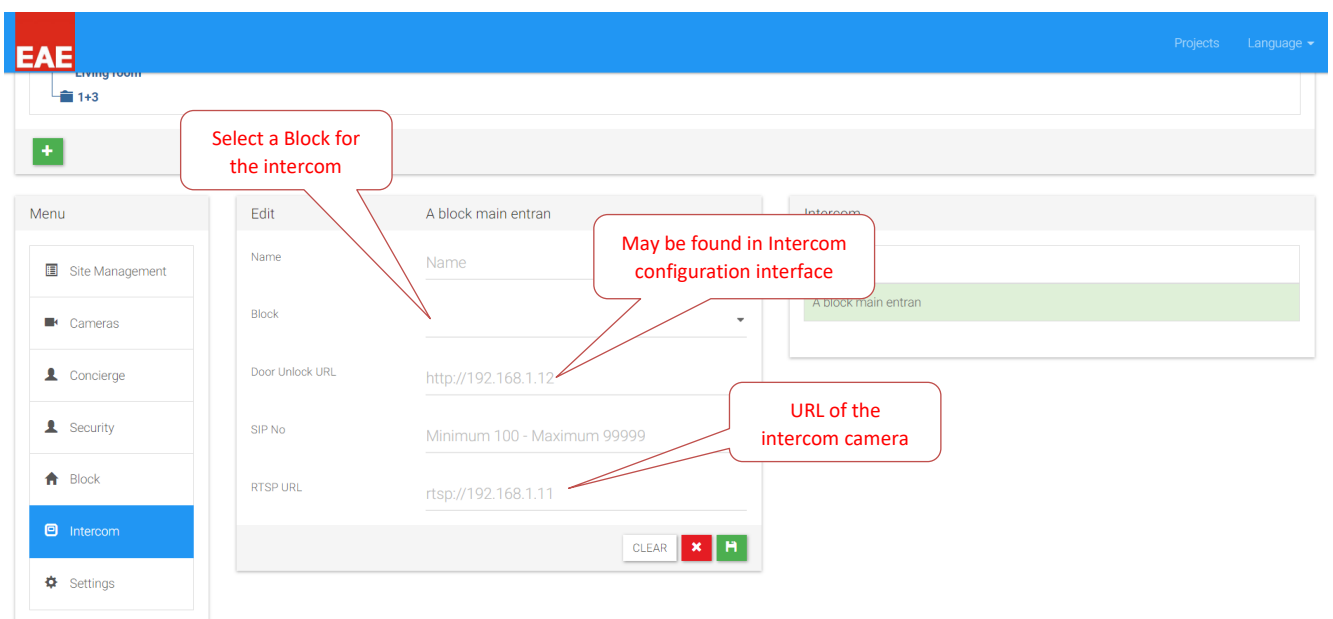

4. Configuring 3rd party devices

Valesa Touch Panel is built with flexibility to interact with various 3rd party devices. SIP server is essential for Valesa to communicate with 3rd party devices. Unless otherwise stated, be sure to conform to the communication standard requirements of protocols in the system.

4.1 Cameras

Cameras to be used in the system should support rtsp stream and h264 coding standard.

Unless you use a Network Video Recorder or NVR for short, it is recommended to assign static IP address to the cameras. Once IP address assignment is done, using the rtsp URL of each camera, you may add streams to Valesa.

If there is an NVR in the project, cameras should be configured to get dynamic IP addresses. Usually cameras come out of box with dynamic address configuration. NVR assigns each camera an IP and to add camera streams to Valesa, NVR creates a custom rtsp URL for using its own IP address. As an example, following is an NVR created rtsp URL:

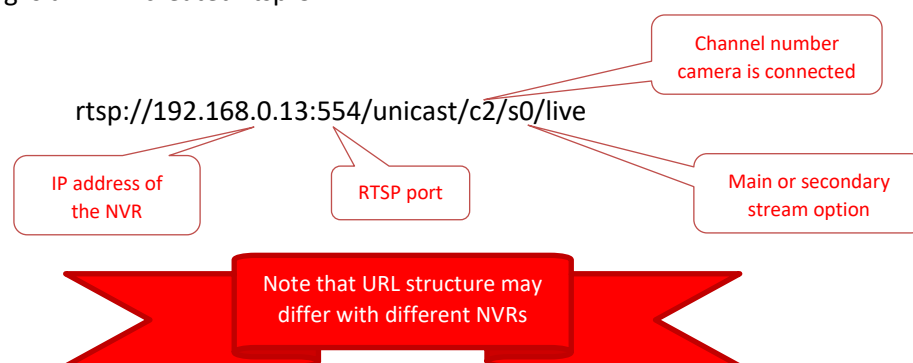

4.2 Intercoms

For an intercom device to work properly with Valesa, make sure Intercom is able to provide an rtsp URL for its integrated camera and an optional http URL to open the door. Depending on the intercom there might be different buttons on the panel. Configuration of these buttons are important as they are directed to SIP IDs. Akuvox intercoms and 2N Helios, Verso are tested and work with Valesa.

As an important note, example configuration is unique to the device. Any other 3rd party device may have a completely different user interface. However, logic behind the configuration should be parallel to that of the example below. Hence one who understands the logic behind the system, should be able to feel confident configuring the device.

4.2.1 Example configuration

AKUVOX model R26C V1.0 Programming for EAE SIP Server

Log in to the web interface of R26C Intercom from a PC browser that is on the same IP block with the device. (if static IP of device is 192.168.0.100, enter this IP into web browser.)

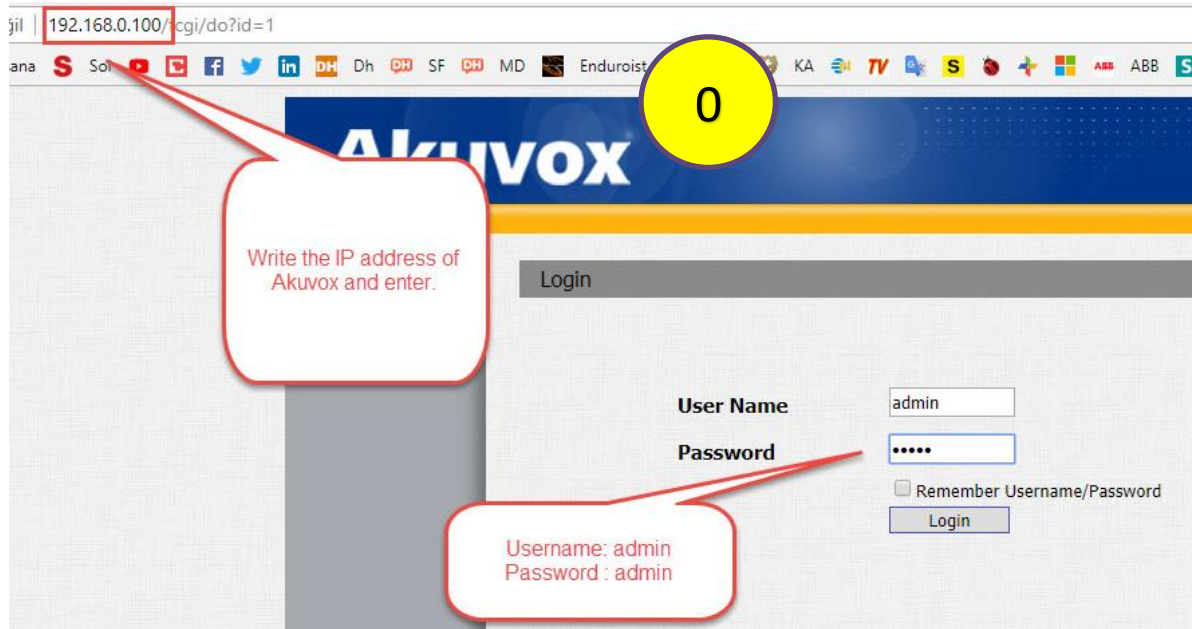

Note: Every example given with the abbreviation “i.e.” in this document is only for example purposes. Please be aware that your parameters may be different.

You must be greeted with the following screen.

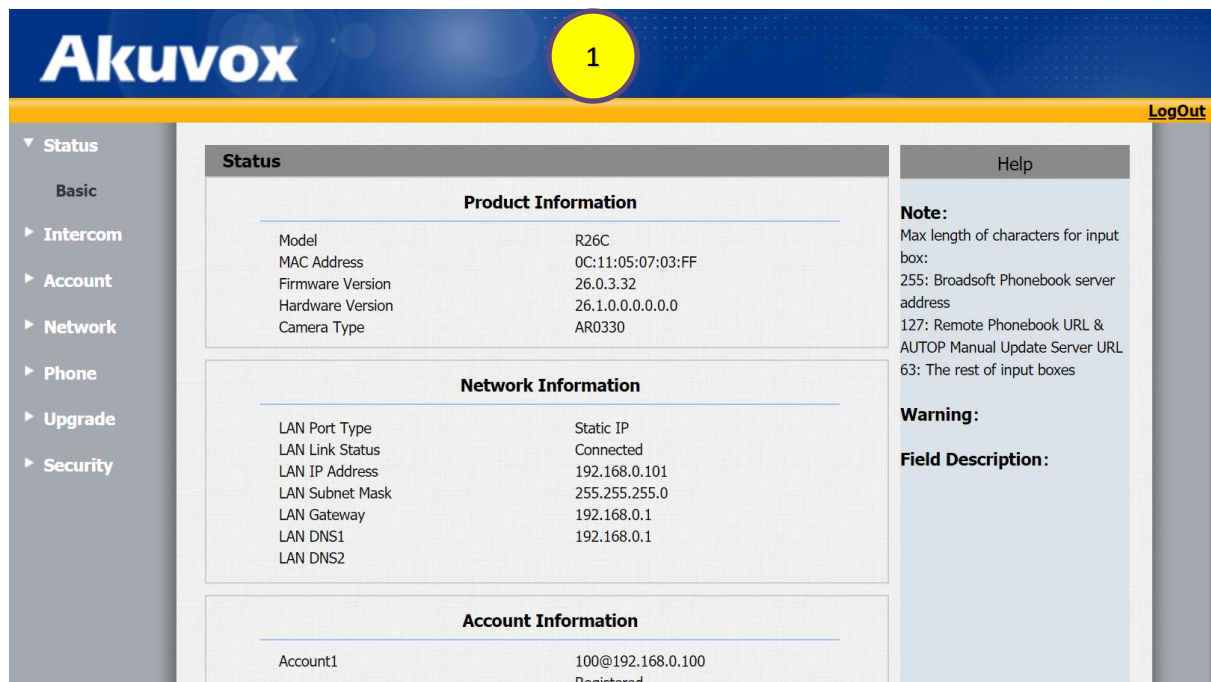

Make sure to give the Intercom device a static IP.
 (i.e. 192.168.0.101 your static IP, 192.168.0.1 Default gateway)

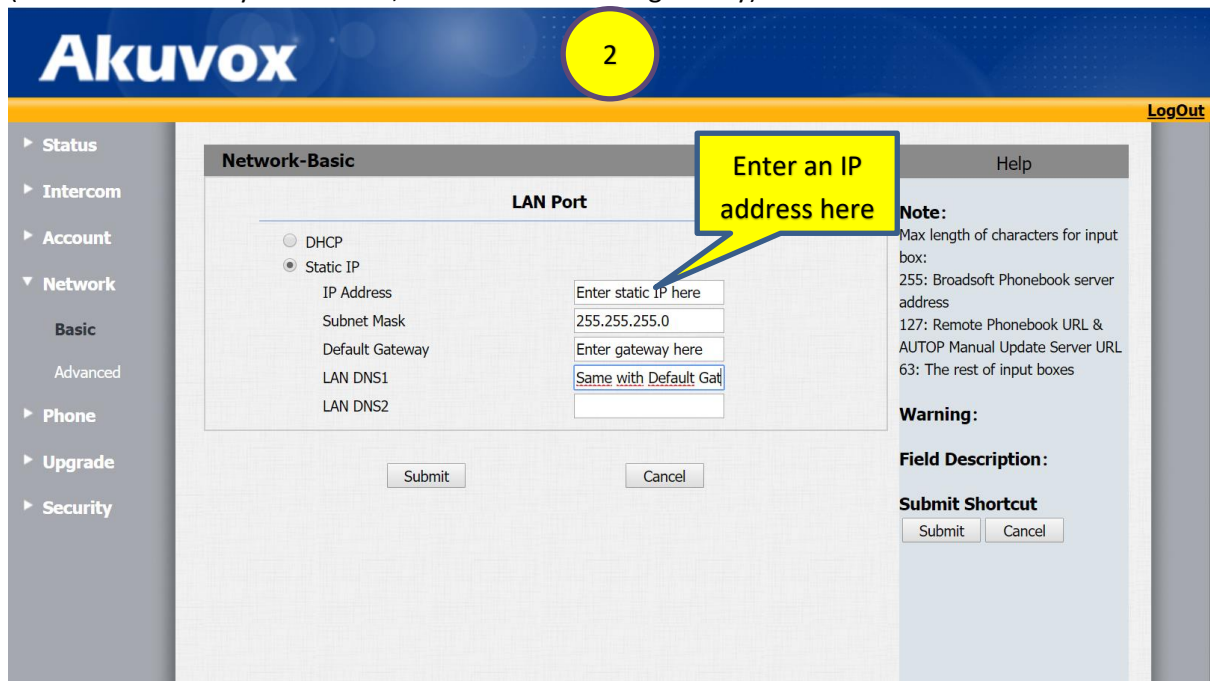

From the left side menu, click on the Account -> Basic tab.
 Make sure Account1 is selected in the "Account" section.
 "Display Label/Name", "Register Name", "User Name" should be the SIP ID you have given to the device. (i.e. 100)
 "Password" has to be: PINcodeXXX where XXX is the SIP ID you have given to this device.
 (i.e. PINcode100)
 "Server IP" part must be the IP address of the SIP server and "Port" should be 5060.

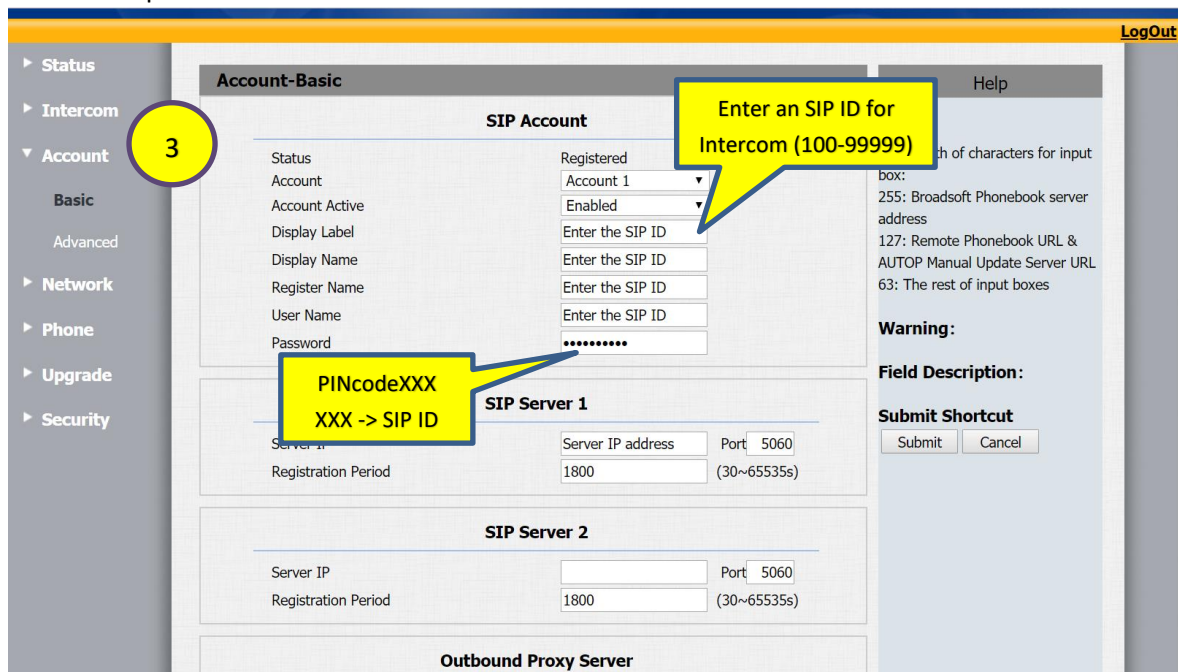

Next click on Intercom -> Basic tab from the left-hand side.

“Select Account” should be Account1 as we have configured the user Account1 of the device.
 Enter the SIP number of the IP Telephone you want to call into the “Push Button” box. (between 100-9999). Also, “Pushbutton Action” offers a link for opening door that may be used in touch panel configuration.



Click on the Status -> Basic tab.

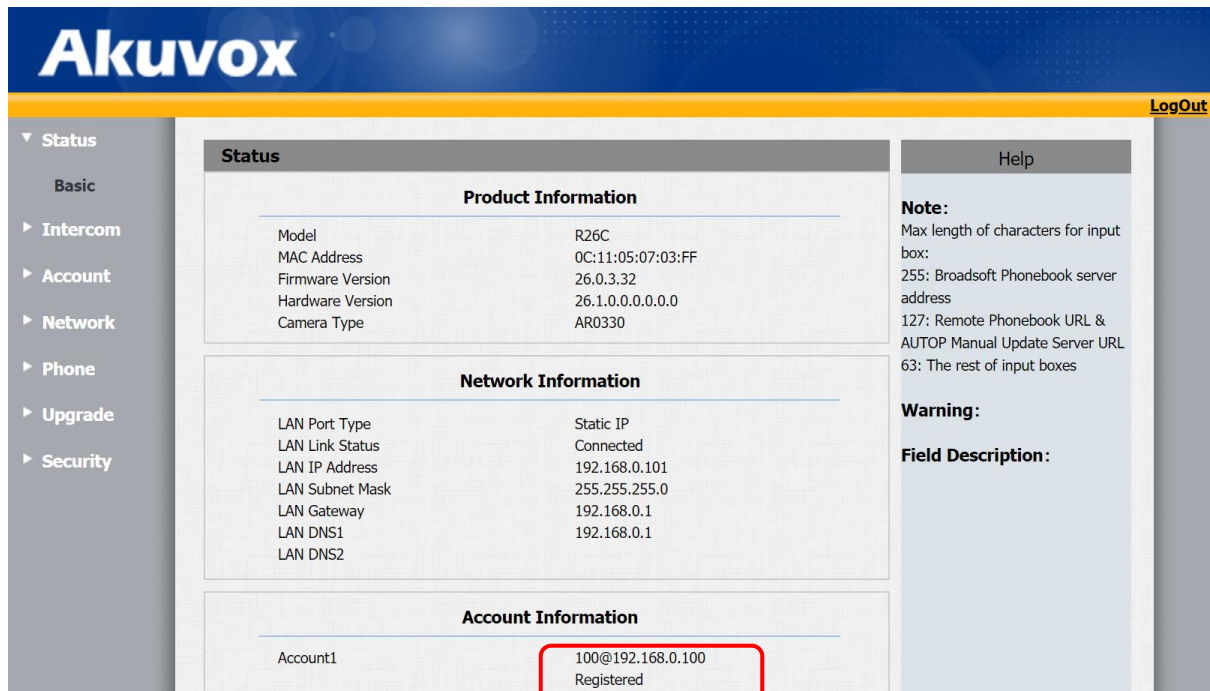

After the configuration of the SIP server, Account1 below the “Account Information” must be:

deviceSIPID@serverSIPID
Registered

If it stays **unregistered** make sure you have configured the SIP Server. If not check this page after you configure the SIP Server. If you still experience problems and sure that SIP server is configured correctly, this device is not configured right.

4.3 IP Telephones

VOIP telephones that have SIP support can be connected to the system. Calls can be made to/from the touch panels. Configuration of telephones are straightforward and the logic behind the telephone is pretty much similar to that of an intercom. Siemens Yealink SIP-T21 E2 and Gigaset DE410 IP PRO are tested and work with Valesa.

As an important note, example configuration is unique to the device. Any other 3rd party device may have a completely different user interface. However, logic behind the configuration should be parallel to that of the example below. Hence one who understands the logic behind the system, should be able to feel confident configuring the device.

4.3.1 Example configuration

Gigaset DE410 IP Pro Configuration

You must give a unique static IP to the phone. You can do it using the buttons on the phone locally. For more information check the documentation of the device :

http://gse.gigaset.com/fileadmin/legacy-assets/A31008-M2219-L101-4-7619_en_UK-IE.pdf

Note: Every example given with abbreviation i.e. in this document is only for example purposes. Please be aware that your parameters may be different.

After the initial IP configuration, you should see this page as you enter the web interface of the device with the default password: admin

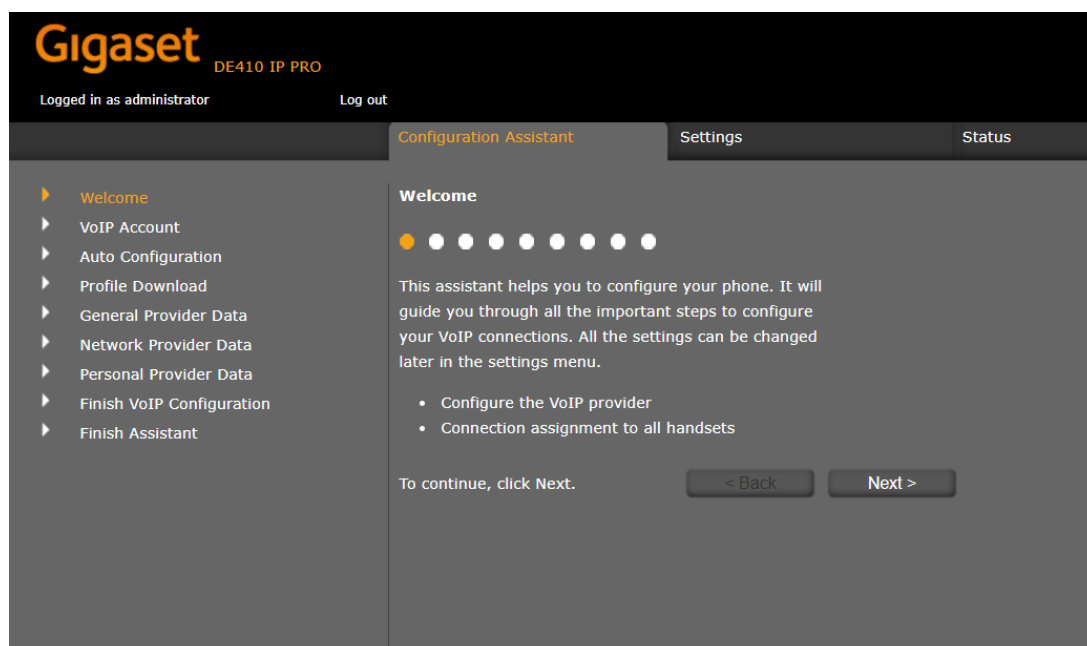

Click on “Settings” tab and then “Telephony” from the left side menu. You must land on this page:

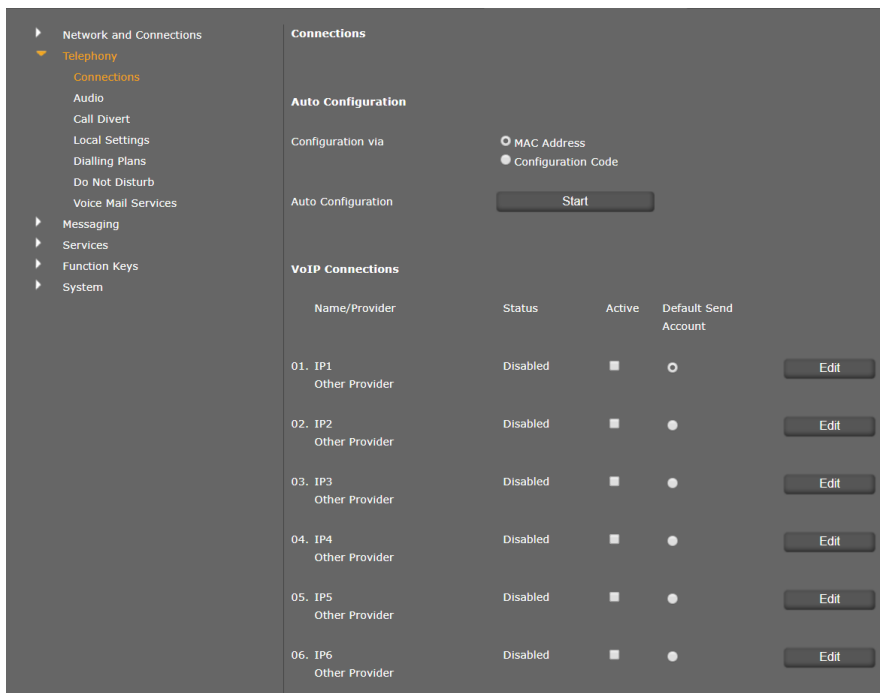

Click on the Edit button of the first Provider “IP1”. You should see the screen below:

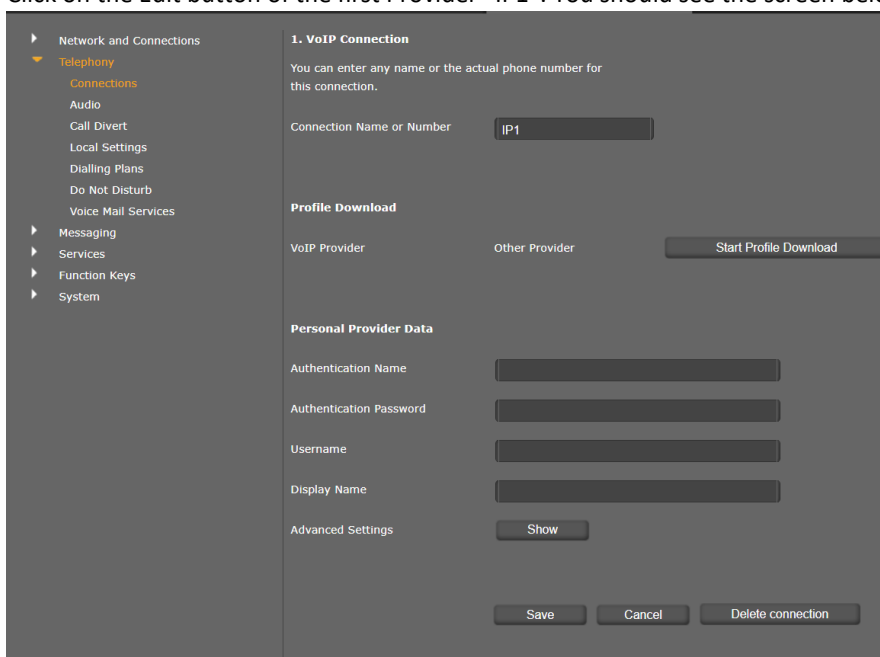

Change the Connection name to something you want to name the phone.

Fill in the boxes as explained below:

Authentication Name: SipID (i.e.321)

Authentication Password: PINcodeXXX where XXX is the authentication name. (i.e. PINcode321)

Username: SipID (i.e. 321)

Display Name: Name that will be seen on the telephone screen. (i.e. Security B Entrance)

Next click on the “Show” button for Advanced Settings.

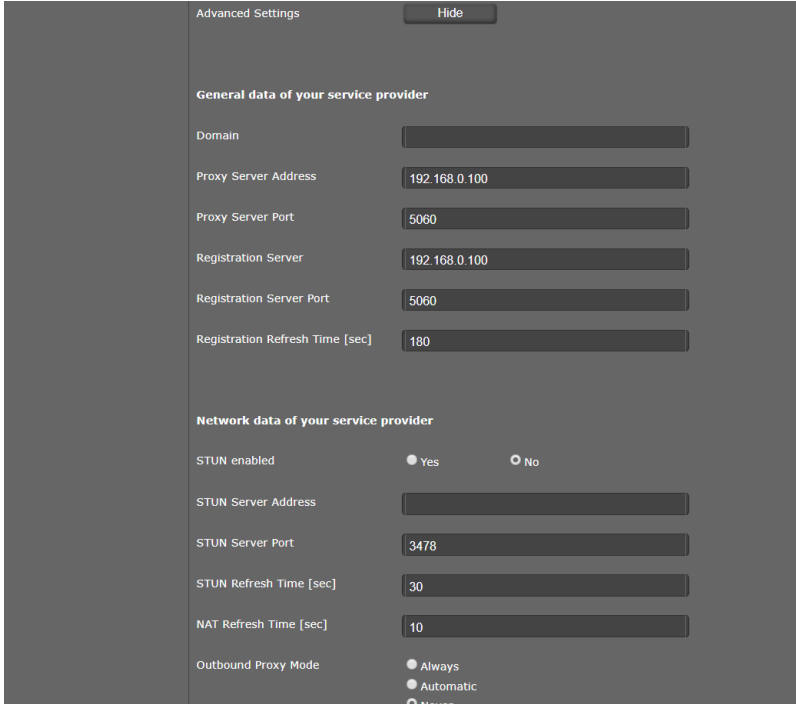

Advanced Settings Hide

General data of your service provider

Domain

Proxy Server Address

Proxy Server Port

Registration Server

Registration Server Port

Registration Refresh Time [sec]

Network data of your service provider

STUN enabled Yes No

STUN Server Address

STUN Server Port

STUN Refresh Time [sec]

NAT Refresh Time [sec]

Outbound Proxy Mode Always Automatic Never

Proxy Server Port: 5060

Registration Server: SIP ID server IP (i.e. 192.168.0.100)

Registration Server Port: 5060

Click “Save” and you will be taken back to the following page:

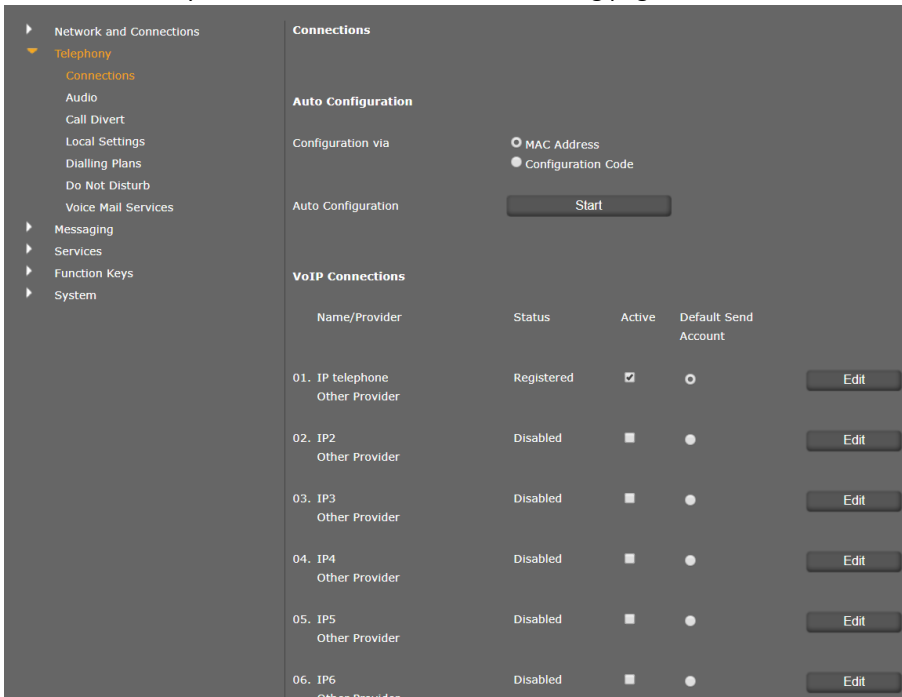

Network and Connections

- Telephony
 - Connections
 - Audio
 - Call Divert
 - Local Settings
 - Dialling Plans
 - Do Not Disturb
 - Voice Mail Services
- Messaging
- Services
- Function Keys
- System

Connections

Auto Configuration

Configuration via MAC Address Configuration Code

Auto Configuration Start

VoIP Connections

Name/Provider	Status	Active	Default Send Account	
01. IP telephone Other Provider	Registered	<input checked="" type="checkbox"/>	<input type="radio"/>	Edit
02. IP2 Other Provider	Disabled	<input type="checkbox"/>	<input type="radio"/>	Edit
03. IP3 Other Provider	Disabled	<input type="checkbox"/>	<input type="radio"/>	Edit
04. IP4 Other Provider	Disabled	<input type="checkbox"/>	<input type="radio"/>	Edit
05. IP5 Other Provider	Disabled	<input type="checkbox"/>	<input type="radio"/>	Edit
06. IP6 Other Provider	Disabled	<input type="checkbox"/>	<input type="radio"/>	Edit

Wait for a few minutes and the status of the configured Name/Provider should turn to “**Registered**”.

If it is **unregistered** make sure you have configured the SIP Server. If not check this page again after you configure the SIP Server. If you still experience problems and sure that SIP server is configured correctly, this device is not configured right.

5. Importing project into Touch Panel

There are 2 ways to import a project into Valesa: Site Server User Interface or a USB.

After you are done with Smart Home Configurator navigate back to projects. Export the project to obtain a .eaeprofile file.

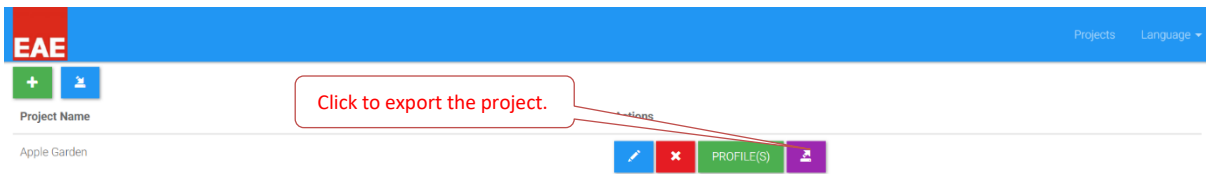
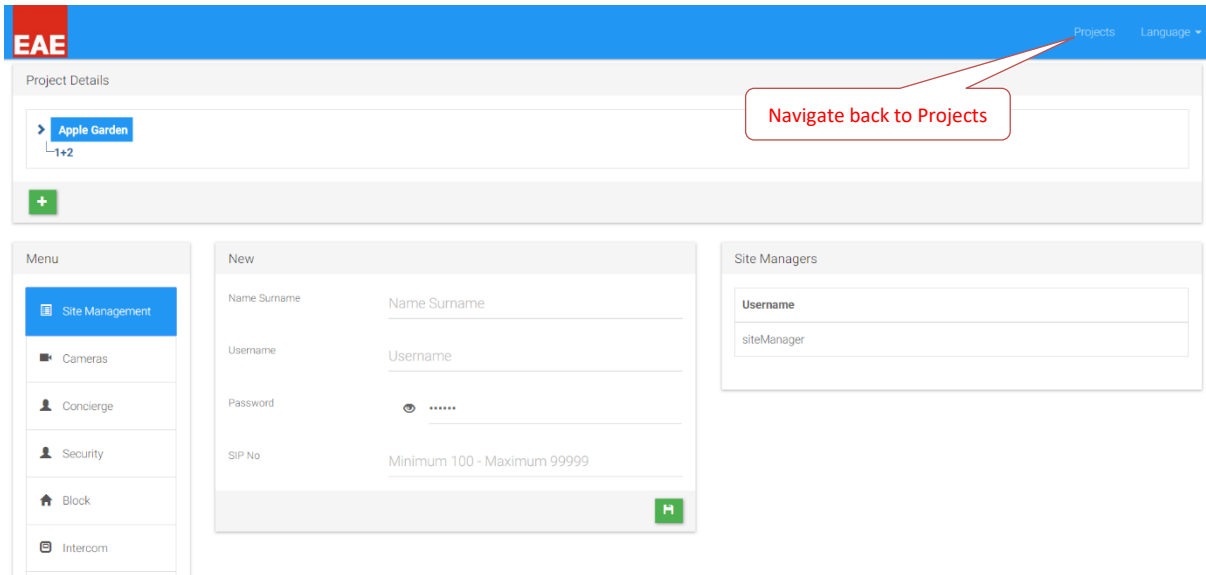

5.1 Remote project import to Valesa

Out-of-the-box Valesa gets a dynamic IP address from the site server.

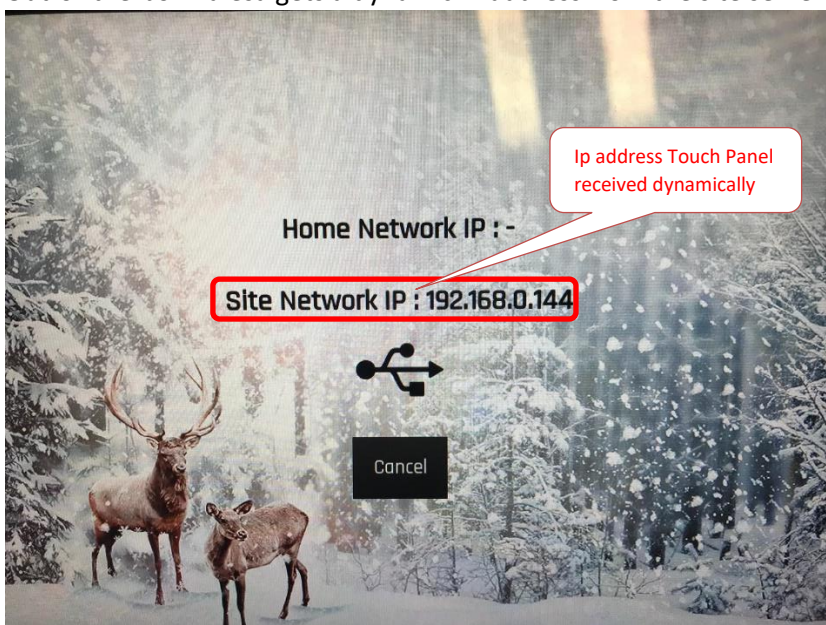

To import project to Valesa remotely, login to Site Server User Interface. Refer section 2.1.1 for more information. Once you are logged in, make sure a copy of project is uploaded and imported into Site Server.

Navigate to Touch Panel section and follow the instructions below.

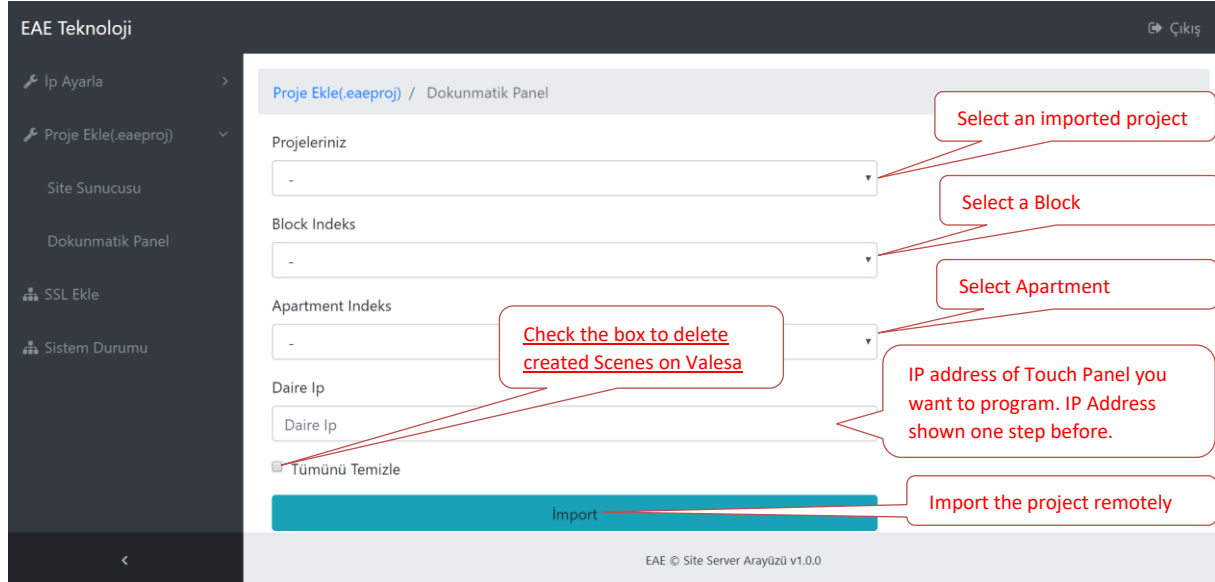

5.2 Local project import to Valesa

To import the project to Valesa locally, a USB is required.

Important: In order to import the project, exported “.eaeproj” file has to be inside a folder with specific name “projects”.

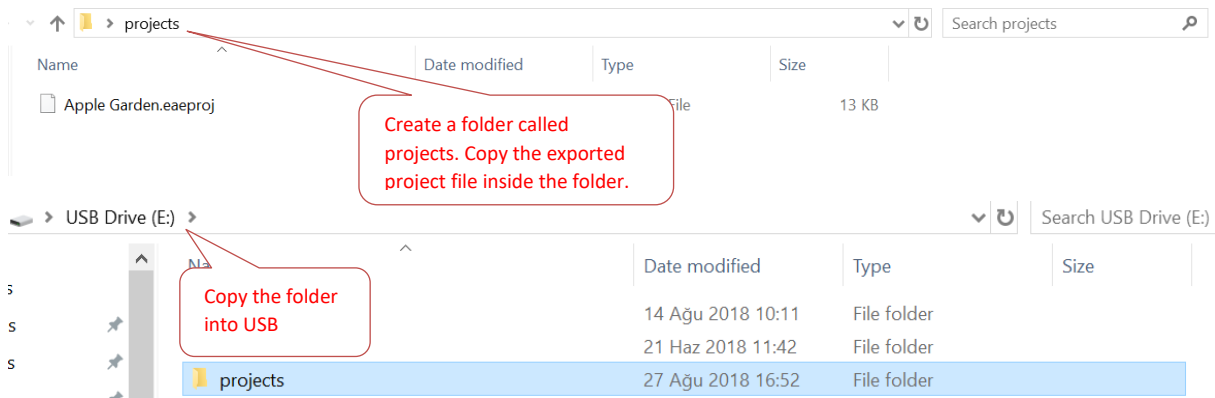

Next, copy the project folder (projects) to the USB. Connect USB to Valesa. If Valesa has never been programmed before, it will attempt to import the project automatically.

Else you should go through the following steps below to import a new project into Valesa:

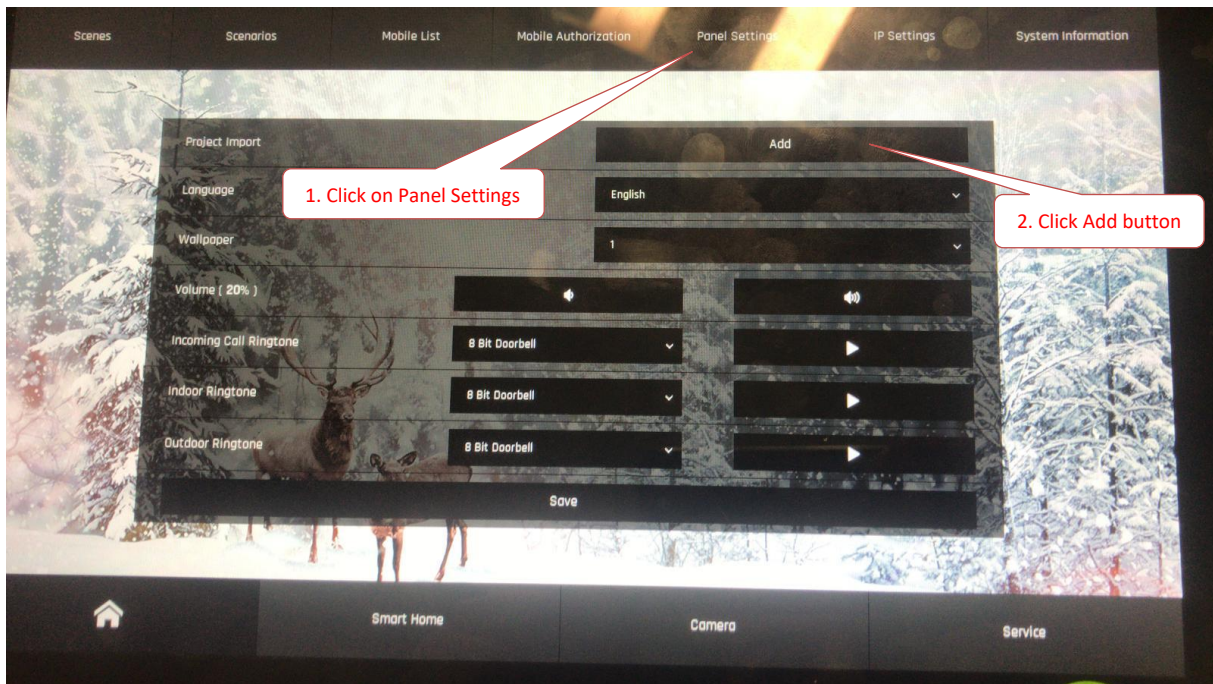
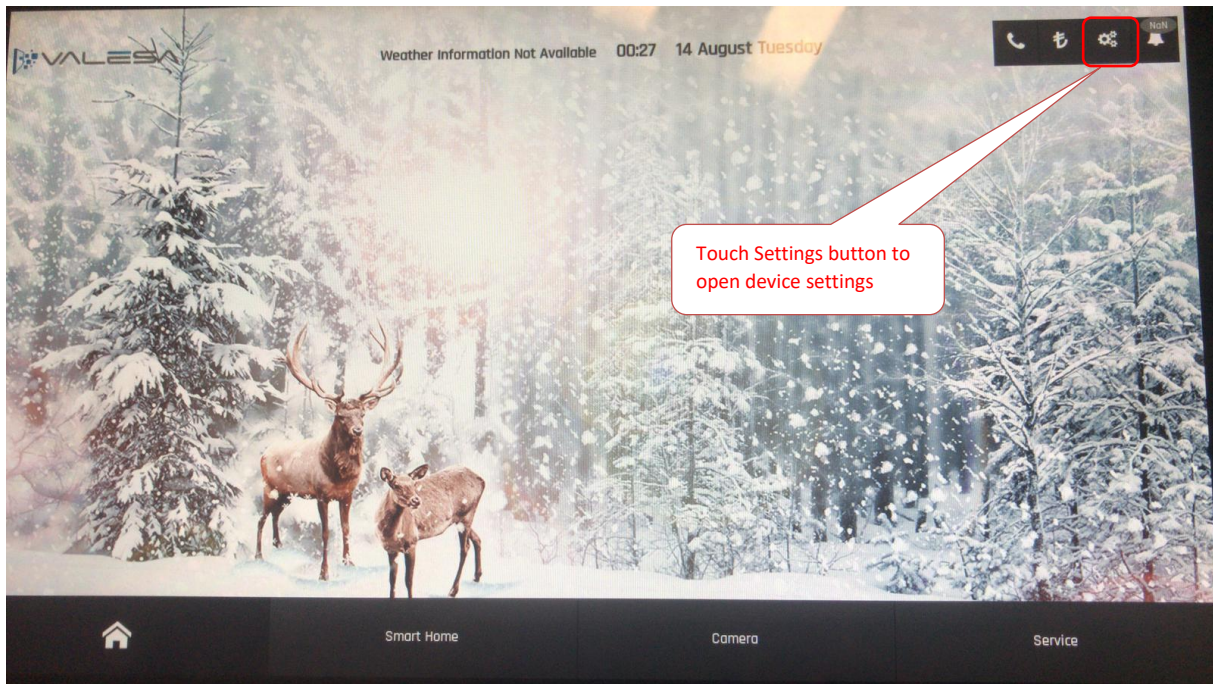

You will be asked to select the Block/Apartment to be imported:

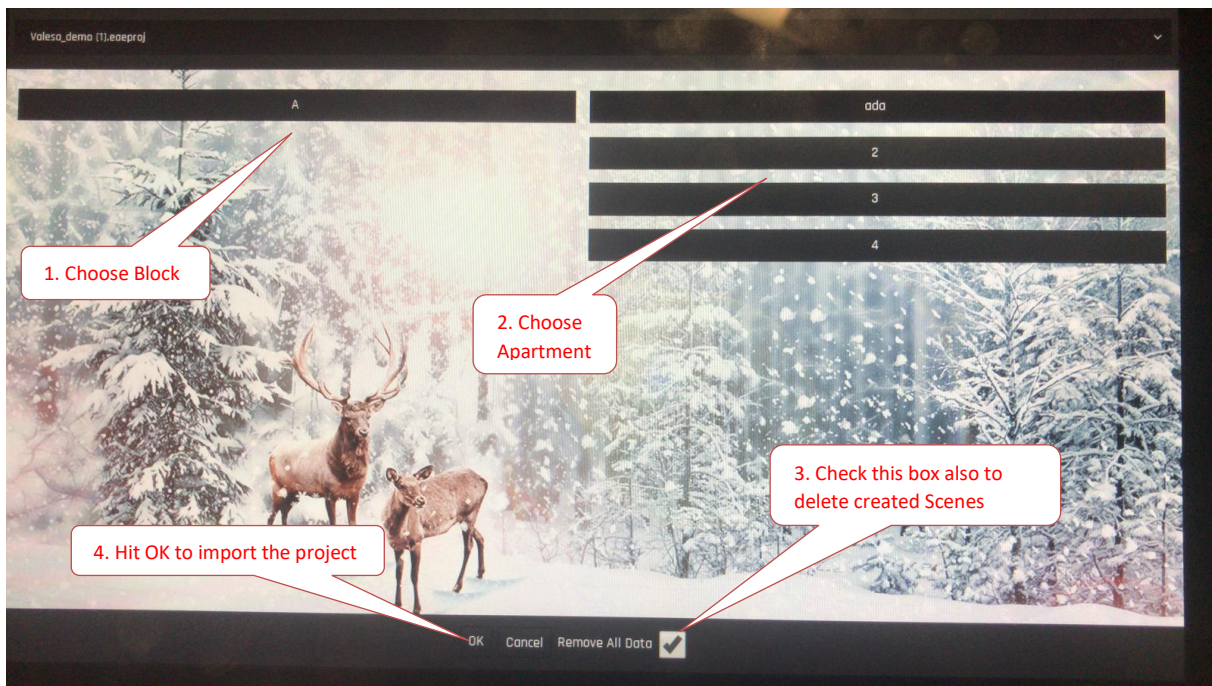

Once import process is successful, device will restart itself.

6. Example project

This section covers the steps for a successful project configuration. Please refer to this section after you fully understand the sections 1 – 5. Unless the general aspects of the system are understood well, skipping directly to this section may confuse the reader.

6.1 Overview of the project

The project is a small site called Apple Garden with a single block. Name of the block is A Block. The 3-story block has six 1+2 apartments and following features:

- 1 Security room with an SIP Telephone
- 1 Site server (includes SIP Server)
- 1 Site manager
- 1 Internet server
- 1 intercom device
- 1 camera
- 1 Valesa Touch Panel for each apartment



Each apartment has safety equipment for gas, electric and city water systems.
 Each apartment has burglar alarm.
 Each apartment has the following floor room plan & features:

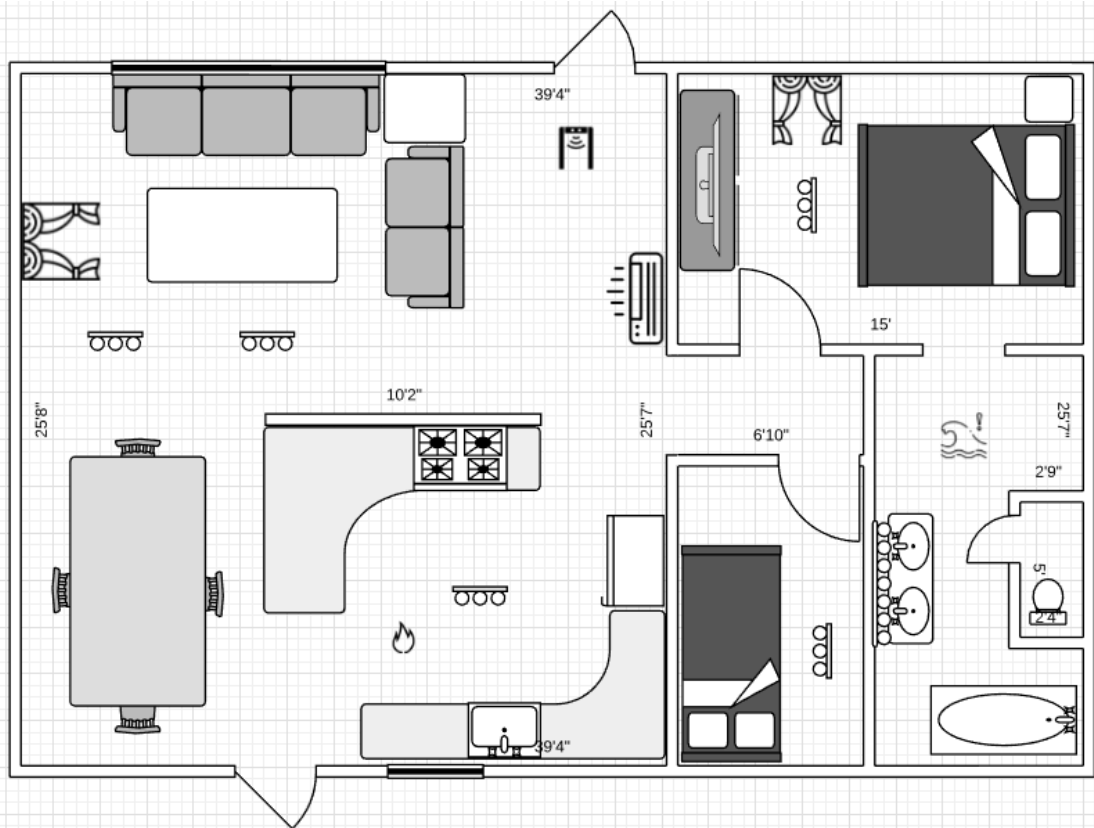

- Living room features:
 - 2 light groups
 - 1 air conditioner
 - 1 PIR for burglar alarm
 - 1 magnetic door contact
 - 1 siren for burglar alarm

- 1 window blind
- Bedroom features:
 - 1 window blind
 - 1 light group
 - 1 magnetic window contact
- Room features:
 - 1 light group
- Kitchen features:
 - 1 light group
 - 1 smoke detector
- Bathroom features:
 - 1 flood sensor
 - 1 light group

6.2 Creating the Project

Smart home configurator is installed and launched. A new project called “Apple Garden” is created. There is only a single apartment type in the project, hence one 1+2 type is created.

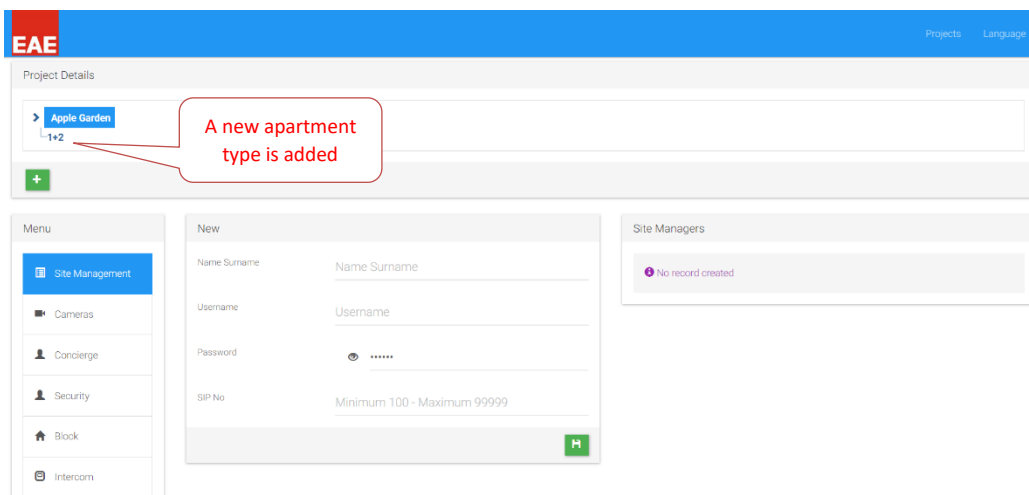

It's time to create the block and its apartments.

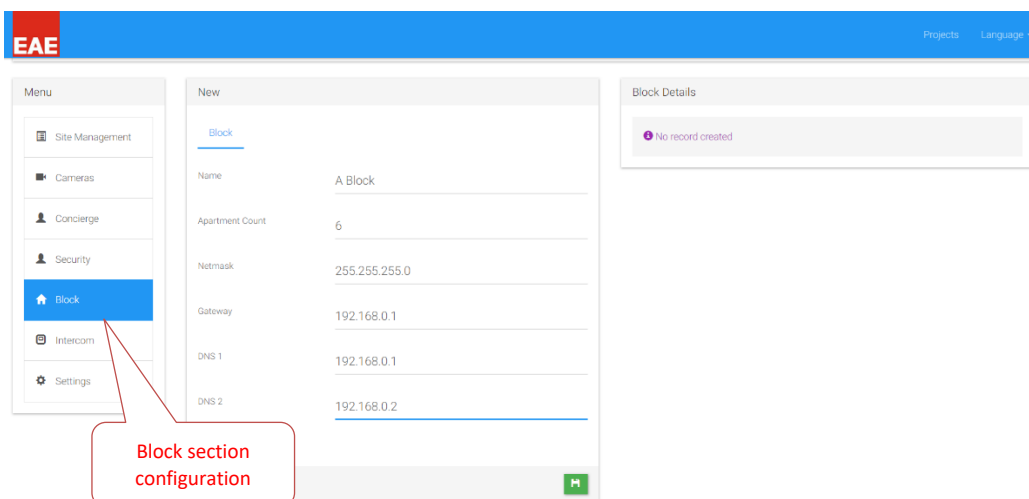

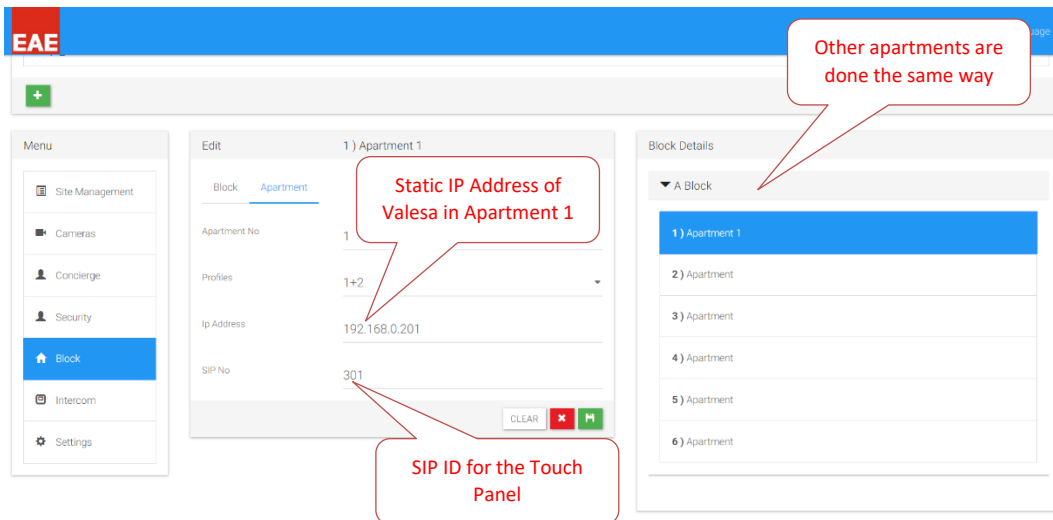

6.3 Configuring 3rd party devices

Each 3rd party device requires configuration for SIP. It is usually done by logging into configuration interface of each device and changing some parameters. After the completion of this step following SIP IDs are assigned to devices.

Security telephone -> 321
 Intercom device -> 100
 Site Manager -> 204
 Concierge -> 201
 Touch Panels -> 301-306

Camera is located facing the entrance door and it will be referred as Door Cam from this point to the rest of this document.

For this project an NVR is not be used since there is not many cameras. Hence following static IP address is given to the camera.

Door Cam -> 102.168.0.227

[For more information refer to section 4 of this manual.](#)

Configuration of 3rd party devices has been done after this step.

6.4 Configuring Site SIP Server

At this step, SIP users are defined in the SIP server. To do so, by logging in the SIP server URL: <http://192.168.0.100:8080/sip>

User authentication configurations are done. Next, as observed the security telephone and the intercom are registered on the SIP server. For more information refer section 2.

The screenshot shows the 'Registered Clients' page in the SIP Server interface. The browser address bar shows '192.168.0.100:8080/sip/gate'. The left sidebar contains a navigation menu with 'SIP SERVER' expanded, showing options like 'Registered Clients', 'Active Sessions', 'User Authentication', 'Dial Plan', 'Aliases', 'Logs', 'CDR', 'Push Notification', 'Domains', and 'Configuration'. The main content area displays a table of registered clients with columns for 'User', 'Contact URI (Source IP Address)', and 'Details'. Two clients are listed: one with user ID 100 and another with user ID 321. A red callout box with the text 'Expected devices are registered' points to the two rows in the table.

User	Contact URI (Source IP Address)	Details
100	sip:100@192.168.0.101:5062 (192.168.0.101:47474)	Expires : 1800 Priority : 1000 User Agent : R26C 26.0.3.32 0C11050703FF Transport : TCP Time Update : Wed Sep 05 17:40:38 EET 2018
321	sip:321@192.168.0.57:5060 (192.168.0.57:5060)	Expires : 180 Priority : 1000 User Agent : DE410 IP PRO/62.02.01.00;7C2F8020E317 Transport : UDP Time Update : Wed Sep 05 17:41:06 EET 2018

6.5 Configuring Valesa Settings

The screenshot shows the 'SIP Site Server' settings page. The top navigation bar includes the EAE logo and 'Projects' and 'Language' dropdowns. A sidebar menu on the left lists 'Site Management', 'Cameras', 'Concierge', and 'Security'. The main settings area has tabs for 'SIP Site Server', 'Site Server', 'DNS', 'Language', and 'Coordinate'. The 'SIP Site Server' tab is active, showing fields for 'IP Address' (192.168.0.100) and 'Password' (1234). A red callout box points to the 'Setting Menu' icon in the sidebar. Another red callout box points to the 'Password' field with the text 'SIP Site Server IP Random password'.

The screenshot shows the 'Site Server' settings page. The top navigation bar includes the EAE logo and 'Projects' and 'Language' dropdowns. A sidebar menu on the left lists 'Site Management', 'Cameras', 'Concierge', and 'Security'. The main settings area has tabs for 'SIP Site Server', 'Site Server', 'DNS', 'Language', and 'Coordinate'. The 'Site Server' tab is active, showing fields for 'Ip Address' (192.168.0.100) and 'URL' (https://applegarden.com). A red callout box points to the 'URL' field with the text 'URL should have SSL certificate & is specific to each project. Crucial for mobile application connection'.

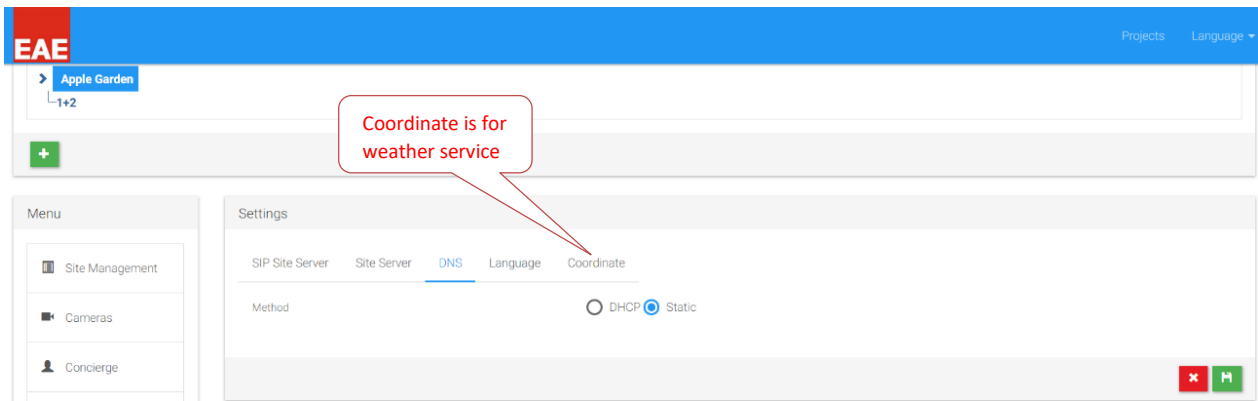

6.6 Connecting 3rd party devices to Valesa

As SIP configurations are done both for the 3rd party devices and Valesa, time has come to communicate devices with Valesa through site server.

6.6.1 Site Management

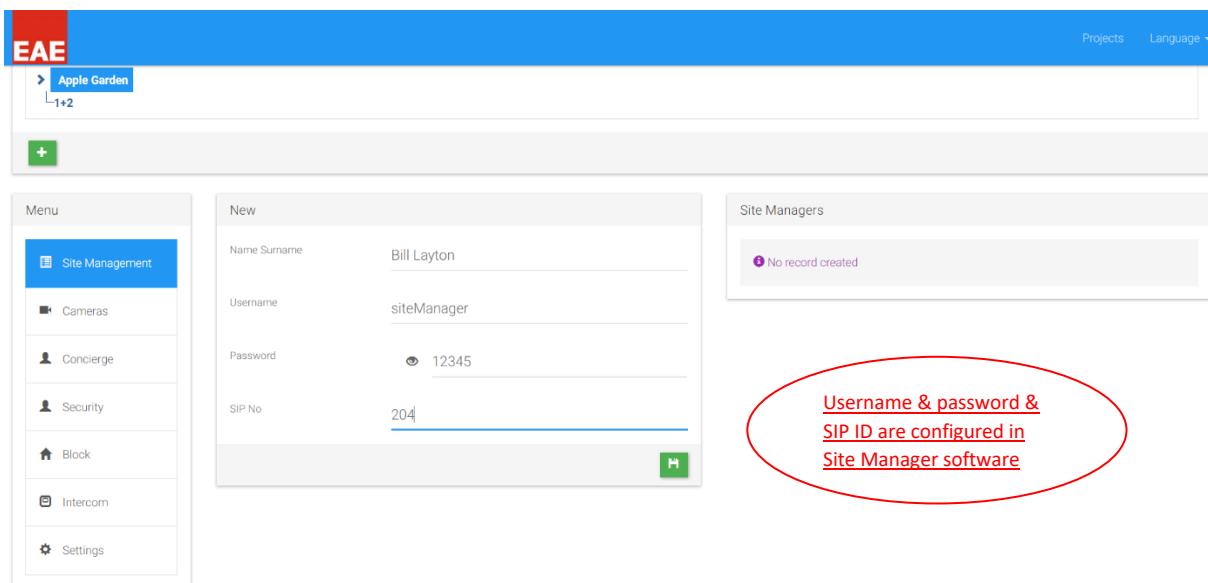

6.6.2 Cameras

Camera is given an IP address at section 6.3 and has the following rtsp URL:
rtsp://192.168.0.227:554/.

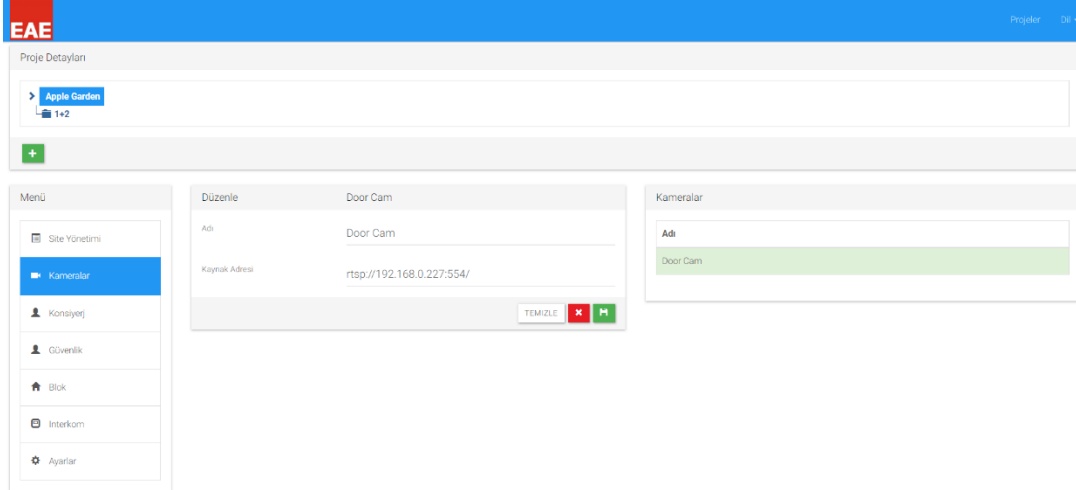

6.6.3 Concierge

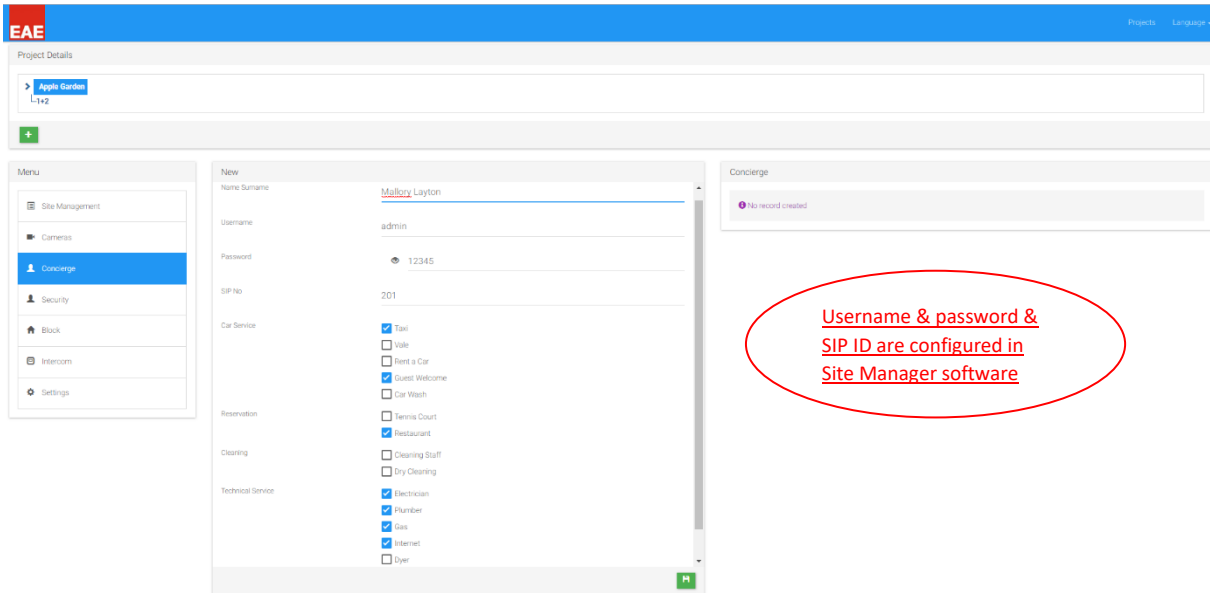

For more information refer section 3.1.

6.6.4 Security

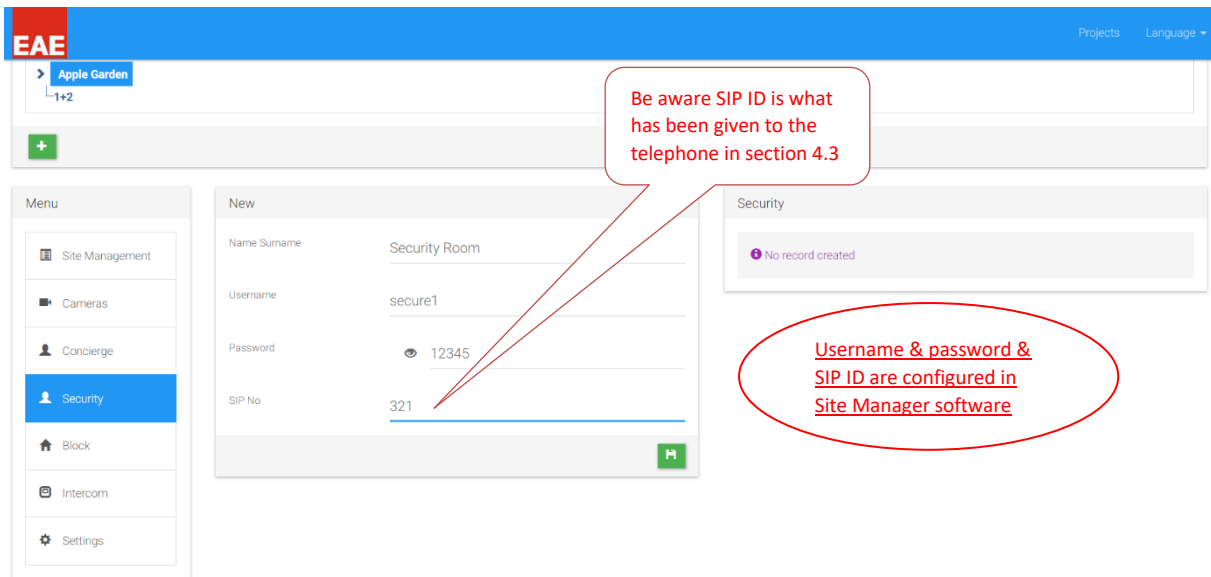

For more information refer section 3 & 4.

6.6.5 Intercom

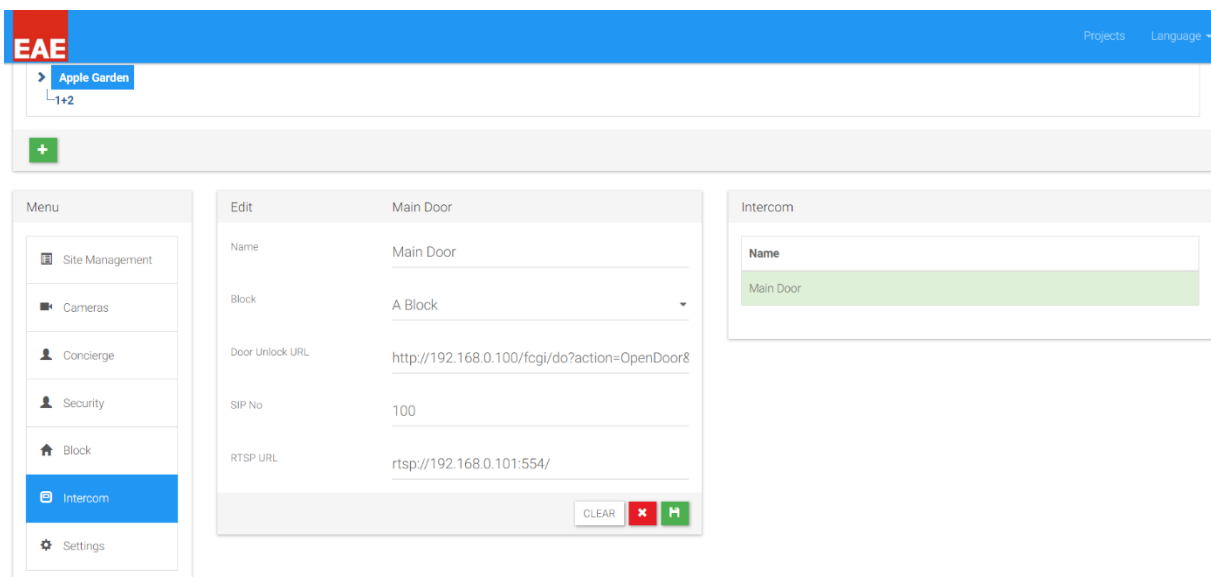

For more information refer section 3 & 4.

6.7 Configuring Apartment Type

6.7.1 Safety

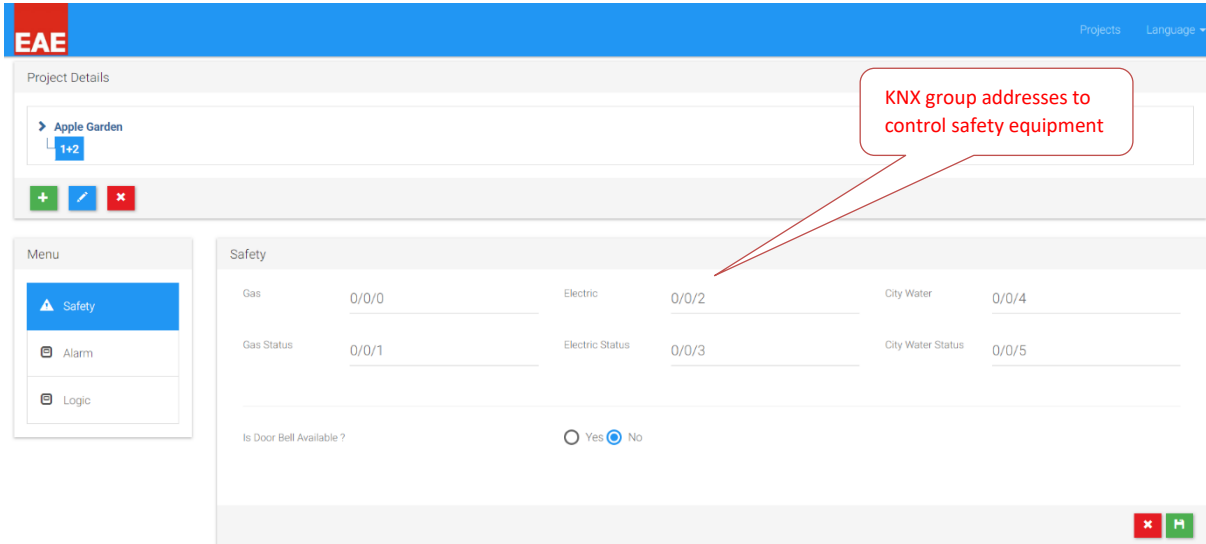

6.7.2 Alarms

Although the sequence is not important, safety alarms will be created first in this case.

There are 2 safety sensors in this project: 1 smoke detector in the kitchen and 1 flood sensor in the bathroom. These sensors short their contact line in case of an alarm. Contacts 1 & 2 on Valesa will be used for safety alarms.

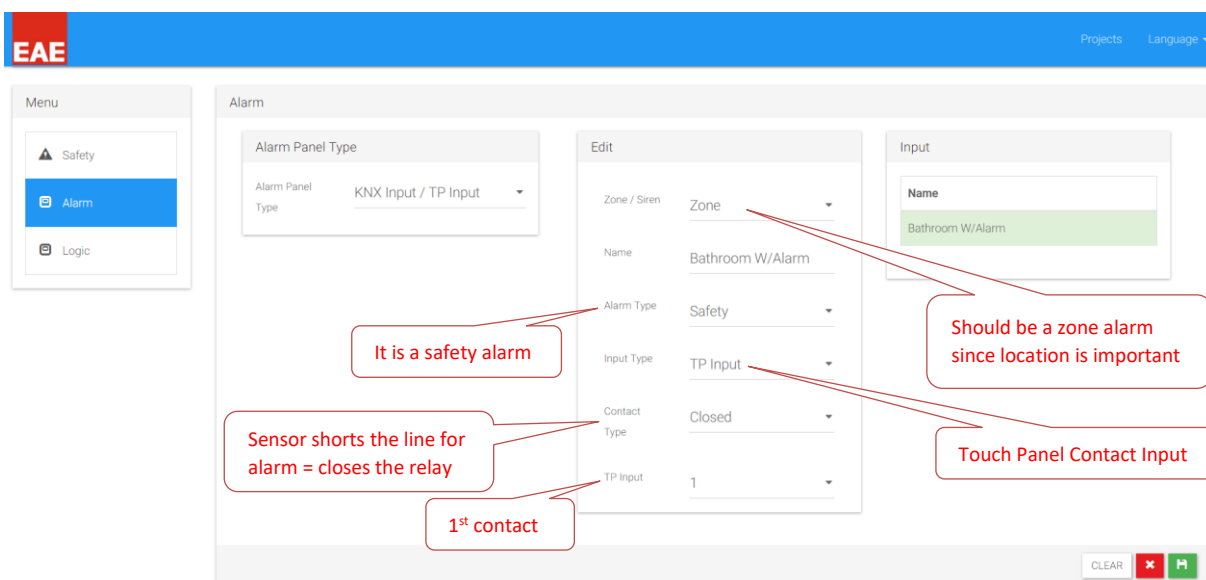

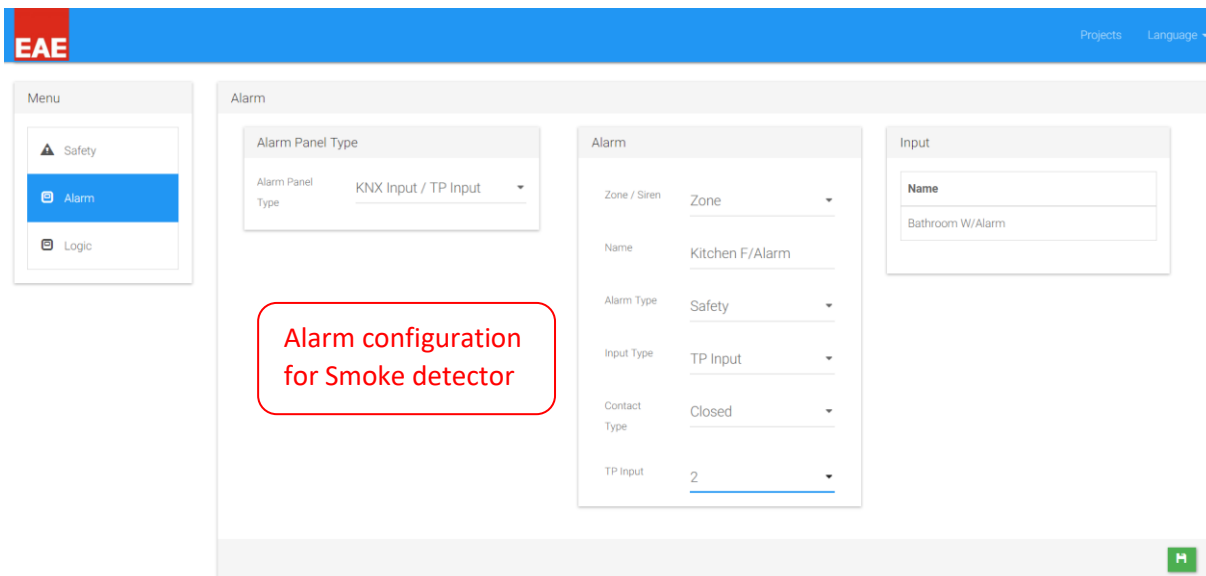

Burglar alarm configuration consists of 1 PIR sensor, 1 magnetic window contact, 1 siren in the living room and 1 magnetic contact in the bedroom window. Magnetic contacts will be TP inputs and PIR KNX input. TP inputs 3 & 4 will be used for magnetic contacts.

Logic behind the configuration is mainly the scenario of the alarm. There are two modes to arm the alarm: Stay & Away.

In stay mode, window and door magnetic contacts may be activated but the PIRs. Residents may move inside the house or sleep in unless they want to open windows whose magnetic contacts been activated in stay mode. For convenience resident is given the ability to disable zones individually. In example, bedroom window may be desired to left open when the burglar alarm is armed, and zones in subject may be disarmed (in this case bedroom window zone). This way other zones will be activated but one will able to leave desired window open.

In away mode, all the alarms including the stay mode zones will be activated. Hence, the window contacts plus PIRs will be activated. The main difference between modes; in away mode there is a 20 second delay before the alarm is armed to let the resident leave the house. Also, in case of an alarm in away mode, Valesa siren will not go off immediately. One-minute warning time is provided to enter a password and disarm the alarm. In contrast, in the case of an intrusion, armed in stay-mode, alarm will be forced to go off immediately.

For this project, door contact and PIR will be programmed in away mode. Window contacts shall be programmed in stay mode.

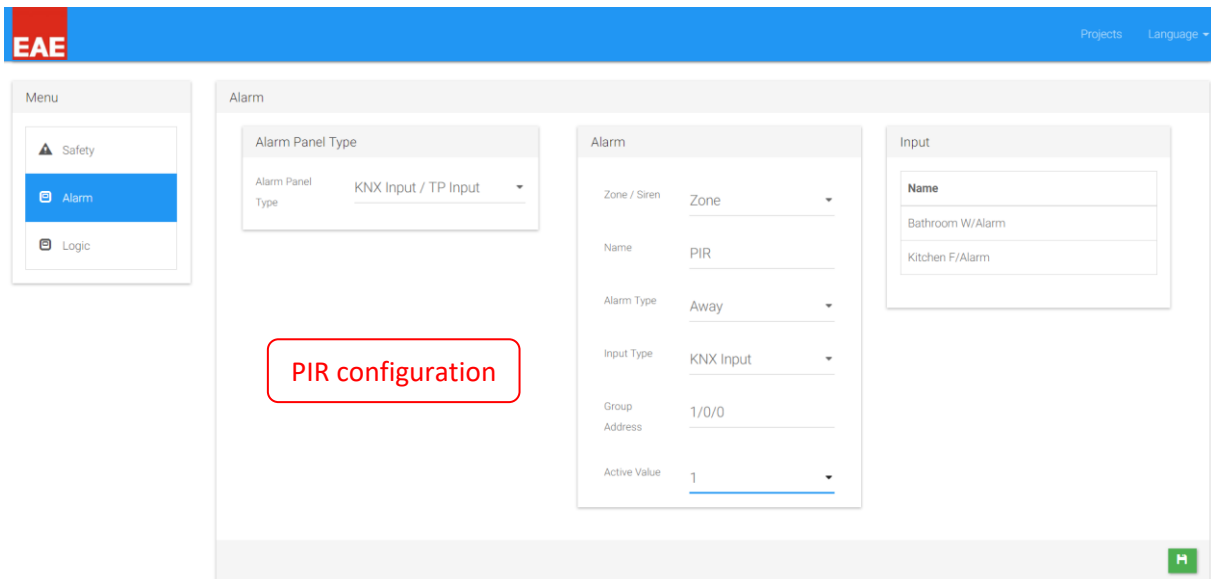

In the project, magnetic contact is normally closed when the door/window is closed. If door is open, contact output is open. Hence alarm condition occurs when contact is open.

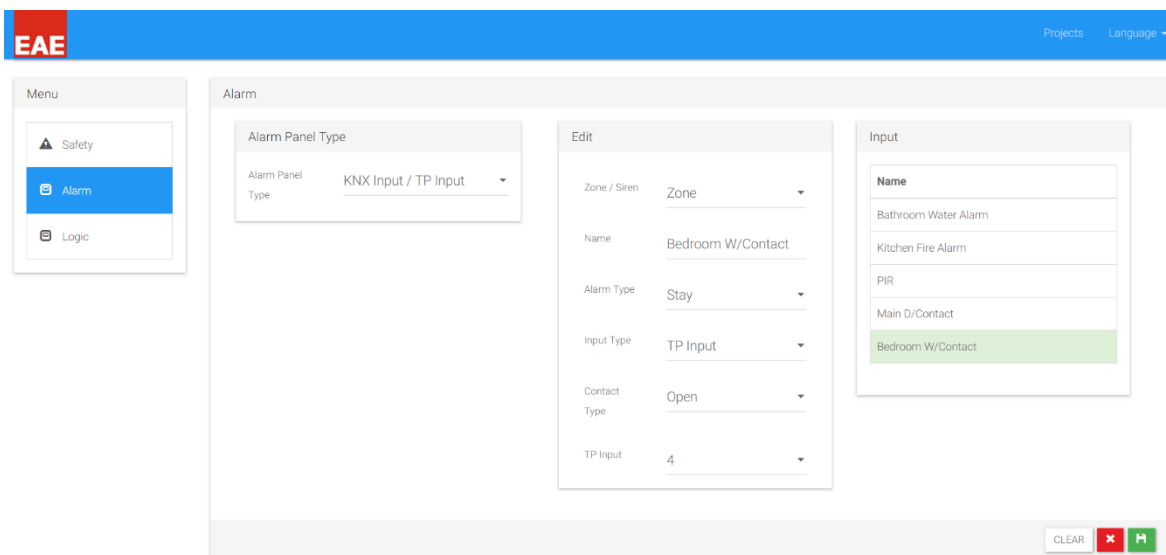
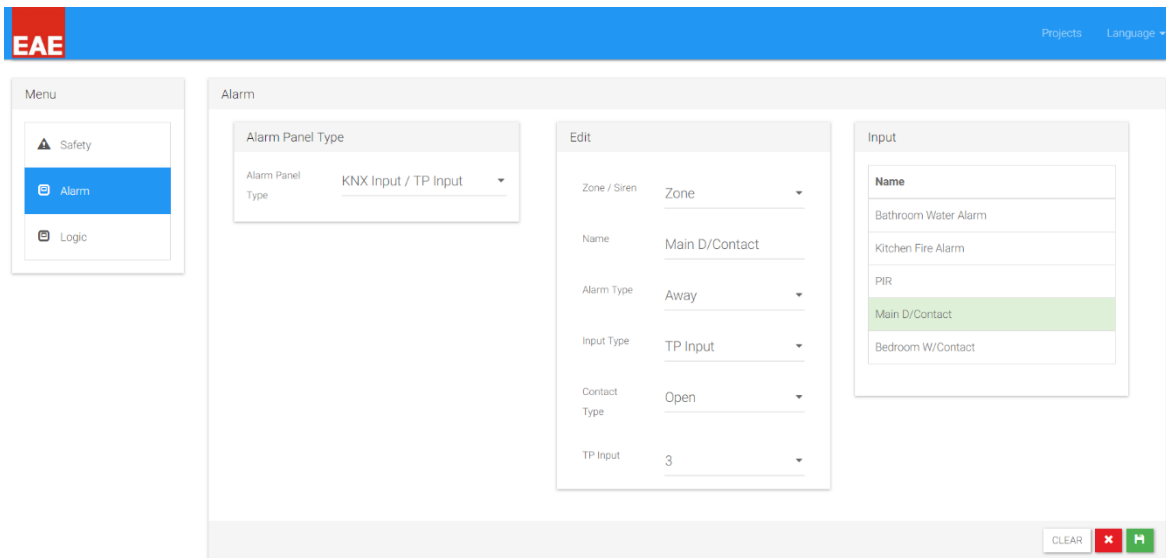

If an alarm occurs from any of the defined zones, siren will go off.

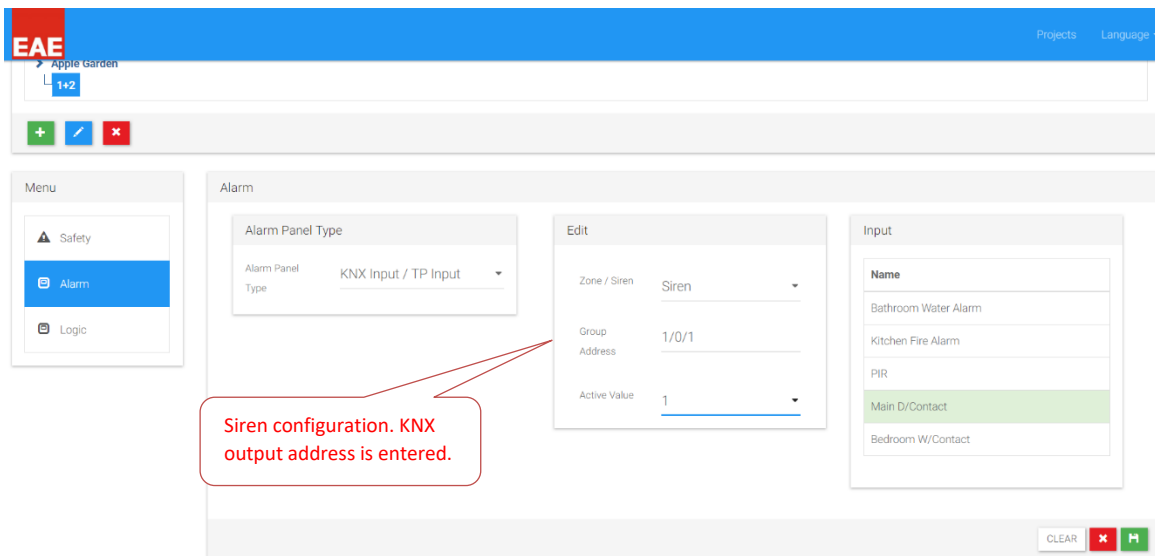

6.7.3 Logic

Residents want all the lights to be turned on if there is an intrusion to the house. KNX 1/1/1 group address is created on ETS for this application.

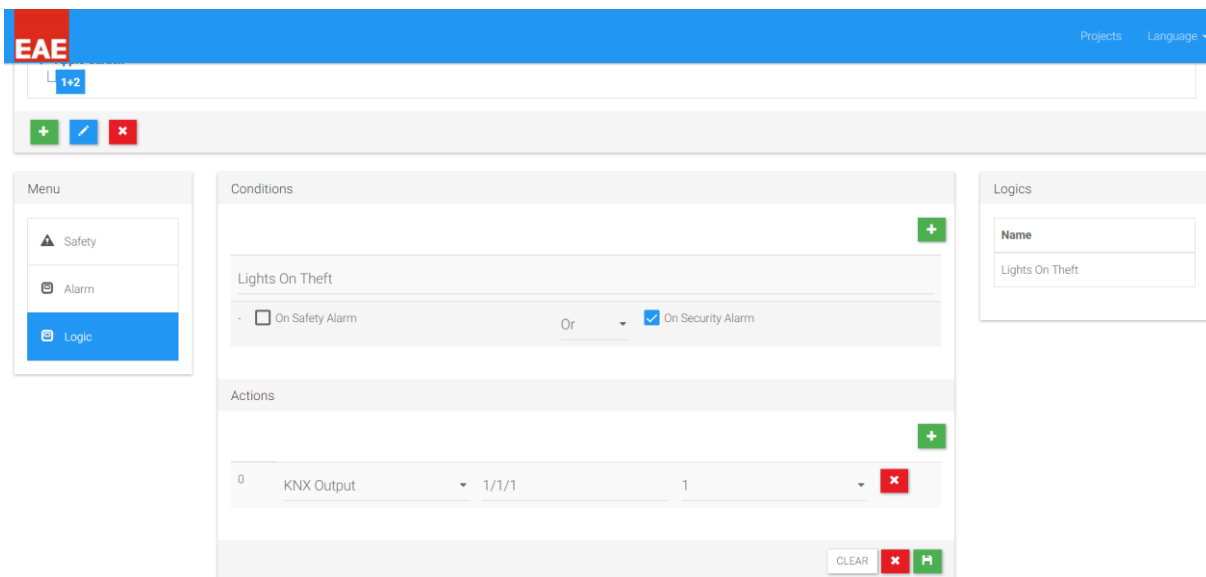

More complex logic could be added here depending on users' desire.

6.8 Creating Rooms

Based on the floor plan shown in section 6.1, following rooms must be created:

- 1 Living Room
- 1 Bedroom
- 1 Room
- 1 Kitchen
- 1 Bathroom

For more information how to create rooms refer section 3.3.

6.8.1 Lighting

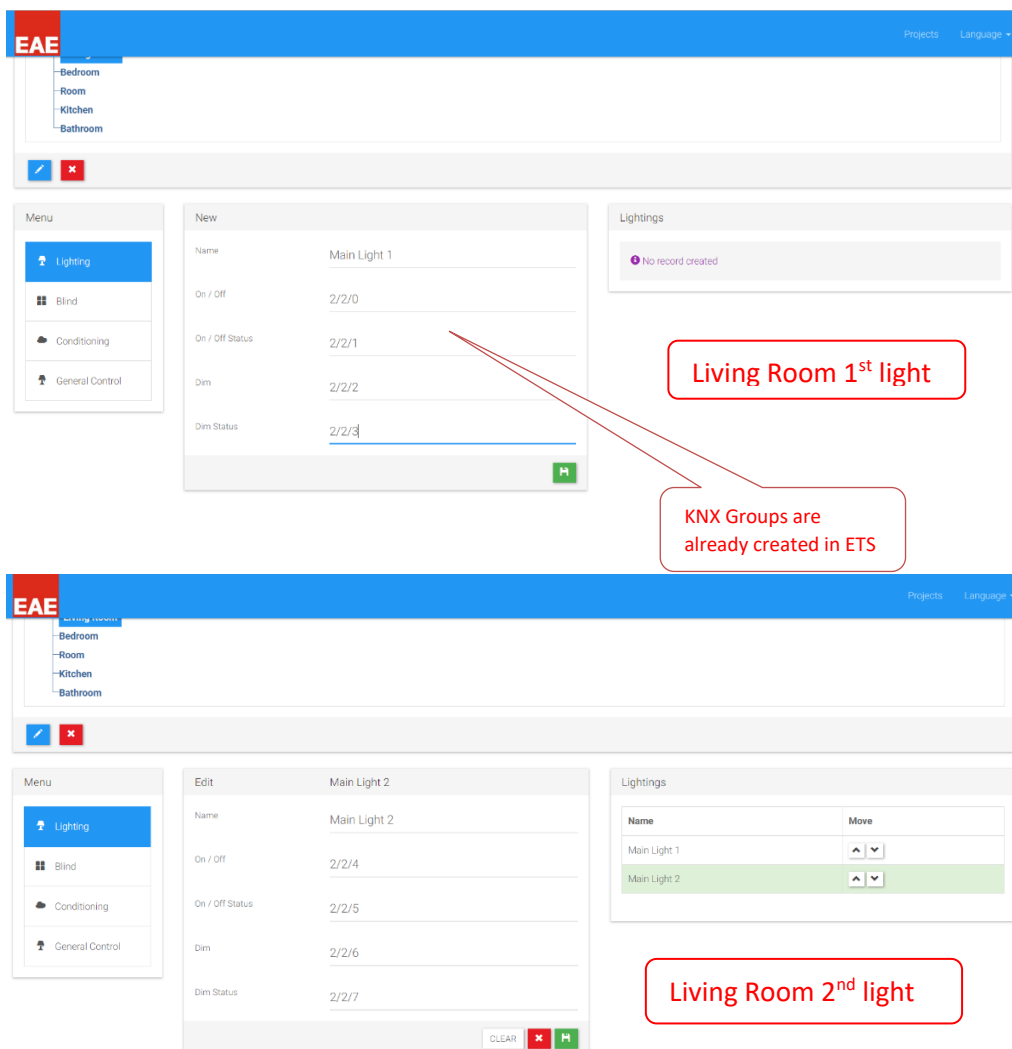

The screenshots illustrate the configuration of two main lights in the living room. The first screenshot shows the 'New' configuration window for 'Main Light 1' with the following settings:

Field	Value
Name	Main Light 1
On / Off	2/2/0
On / Off Status	2/2/1
Dim	2/2/2
Dim Status	2/2/3

The second screenshot shows the 'Edit' configuration window for 'Main Light 2' with the following settings:

Field	Value
Name	Main Light 2
On / Off	2/2/4
On / Off Status	2/2/5
Dim	2/2/6
Dim Status	2/2/7

Annotations in the screenshots indicate that the KNX Groups are already created in ETS.

Living Room 1st light

Living Room 2nd light

The screenshot shows the EAE configuration interface. At the top, there is a blue header with the EAE logo and 'Projects Language' dropdown. Below the header is a navigation tree with 'Bedroom' selected. The main area is divided into three panels: 'Menu' on the left with 'Lighting' selected; 'New' in the center, showing a form for a new light with fields for Name (Light), On / Off (2/3/0), On / Off Status (2/3/1), Dim (2/3/2), and Dim Status (2/3/3); and 'Lightings' on the right, which is currently empty with the message 'No record created'. A red box labeled 'Bedroom light' is overlaid on the right side of the interface.

The screenshot shows the EAE configuration interface. The navigation tree has 'Room' selected. The 'Edit' panel in the center shows a form for an existing light with fields for Name (Light), On / Off (2/4/0), On / Off Status (2/4/1), Dim (2/4/2), and Dim Status (2/4/3). The 'Lightings' panel on the right shows a list with one entry 'Light'. A red box labeled 'Room light' is overlaid on the right side of the interface.

The screenshot shows the EAE configuration interface. The navigation tree has 'Kitchen' selected. The 'Edit' panel in the center shows a form for an existing light with fields for Name (Light), On / Off (2/5/1), On / Off Status (2/5/2), Dim (2/5/3), and Dim Status (2/5/4). The 'Lightings' panel on the right shows a list with one entry 'Light'. A red box labeled 'Kitchen light' is overlaid on the right side of the interface.

The screenshot shows the EAE configuration interface for a Bathroom light. The top navigation bar includes the EAE logo, 'Projects', and 'Language'. A sidebar on the left lists room categories: Bedroom, Room, Kitchen, and Bathroom. The main content area is divided into three sections: a 'Menu' on the left with 'Lighting', 'Blind', 'Conditioning', and 'General Control' options; an 'Edit' table in the center; and a 'Lightings' list on the right. The 'Edit' table contains the following data:

Edit		Light
Name		Light
On / Off		2/6/0
On / Off Status		2/6/1
Dim		2/6/2
Dim Status		2/6/3

The 'Lightings' list shows a single entry: 'Light'. A red callout box labeled 'Bathroom light' points to the 'Light' entry in the list.

6.8.2 Blind

The screenshot shows the EAE configuration interface for a Living Room blind. The top navigation bar includes the EAE logo, 'Projects', and 'Language'. A sidebar on the left lists room categories: Living Room, Bedroom, Room, Kitchen, and Bathroom. The main content area is divided into three sections: a 'Menu' on the left with 'Lighting', 'Blind', 'Conditioning', and 'General Control' options; an 'Edit' table in the center; and a 'Blinds' list on the right. The 'Edit' table contains the following data:

Edit		Blind
Name		Blind
Move To Position		3/0/0
Move To Position Status		3/0/1
Move Slat		3/0/2
Move Slat Status		3/0/3

The 'Blinds' list shows a single entry: 'Blind'. A red callout box labeled 'Living Room blind' points to the 'Blind' entry in the list.

The screenshot shows the EAE configuration interface for a Bed Room blind. The top navigation bar includes the EAE logo, 'Projects', and 'Language'. A sidebar on the left lists room categories: Bedroom, Room, Kitchen, and Bathroom. The main content area is divided into three sections: a 'Menu' on the left with 'Lighting', 'Blind', 'Conditioning', and 'General Control' options; an 'Edit' table in the center; and a 'Blinds' list on the right. The 'Edit' table contains the following data:

Edit		Blind
Name		Blind
Move To Position		3/1/0
Move To Position Status		3/1/1
Move Slat		3/1/2
Move Slat Status		3/1/3

The 'Blinds' list shows a single entry: 'Blind'. A red callout box labeled 'Bed Room blind' points to the 'Blind' entry in the list.

6.8.3 Conditioning

Prior to configuring the Touch Panel conditioning section, all the relevant configurations should be made on the KNX side.

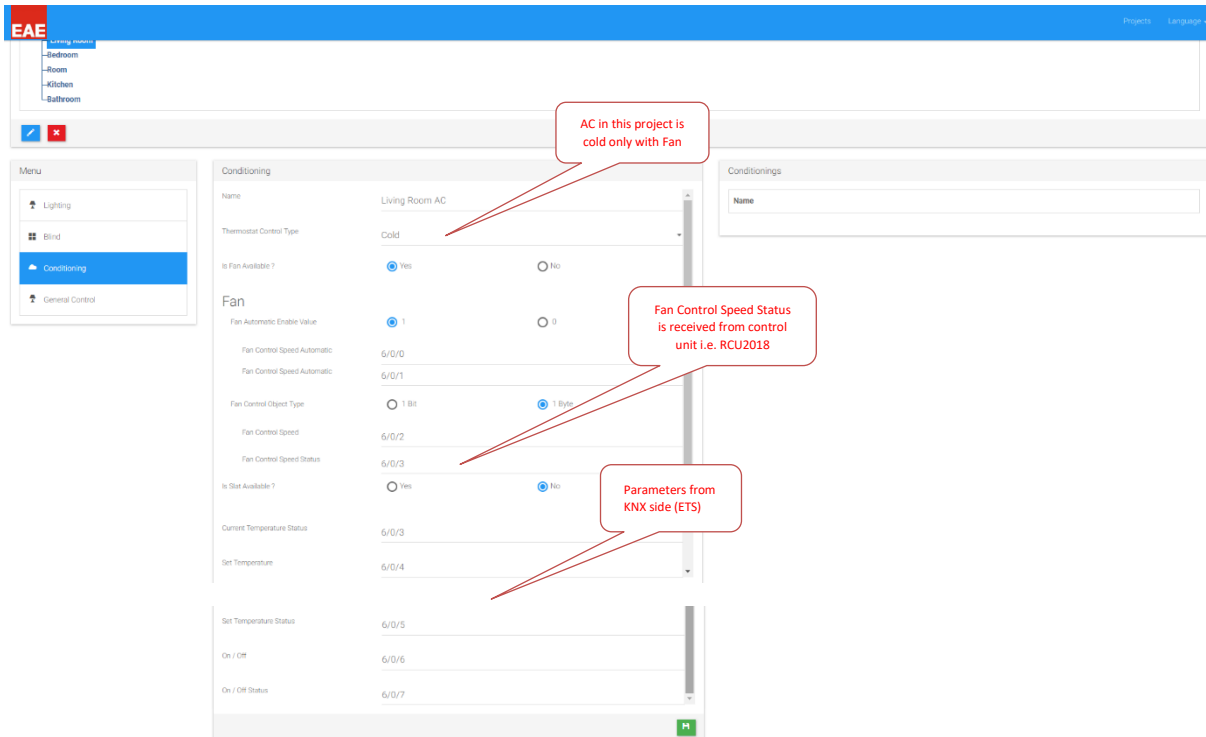

6.8.4 General Control

Resident wants to turn on/off apartment door from the touch panel. Hence General Control feature of Valesa will be used for this case. 5th touch panel output is used for this purpose. It has been added to Living Room.

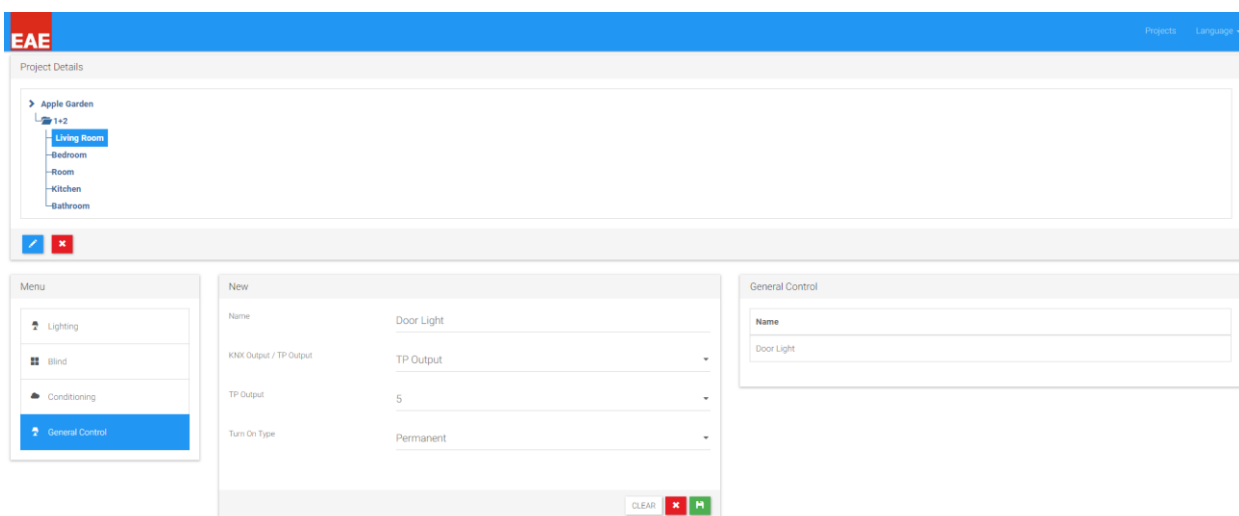

7.0 Summary

Valesa Touch Panel configuration is explained with an example in this document. One should have good knowledge in KNX to configure ETS for Valesa. For more information or any questions please contact EAE Technology: www.eaetechnology.com/