

General Description



- LC100 is able to filter the traffic according to the installation place in the bus system hierarchy or according to the built in filter tables for group oriented communication
- Galvanically isolated KNX bus lines
- Bus status (traffic, errors, filter) on each line are accurately shown by six bicolor LEDs
- LC100 supports long telegrams and features an configurable "Manual Function" that can be activated by a single button press
- Configurable one-button activation for special functions, e.g. transmit all group telegrams (useful during commissioning, automatic reset after a dedicated time, max. 8h)
- LC100 can be configured as line repeater for extending KNX lines above standard limits

Technical Data

Power supply :	- Bus	DC 21...30V SELV
	- Current consumption from KNX	< 10 mA
Connections	- KNX Main Line	Bus connection terminal
	- KNX Line	Bus connection terminal
Display elements	- LED Power	LED Error
	LED Main Line-OK	LED Sub Line-OK
	LED Main Line-RX/TX	LED Sub Line-RX/TX
	LED for programming mode	
Operating elements	- Function button, programming button	
Installation	- 35mm DIN rail mount	EN 60 715 TH 35-75
Type of protection	- IP 20	EN 60 529
Safety class	- III	IEC 61140
Degree of Pollution	- 2	IEC 60664-1
Overtoltage class	- III	IEC 60664-1
Temperature range	- Operation	-5° C + 45° C non-condensing
	- Storage	-20° C + 60° C
Humidity		%5 to 93 % no moisture condensation
Dimensions	-H x W x D	90 mm x W x 70 mm
	Width W in mm	36 mm
	Width W in units (18 mm modules)	2 modules
		Mounting depth 64 mm
Weight	62 g	
Box	Plastic PA66 housing grey	
CE	in accordance with EMC and low voltage guidelines	
	Device complies with, EN 50090-2-2, IEC 60664-1	

Connection Example

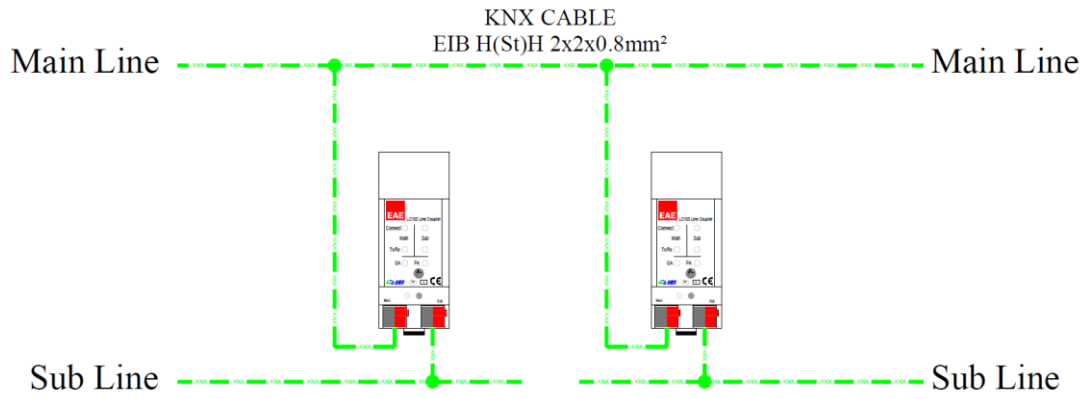

Scale Drawings

