

Room temperature controller 71 Serie

Code: EK-E72-TP-...



Datasheet STEKE72TP_EN

KNX thermostat with LC-display for the independent thermal regulation of a room or a zone. To be used in KNX installations for control of homes and buildings.



Description

The ekinex® 71 Serie room temperature controller is a KNX S-mode device for the independent temperature regulation of a room or a zone in a building. In combination with one or more KNX actuators, the room temperature controller is able to control the heating and cooling emission of a series of terminal units for the thermal exchange (such as radiators, fan-coils, floor and ceiling radiant panels, etc.). The device is provided with a LC-display with adjustable backlight and a sensor for room temperature measurement. The device is equipped with an integrated KNX bus communication module and is designed for wall installation on a flush mounting box. For the thermostat functions the integrated capacitive pushbuttons are used located on both sides of the display active area. The device is powered by the KNX bus line and does not require any auxiliary power supply.

Versions

Code	Mounting
EK-E72-TP	with Form or Flank frame
EK-E12-TP-NF	without frame ('NF Series), with black adapter
EK-E12-TP-NFW	without frame ('NF Series), with white adapter

Main functional characteristics

- Temperature measuring through integrated sensor with possibility of sending the value on the bus
- 2-point (on/off) or proportional (PWM or continuous) room temperature regulation
- Ventilation control with continuous or 3-speed regulation
- Seasonal modes: heating and cooling with possibility of local or via bus seasonal changeover
- Operating modes: comfort, standby, economy and bu-

- ilding protection with different setpoint for heating and cooling
- Manual or automatic control of fan-coil units with 2 or 4-pipes hydraulic distribution
- Displaying of measured and setpoint temperature (as °C or °F), alarms and errors (with alphanumeric coding)
- Window opening reporting

Additional functions are available receiving status or measured values via bus from other KNX devices:

- Weighted average of two temperature values
- Humidification and dehumidification control
- Automatic switching of the operating modes depending on presence or window opening
- Floor temperature limitation and antincondensation (for radiant panels)
- Antistratification function
- Automatic switching between operating modes through card holder contact
- Delayed start of a fan ("hot-start") with time-scheduling or depending on the water temperature measured at the coil for thermal exchange
- Displaying of external temperature
- Sending on the bus of the condition internal or external with regard to a configurable comfort area
- Calculation of psychrometric values (dew-point temperature and perceived temperature)
- Displaying of relative humidity (measured and setpoint in %)

Other characteristics

- Housing in plastic material
- Wall installation in flush mounting box
- Protection degree IP20 (according to EN 60529)
- Classification climatic 3K5 and mechanical 3M2 (according to EN 50491-2)
- Pollution degree 2 (according to IEC 60664-1)
- Weight 65 g (95 g with mounting support)
- Dimensions 81 x 77 x 24 mm (WxHxD)

Technical data

- Power supply 30 Vdc from KNX bus line
- Current consumption n.a.
- Power from bus n.a.

Environmental conditions

- Operating temperature: - 5 ... + 45°C
- Storage temperature: - 25 ... + 55°C
- Transport temperature: - 25 ... + 70°C
- Relative humidity: 95% not condensing

Delivery

The delivery of the room temperature controller includes a metallic support for round flush-mounting box, the fixing screws (2 pairs) and the KNX terminal block for connection of the bus line.



Note. The plate and the frame (when necessary) for the completion of the device must be ordered separately. For more information on materials, colors and finishes available, see also the ekinex® product catalog or browse www.ekinex.com

Accessories

The device is completed through a separate order of:

- a 1-fold plate (square, EK-PQS-...) or a 2-fold plate (rectangular, EK-P2G-... or EK-P2S-...) in combination with another bus device of 71 Serie or a 55 x 55 mm flush-mounting insert;
- a square frame of the ekinex® form or flank series (not for the 'NF - No Frame versions).

Plate

The pushbutton may be completed by a square 1-fold plate or by a rectangular 2-fold plate. In both cases the plate must be necessarily provided with a 60 x 60 mm window for the mounting of the device.

Plate code *	Type	Appearance	Window modularity [mm]
EK-PQS-...	1-fold **		60 x 60
EK-P2G-...	2-fold ***		55 x 55 (1) 60 x 60 (1)
EK-P2S-...	2-fold ***		60 x 60 (2)

(*) To be completed with the extension for colour, material and finishing
 (**) For mounting without frame ('NF') it requires the EK-TAQ adapter
 (***) For mounting without frame ('NF') it requires the EK-A71-... adapter

Frame

The pushbutton can be completed by a square 1-fold frame or by a rectangular 2-fold frame of the Flank or Form series. The 'NF (No Frame) versions of the pushbutton do not require any frame.

Mounting

The device has degree of protection IP20, and is therefore suitable for use in dry interior rooms. The installation of the device differs depending on the mounting with or without frame ('NF series).

Mounting with frame

Carry out the following steps:

- fix the metallic support (h) with the pair of screws (g) on the flush-mounting box (i) equipped with fixing holes at 60 mm distance;
- press for fixing the device (d) on the adapter (e);
- enter the bus terminal block, previously connected to the bus cable in its slot on the rear side (see also: "Connection of the KNX bus line"). At this point it is recommended to carry out the commissioning of the device (see also "Configuration and commissioning") or at least the download of the physical address;
- insert device and adapter (d+e) in the metallic support (h). Mounting the device follow also the indication TOP (arrow tip pointing up) on the rear side of the device;
- snap a square frame (f) of the form or flank series, inserting it from the rear of the device (d);
- fasten the device on the metallic support (h) supplied with the pair of screws (c);
- snap the front cover (b) of the device. Thanks to the reference mark on the bottom, the cover can be mounted only in the correct orientation;
- snap the plate (a).

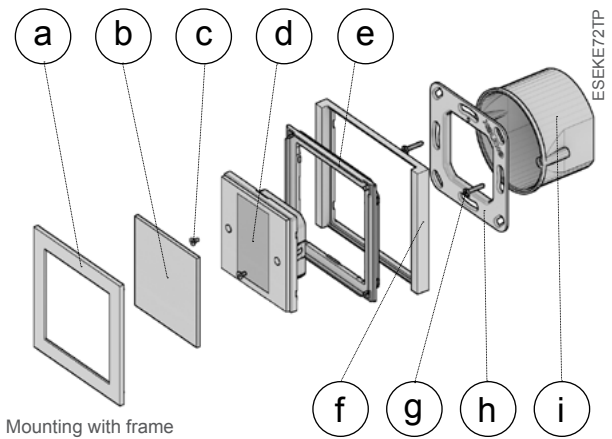

Mounting with frame

- a) Plate (with 60 x 60 mm window)
- b) front cover
- c) Fixing screws (for device)
- d) Device (Thermostat 71 Serie)
- e) Adapter for mounting without frame (delivered with the device)
- f) Frame (square, Form or Flank series)
- g) Fixing screws (for metallic support)
- h) Metallic support
- i) Flush-mounting box (not delivered by SBS)

Mounting without frame ('NF series)

Carry out the following steps:

- insert the metallic support (f) on the adapter (g);
- fix adattaper and support (f+g) with the pair of screws (e) on the flush-mounting box (h) equipped with fixing holes at 60 mm distance;
- enter the bus terminal block, previously connected to the bus cable in its slot on the rear side (see also: "Connection of the KNX bus line"). At this point it is recommended to carry out the commissioning of the device (see also "Configuration and commissioning") or at least the download of the physical address;
- insert the device (d) in the metallic support (f);
- fasten the device on the metallic support (h) supplied with the pair of screws (c);
- snap the front cover (b) of the device. Thanks to the reference mark on the bottom, the cover can be mounted only in the correct orientation;
- snap the plate (a).

If installed as single device, the room temperature controller has to be mounted on a round or square flush-mounting box with distance between fixing holes of 60 mm. If necessary, the metallic support for mounting on the wall box can also be ordered separately using the code EK-S71.

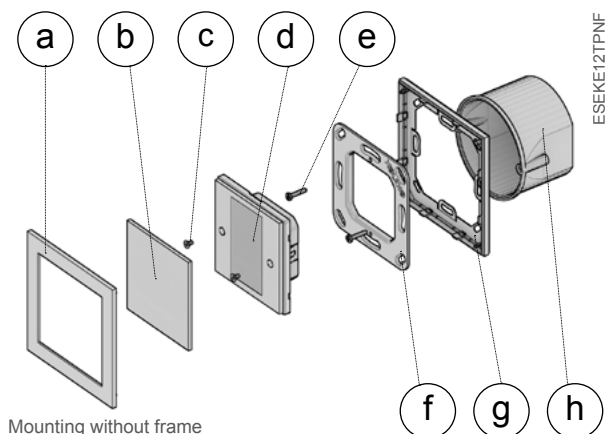

Mounting without frame

- a) Plate (with 60 x 60 mm window)
- b) front cover
- c) Fixing screws (for device)
- d) Device (Thermostat 71 Serie)
- e) Adapter for mounting without frame (delivered with the device)
- f) Frame (square, Form or Flank series)
- g) Fixing screws (for metallic support)
- h) Flush-mounting box (not delivered by SBS)

Mounting position

For an optimal temperature control the device has to be installed preferably on an inner wall of the room at a height of about 1.5 m from the floor and at least about 0.3 m from doors. The device can not be installed close to heat sources such as radiators or domestic appliances nor in positions reached by direct sunlight. If necessary, for the regulation may be used a weighted average between the value measured by the integrated sensor and the value received via bus by another KNX device (e.g. by ekinex pushbuttons).

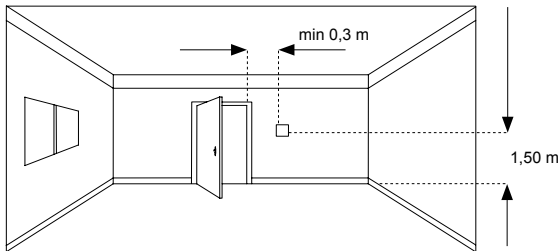

Switching, connection and display elements

The device is provided with a programming pushbutton and a programming LED, four capacitive pushbuttons and a backlighted LC-display.

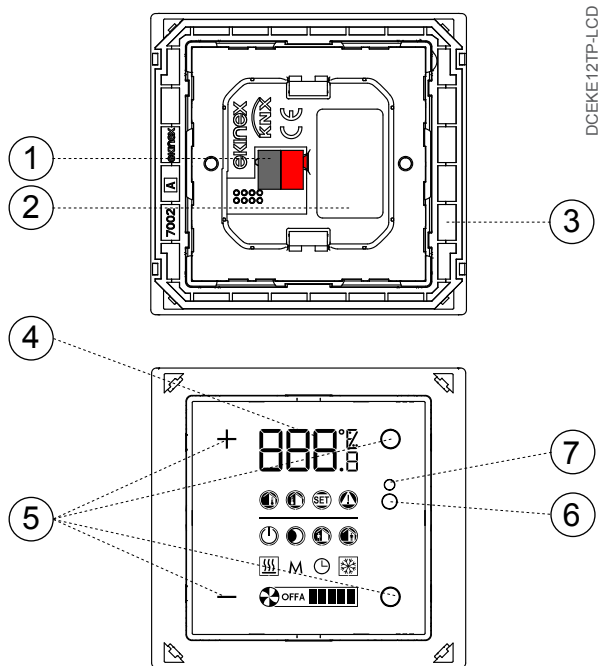

- 1) Terminal for bus line connection
- 2) Label
- 3) Adapter
- 4) LC-Display
- 5) Capacitive pushbuttons
- 6) Programming pushbutton
- 7) Programming LED

Switching elements

- Pushbutton (6) for switching between the normal and programming operating modes
- Four capacitive pushbuttons (5) for room thermostat functions

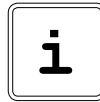

Note. Programming pushbutton and LED are accessible from the front side of the device. The device addressing may be easily carried out before the mounting of cover, plate and frame. Once the addressing has been carried out, the device configuration can be later downloaded without pressing the programming pushbutton.

Display elements

- LC-display (4) with digits and symbols for displaying the operating conditions of the device
- Red LED (7) for indication of the active operating mode (on = programming, off = normal operation)

Connection of the KNX bus line

The connection of the KNX bus line is made with the terminal block (black/red) included in delivery and inserted into the slot of the housing.

Characteristics of the KNX terminal block

- spring clamping of conductors
- 4 seats for conductors for each polarity
- terminal suitable for KNX bus cable with single-wire conductors and diameter between 0.6 and 0.8 mm
- recommended wire stripping approx. 5 mm
- color codification: red = + (positive) bus conductor, black = - (negative) bus conductor

Configuration and commissioning



Warning! In order to supply the KNX bus lines use only KNX bus power supplies (e.g. ekinex EK-AB1-TP or EK-AG1-TP). The use of other power supplies can compromise the communication and damage the devices connected to the bus.

KNX bus
+
-

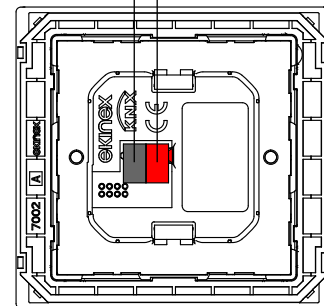

Warning! The electrical connection of the device can be carried out only by qualified personnel. The incorrect installation may result in electric shock or fire. Before making the electrical connections, make sure the power supply has been turned off.

Configuration and commissioning of the device require the use of the ETS® (Engineering Tool Software) program V4 or later releases. These activities must be carried out according to the design of the building automation system done by a qualified planner.

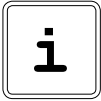

Note. The configuration and commissioning of KNX devices require specialized skills. To acquire these skills, you should attend the workshops at KNX certified training centers.

Configuration

For the configuration of the device parameters the corresponding application program or the whole ekinex® product database must be loaded in the ETS program. For detailed information on configuration options, refer to the application manual of the device available on the website www.ekinex.com.

Code	Application program (## = release)	Comm. objects (max nr.)	Group addr. (max nr.)
EK-E72-TP	APEKE72TP##.knxprod	n.d.	n.d.

Commissioning

For commissioning the device the following activities are required:

- make the electrical connections as described above;
- turn on the bus power supply;
- switch the device operation to the programming mode by pressing the programming pushbutton located on the front side in the area for the mounting of the rockers. In this mode of operation, the programming LED is turned on;
- download into the device the physical address and the configuration with the ETS® program.

At the end of the download the operation of the device automatically returns to normal mode; in this mode the programming LED is turned off. Now the bus device is programmed and ready for use.

Dimensions [mm]

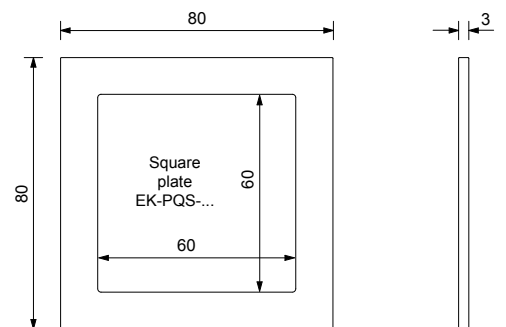
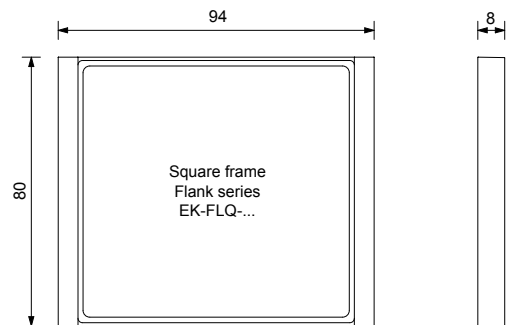
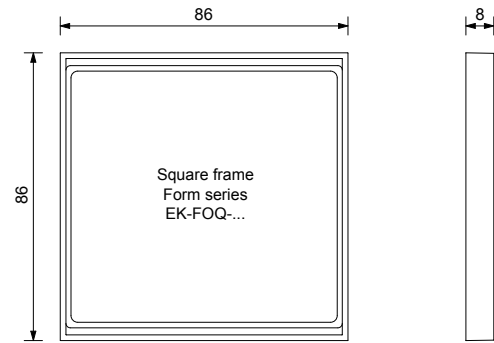
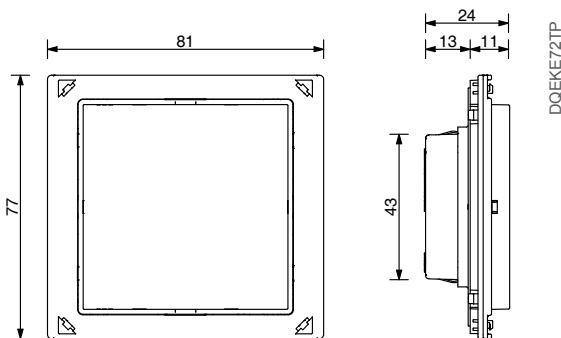

Marks

- KNX
- CE: the device complies with the Low Voltage Directive (2006/95/EC) and the Electromagnetic Compatibility Directive (2004/108/EC). Tests carried out according to EN 50491-5-1:2010, EN 50491-5-2:2010

Maintenance

The device is maintenance-free. To clean use a dry cloth. It must be avoided the use of solvents or other aggressive substances.

Disposal



At the end of its useful life the product described in this datasheet is classified as waste from electronic equipment in accordance with the European Directive 2002/96/EC (WEEE), and cannot be disposed together with the municipal undifferentiated solid waste.



Warning! Incorrect disposal of this product may cause serious damage to the environment and human health. Please be informed about the correct disposal procedures for waste collecting and processing provided by local authorities.

Documentation

This datasheet refers to the release A1.0 of the ekinex® device EK-E72-TP-..., and is available for download at www.ekinex.com as a PDF (Portable Data Format) file.

File name	Device release	Updating
STEKE72TP_IT.pdf	A1.0	12 / 2015

Warnings

- Installation, electrical connection, configuration and commissioning of the device can only be carried out by qualified personnel in compliance with the applicable technical standards and laws of the respective countries
- Opening the housing of the device causes the immediate end of the warranty period
- In case of tampering, the compliance with the essential requirements of the applicable directives, for which the device has been certified, is no longer guaranteed
- ekinex® KNX defective devices must be returned to the manufacturer at the following address: SBS S.p.A. Via Circonvallazione s/n, I-28010 Miasino (NO) Italy

Other information

- This datasheet is aimed at installers, system integrators and planners
- For further information on the product, please contact the ekinex® technical support at the e-mail address: support@ekinex.com or visit the website www.ekinex.com
- Each ekinex® device has a unique serial number on the label. The serial number can be used by installers or system integrators for documentation purposes and has to be added in each communication addressed to the SBS technical support in case of malfunctioning of the device
- ekinex® is a registered trademark of SBS S.p.A.
- KNX® and ETS® are registered trademarks of KNX Association cvba, Brussels

© SBS S.p.A. 2015. The company reserves the right to make changes to this documentation without notice.