

ekinex

CONTROL YOUR LIVING SPACE



Application Manual EK-HH1-TP Mixing group controller

Summary

1	Scope of the document.....	5
2	Product description.....	6
2.1	General characteristics.....	6
2.2	Electrical characteristics.....	8
3	Switching, display and connection elements.....	9
4	Configuration.....	11
5	Programming and commissioning.....	11
6	Function description.....	12
6.1	Switching on.....	12
6.2	Offline operation.....	12
6.2.1	Operation with bus power only.....	12
6.2.2	Operation with load power supply only.....	12
6.3	Manual operation.....	12
6.3.1	Output status when mode changes.....	12
6.3.2	Manual mode activation.....	13
6.4	Online operation.....	13
6.4.1	Software working cycle.....	13
6.4.2	State variables (communication objects).....	13
6.5	Applications.....	13
6.6	Mixing group management.....	14
6.6.1	Components.....	14
6.6.2	Activation/deactivation sequence.....	14
6.6.3	Activation.....	14
6.6.4	Heating/cooling changeover.....	15
6.6.5	Types of supported servomotors.....	15
6.6.6	PI (proportional-integral) regulator.....	16
6.6.7	Circulator protection function.....	16
6.6.8	Anticondensation protection function.....	16
6.6.9	Alarms.....	17
6.7	Physical inputs.....	20
6.8	Physical outputs.....	20
6.9	Control modes.....	21
6.9.1	Heating: fixed point.....	21
6.9.2	Heating: climatic compensation.....	21
6.9.3	Heating: recalibration based on return temperature.....	22
6.9.4	Heating: recalibration based on internal conditions.....	23
6.9.5	Heating: climatic compensation and recalibration based on internal conditions.....	24
6.9.6	Heating: connecting communication objects of KNX sensors.....	25
6.9.7	Cooling: fixed point.....	27
6.9.8	Cooling: climatic compensation.....	27
6.9.9	Cooling: recalibration based on internal thermohygrometric conditions.....	28
6.9.10	Cooling: clim. Comp. and recalibration based on internal thermohygrometric conditions.....	28
6.9.11	Cooling: connecting communication objects of KNX sensors.....	29
7	Display.....	32
7.1	Navigation buttons.....	32

7.2	Navigation menus	32
8	Application program for ETS	34
8.1	About EK-HH1-TP.....	34
8.2	General parameters	35
8.3	Inputs	39
8.4	External sensors from bus	43
8.5	Heating.....	46
8.6	Cooling.....	50
8.7	Mixing valve output	54
8.8	Logic functions	57
9	Appendix.....	60
9.1	List of KNX communication objects	60
9.2	Retained communication objects.....	64
9.3	Error indications	65
9.4	Application examples	67
10	Warnings.....	72
11	Other information.....	72

Revision	Modifications	Date
1.00	Emission	07/04/2017

1 Scope of the document

This application manual describes application details for the A1.0 release of the ekinex® controller EK-HH1-TP.

The document is aimed at the system configurator as a description and reference of device features and application programming. For installation, mechanical and electrical details of the device please refer to the technical description datasheet.

Application manual and application programs for ETS are available for download at www.ekinex.com.

<i>Item</i>	<i>File name (## = release)</i>	<i>Version</i>	<i>Device rel.</i>	<i>Update</i>
Technical datasheet	STEKHH1TP##_IT.pdf	EK-HH1-TP	A1.0	04/2017
Application manual	MAEKHH1TP##_IT.pdf		A1.0	04/2017
Application program	APEKHH1TP##_knxprod		A1.0	04/2017

You can access the most up-to-date version of the full documentation for the device using following QR code:

EK-HH1-TP



2 Product description

The ekinex® controller EK-HH1-TP is a KNX device for DIN-rail mounting designed to control a mixing group of a radiant or ceiling radiant plant in heating/cooling applications. A mixing group control includes a modulation of the mixing valve position and start/stop of the circulator of the related hydraulic circuit. The device is equipped with analog inputs for supply and return temperature of the heating fluid, and external temperature, according to the selected operating mode. Two inputs are also available for monitoring temperatures and status of the thermal plant and two outputs for auxiliary commands such as start/stop of high temperature circulators for radiators or fancoils) or consensus to servomotors for zone valves.

To control a mixing valve, a 3 point floating servomotor with 230Vac or 24Vac power supply can be used, or a servomotor with high impedance 0-10V control signal. The device can be used as standalone with activation and heating/cooling changeover through input contacts. Alternatively, the device can communicate with up to 16 sensors or KNX room thermostats (with temperature, or temperature and relative humidity detection) and integrate the primary thermal plant regulation and the secondary room regulation: switching on and off the system and the optimal delivery temperature are automatically selected based on real internal conditions of the building; in cooling applications, it is also possible to select the optimal delivery temperature as an active protection in order to avoid surface condensation.

The product is equipped with a membrane keyboard and a text display to manually control its outputs, monitor all temperatures and plant status and modify some operating parameters. LEDs indicators provide information about the inserted manual mode and allow a quick diagnosis of communication and plant alarms.

The device is equipped with an integrated communication module for KNX bus and it is suitable for 35mm DIN-rail mounting, compliant to EN 60715. The power of the logic side is supplied by KNX bus (SELV, 30Vdc); the power of display and relay outputs is supplied by network voltage 230Vac, 50-60 Hz; moreover, in order to control a 3 point floating servomotor, terminal blocks for auxiliary network power supply at 230 Vac or 24 Vac, 50/60 Hz are made available.

The complete supply includes:

- A device;
- A terminal block for KNX bus line;
- An instruction sheet.

2.1 General characteristics

General functional characteristics:

- 1 mixing valve control, with 3 point floating servomotor with 230Vac or 24Vac power supply, or 0-10V control signal
- Start/stop command of the mixing group circulator
- Overheating and undercooling alarm management on delivery temperature of the mixing group, protecting screed and coating
- 2 relay outputs for auxiliary control functions
- 3 analog inputs for passive temperature sensors (NTC at 10 kΩ at 25°C) for supply, return and external temperature acquisition
- 2 inputs freely programmable as digital or analog (e.g. for anticondensation probe or flow request contact)
- Mixing group activation through input contact, via bus (flow requests of max. 16 sensors or KNX room thermostats) or via a combination of former and latter.
- Heating/cooling changeover through input contact, from bus or manual changeover from the device's alphanumeric display

- Mixing group protection function (circulator protection) during long inactivity periods
- 2 channel and 16 input per channel logic functions, in order to realize combinatory logics for building automation through AND, OR, NOT and XOR blocks, with delayed activation of the corresponding output
- Monitoring of the operating variables through alphanumeric display, in order to make commissioning easier
- Modification of subset of control parameters through alphanumeric display and membrane keyboard

Configurable control modes:

Conduction mode	Activation	
	From input contact	From bus or From input contact or from bus
Heating	<ul style="list-style-type: none"> ▪ Fixed point ▪ Climatic compensation ▪ Recalibration on return temperature 	<ul style="list-style-type: none"> ▪ Fixed point ▪ Climatic compensation ▪ Recalibration on return temperature ▪ Recalibration on internal conditions ▪ Climatic compensation and recalibration on internal conditions
Cooling	<ul style="list-style-type: none"> ▪ Fixed point ▪ Climatic compensation 	<ul style="list-style-type: none"> ▪ Fixed point ▪ Climatic compensation ▪ Recalibration on internal thermoigrometric conditions ▪ Climatic compensation and recalibration on thermoigrometric internal conditions



The control with KNX devices, even when properly configured and commissioned, cannot cope to the undersizing or oversizing of thermal generators, distribution network and environment terminals.



The proper selection of the control mode and its proper parametrization must be evaluated together with the plant designer, taking into account all adopted plant solutions.

2.2 Electrical characteristics

Product code	EK-HH1-TP
Logic side power supply (microcontroller)	from KNX bus (30 Vdc)
Auxiliary network power supply (display backlight and relay control)	230 Vac
Auxiliary additional network power supply (3 floating point servomotor)	24 Vac / 230 Vac
2 triac output for 3 floating point servomotor control	1 A / 250 Vac
1 0-10 V output for servomotor control	For high impedance input
3 relay outputs for circulator control and additional commands	monostable, 10(5) A / 250 Vac
3 analog inputs for passive temperature sensors	NTC, 10 kΩ at 25°C
2 freely programmable inputs	Free contact binary inputs or NTC, 10 kΩ at 25°C analog inputs
Current consumption from bus	< 30 mA
Operating temperature	0°C... +45°C
Protection degree	IP20
Size	144 x 90 x 60 mm (L x H x P)

3 Switching, display and connection elements

The front side of the EK-HH1-TP device is fitted with a 4-key membrane keyboard, 2 indication LEDs, a 16 x 2 lines alphanumeric display and terminal blocks. The membrane keys allow the selection of different display menus and parameter modification: for an extended description of these menus and selectable parameters please refer to the chapter about the display functions.

When switching the device in manual mode, by acting on dedicated display menu it is possible to activate the device's outputs; this allows testing the system. On the front side there is also a pushbutton for programming mode activation with relative LED and the terminals for connecting the KNX bus line.

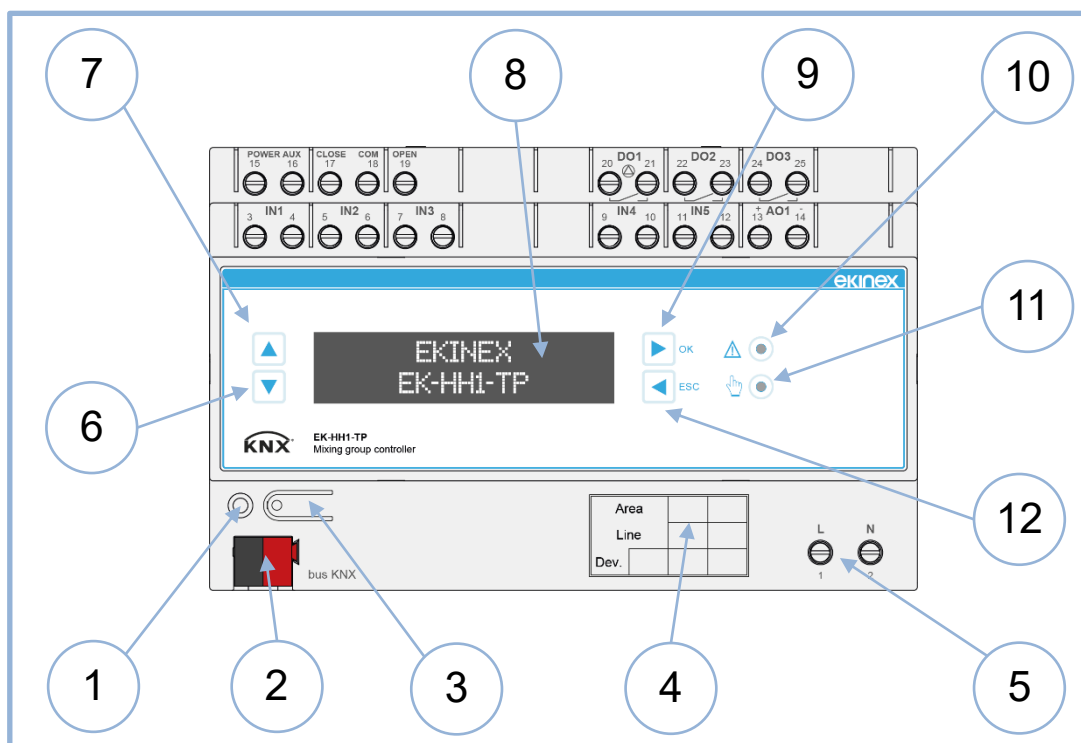





Figure 1 - Switching, display and connection elements controller EK-HH1-TP

1. Programming LED	8. Alphanumeric 2 lines x 16 columns backlighted display
2. Terminal block for KNX bus line	9. CONFIRM pushbutton
3. Programming pushbutton	10. LED indicator for alarm
4. Physical address writing fields	11. LED indicator for manual mode active
5. Terminal blocks (1-2) for 230 Vac power supply connection	12. RETURN pushbutton
6. Pushbutton for menu scrolling downwards	
7. Pushbutton for menu scrolling upwards	

Indication LEDs

LED	Meaning
 	Alarm active (*)
 	Output manual status operation (**)

(*) This LED indicates the presence of an alarm; alarms are all with automatic reset. Please refer to the display dedicated page to verify the updated list of active alarms.

(**) Manual mode insertion is carried out through the display dedicated menu.

4 Configuration

The exact functionality of the device depends on the ETS (Engineering Tool Software) software settings. In order to configure and commission the device you need ETS4 or later releases and the ekinex® application program, APEKHH1TP##.knxprod (## = version), which can be downloaded from the ekinex website www.ekinex.com. The application program allows the configuration, from ETS, of all working parameters for the device. The device-specific application program has to be loaded into ETS or, as alternative, the whole ekinex® product database can be loaded; at this point, all the instances of the selected device type can be added to the project. Configurable parameters are described in details in the next chapters of this application manual.

Product code	EAN	No. of channels	ETS application software (## = release)	Communication objects (max no.)	Group addresses (max no.)
EK-HH1-TP	8018417219146	-	APEKHH1TP##. knxprod	183	254



Configuration and commissioning of KNX devices require specialized skills; to acquire these skills, you should attend training courses at a training center certified by KNX.

For further information: www.knx.org.

5 Programming and commissioning

After the device has been configured within the ETS project according to user requirements, the commissioning of the device requires the following activities:

- electrically connect the device, as described in the product datasheet, to the bus line on the final network or through a purposely setup network for programming;
- apply power to the bus;
- switch the device operation to programming mode by pressing the programming pushbutton located on the rear side of the housing. In this mode of operation, the programming LED is turned on steady;
- upload the configuration (including the physical address) to the device with the ETS program.

At the end of the upload, the operation of the device automatically returns to normal mode; in this mode the programming LED is turned off. Now the device is programmed and ready for use on the bus.

6 Function description

6.1 Switching on

After connecting the bus line, the device becomes fully functional after a short time (tenths of ms) needed for reinitialization. A delay is programmable for the device to become active on the bus in order to avoid a bus traffic overload during the first moments of start-up of the whole network.

6.2 Offline operation

The device will not be functional in case the KNX bus line should be missing.

The internal circuit dedicated to logic, control and communication is powered by KNX bus line; alphanumeric display and output loads, for consumption reasons, are powered by auxiliary supply only.

Should bus supply be off, the device will be completely not functional.

6.2.1 Operation with bus power only

In case of missing main power supply, relay outputs (DO1, DO2 e DO3) open (coil not active). Triac outputs require an auxiliary external power supply, therefore if that power is missing the connected servomotor remains in the last position reached when power was present.

In order to detect this normally undesired situation, it is possible to enable a communication object which activates an alarm, so that other devices on the bus can take all proper countermeasures and/or display the anomaly to the user.

6.2.2 Operation with load power supply only

When KNX bus is disconnected, or in case of bus voltage failure (voltage less than 19 V for more than 1 s), all device functions are stopped, and triac outputs are closed.

When the power is restored, the device will resume operation in its previous state (which is saved on power fail), unless different initialization settings are programmed (for mixing group servomotor control).

6.3 Manual operation

Manual operation constitutes an alternative to input switching through bus commands or internal logic; this mode is meant for test, commissioning or maintenance only.

6.3.1 Output status when mode changes

When manual mode is activated, outputs' status are all non active. When manual mode is active, the frames coming from the bus do not affect the physical outputs; the output contacts can be switched only through the proper LCD menu.

The manual activation/deactivation of the outputs does not generate any feedback frame.

From another point of view, the situation could be explained by saying that during manual mode it is like the variables were temporarily "unconnected" from group addresses. When "reconnecting" them (exit from manual mode) their value remains unaltered until a new command from bus does not alter them.

The same considerations made for the command from bus are valid for state changes caused by internal timing functions (e.g. activation delays): those state changes have no effect while manual mode is active.

6.3.2 Manual mode activation

The EK-HH1-TP device is fitted with a display dedicated menu to manually activate outputs. Similarly, the manual command of the single output is carried out through the dedicated menus.

6.4 Online operation

All functions described below presume that the device has been correctly configured with ETS. An unprogrammed device does not perform any task on the bus; however, it can be activated through the membrane keyboard, making it switch to manual mode.

6.4.1 Software working cycle

The tasks performed by the software are the following:

- update the internal state variables based on KNX frames;
- implement the functions related to timing and other integrated functions to determine the state of the outputs;
- answer to the requests related to the communication objects received via bus

In addition, there are particular events that can trigger additional features. These events are, for example, a bus power failure or restore, or an ETS new configuration load.

6.4.2 State variables (communication objects)

The device status, with particular attention to its interface elements (outputs) is based on *state variables* which are automatically defined by the application program. When a state variable is assigned to a group address, this variable automatically becomes a KNX communication object; therefore, it inherits all the usual characteristics of communication objects, such as the use of *flags* to determine the impact of the object modification on its bus transmission.

6.5 Applications

The EK-HH1-TP controller manages 1 mixing group for floor or ceiling radiant plants, both during cooling and heating, in combination with generators such as condensation boilers, chillers or heat pumps, in particular when 2 temperature connections are needed, a low temperature for radiant plant and a medium or high temperature for radiators or towel heaters.

The device can be used as standalone or integrated in a KNX network. Ideal applications for this device, integrated inside an automation system, are about:

- Residential or service buildings with radiant systems: mixing group management inside a technical compartment, control of auxiliary circulators and/or zone valves
- Apartments in condos with centralized thermal generation: thermal module with mixing group management, temperature connections for fancoil or dehumidifiers and intercept zone valves
- Heating plants with radiators with connections inside the thermal plant, equipped with a mixing valve

6.6 Mixing group management

6.6.1 Components

The mixing group to which this application manual refers is made by the following components:

- Mixing valve
- Servomotor paired to the mixing valve
- Circulator after the valve
- Immersion delivery sensor
- Safety immersion delivery sensor

Please refer to the Application example in the Appendix for further information about the wiring schemes of these components. This component list can be completed by other sensors (immersion return sensor and outside temperature sensor), based on the selected control mode and type of monitoring that must be carried out inside the technical compartment of the mixing group.

6.6.2 Activation/deactivation sequence

The controller runs the activation/deactivation sequence of the mixing group. Its execution steps are:

1. Boot after shutdown and reboot of the control unit with full positioning bypass cycle of the mixing valve
2. Wait for the reset cycle to complete
3. Wait for a system activation request
4. Wait for the boot cycle to complete. If, for example, the ON state of a room thermostat controls, through a power module, some electrothermal actuators, it will be necessary to wait their aperture in order to prevent the circulator head from pushing against closed circuits.
5. Normal operation with valve modulation and circulator ON.
6. Wait for possible temperature alarms (overtemperature during heating or undertemperature during cooling)
7. When an overtemperature or undertemperature alarm is active, wait for the heat/refrigeration disposal cycle before returning to normal operation (4 minutes)
8. Alarm lock with automatic reset if the plant does not dispose of heat or refrigeration in excess

The idle position, in absence of flow requests, causes the mixing valve to fully close in order to avoid leakages from the generator direct pipe, and circulator OFF.

The bypass position during boot phase, after the KNX bus has been powered on, is useful in case of 3 point floating servomotor: this positioning allows the valve position to be calibrated, as well as verifying the correct electrical wiring.



After device boot or when an activation ends, a reset cycle runs. Every other activation is only effective when the ongoing reset cycle is complete. Please refer to the display menu *Monitoring* to know the controller's actual state.

6.6.3 Activation

The EK-HH1-TP controller is fitted with flexible configuration modes, depending on the adopted plant solution and complexity of the KNX device architecture. A mixing group can be activated in one of the following ways:

- From binary input

- From bus
- From binary input and from bus

An activation from binary input is suitable to standalone applications where there is no integration between main central and room secondary regulation. With this setting, the IN4 input is automatically configured as a binary voltage-free contact: the output of a time scheduler can be connected to it, in order to activate an hourly schedule or an enabling contact from a standalone room thermostat; alternatively, it is common practice in radiant floor systems to connect in parallel limit switches of electrothermal actuators installed on distribution manifolds.

By activating the mixing group from bus, the system exposes to communication objects to connect up to 16 flow requests from room controllers integrated in the KNX networks. The controller automatically executes a logic OR of the flow requests: if at least one room controller asks for flow, the mixing group activates. An intermediate solution can be activating the mixing group both from binary input and from bus: the binary input can be priority on the flow requests coming from bus (e.g. an external time scheduling device) or can act as an additional zone (without priority).

Disregarding the selected mode, it is possible to set an activation delay with range 1 – 255 s in order to start the mixing: if, for example, the communication objects of flow requests from the zones are connected, it is useful to wait that the electrothermal actuators open their circuits in order to avoid the circulator from pushing against hydraulically closed circuits.

6.6.4 Heating/cooling changeover

Changeover between heating and cooling can be configured via ETS in one of the following ways:

- From binary input
- From bus
- From display

An activation from binary input is suitable to standalone applications where there is no integration between main central and room secondary regulation. With this setting, the IN5 input is automatically configured as a binary voltage-free contact: usually it can be connected an external selector used inside the technical compartment in order to switch the operating mode of generators and/or fluid intercept valves.

By activating the changeover from bus, the system exposes a communication object which can be synchronized with the conduction mode of any bus device, e.g. a room thermostat acting as the changeover master. The actual conduction mode is stored inside the non-volatile memory: by cutting the KNX power supply, when power is restored the last stored conduction value is saved.

The changeover can be manually performed also through the display of the device: in this case, the EK-HH1-TP controller acts as the changeover master for all room thermostats sharing the same hydraulic supply.

6.6.5 Types of supported servomotors

The controller can handle servomotors with high impedance 0-10 V control signal and servomotors with 3 point floating, with 230 Vac/24 Vac power supply. For the latter, the opening time parameter must be set, which is the time spent by the servomotor to complete a full stroke, from closing to total aperture. This data is supplied by the servomotor's manufacturer together with the paired valve, or can be monitored by making the controller separately supply the servomotor. The opening time is a parameter that must be properly set in order to guarantee a precise delivery temperature regulation: the opening percentage coming out of the proportional-integral controller is transformed into an opening/closing time proportional to the total opening time. In other words, the position signal is transformed into a proportional time signal.

When powering up the device and every time a flow request ends, the valve is commanded to fully close: this sequence allow the position calibration, in other words, the position evaluated by the controller corresponds to the actual position. During the mixing group operation, the evaluated position may diverge from the valve actual position: eventually, the actual and evaluated position will converge anyway.

6.6.6 PI (proportional-integral) regulator

The delivery temperature of the mixing group is controlled in closed loop: the control variable is the valve position, while the process variable is the delivery temperature. In heating mode, by opening the valve, the water flow coming from the generator increases compared to the return water flow, which is colder because of the heat transferred to the building's structure: this causes an increase of the delivery temperature. Viceversa, in cooling mode, the refrigerated water flow coming from the generator increases compared to the return water flow, which is hotter because of the heat acquired from the building's structure: this causes a decrease of the delivery temperature. It is up to the controller to keep a fixed delivery temperature setpoint; the setpoint can be set either manually or automatically and this procedure is described in the next chapter, which is about control modes.

The default values of the parameters in ETS program are selected in order to guarantee a static precision of the control, not dynamic performance: in other words, it is important, for example, that a 35°C temperature is kept constant for several hours in order to guarantee a proper heating of the structures. Default values are the following:

- PB (proportional band): 15 K
- Ti (integral time): 600 s

With a proportional band of $PB = 15\text{ K}$, for example, if temperature setpoint = 35°C and actual delivery temperature = 27.5°C, the calculated valve position will be = 50%; if temperature setpoint = 35°C and actual delivery temperature = 20°C, the calculated valve position will be = 100%. With an integral time $Ti = 600\text{ s}$, if temperature setpoint = 35°C, actual delivery temperature = 27.5°C and valve position = 50%, the valve position will be repeated after 60s, in other words after 10 minutes the valve position will be = 100%.

Another parameter is the *Dead band*, with default value = 0,2 °C. It is an error interval within which the integral action is "frozen" and is not an active part of the regulation, in order to reduce the stress on the mixing valve's servomotor. A dead band = 0 K means that the integral action is always active until the delivery setpoint is reached.

6.6.7 Circulator protection function

After long inactivity periods, it is possible that the centrifugal circulator installed on the mixing group gets stuck due to impurities and/or calcium deposit: to prevent this from happening, the EK-HH1-TP controller can periodically activate the circulator for a short time in order to eliminate that deposit.

The device is equipped with a counter which is started at the end of each activation. When the time interval set in the *Frequency* parameter is reached, the circulator is started to prevent it from getting stuck. The ON time depends on the value set in the *Time interval* parameter.

6.6.8 Anticondensation protection function

In cooling mode, the EK-HH1-TP controller can realize several strategies for anticondensation prevention and detection on radiant surfaces. These strategies can be active or passive. The former case in about taking preventive actions on the delivery temperature in order to prevent the surface temperature from becoming too close to the dew point: these strategies require a continuous monitoring of temperature and relative humidity

via KNX sensors; for further information, please refer to the chapter regarding control ways in cooling mode through internal thermoigrometric conditions.

In simple applications, a passive protection can be performed, using anticondensation contact probes. Those probes are ON/OFF and can be connected to inputs IN4 and IN5 (up to 2 anticondensation probes, connected to the 2 inputs) if these inputs are not yet configured for heating/cooling changeover and/or activation.

When a condensation presence is detected, the controller can respond in any of the following ways:

- Circulator lock
- Mixing valve in by-pass position and circulator ON

In the former case, the circulation is immediately stopped so no further energy is supplied to the radiant surfaces; in the latter case, the heating fluid is recirculated in order to quickly exchange cooling energy and raise the temperature of the radiant surfaces.

The probe must be installed in a proper position: in case of radiant floor, its support bracket must stay in contact with the delivery pipes, while its body must stay in contact with air; in case of radiant ceiling, the probe must be installed into the counterceiling, in contact with the cupels on the water pipe delivery.

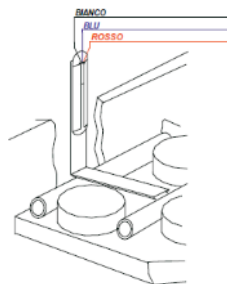

In radiant floor systems, it is recommended not to install the anticondensation probes in contact with collectors closed inside junction boxes. This action can be too precautionary and can cause the EK-HH1-TP not to work properly.

6.6.9 Alarms

The alarms handled by the EK-HH1-TP controller are grouped into the following categories:

- Analog input alarms
- Bus input alarms
- Operating alarms

Alarms about temperature analog inputs are about failures and are detected if the connected sensors are not wired to their terminals or have uncorrect temperature ranges (e.g. the sensors are not NTC, 30 k Ω at 25°C). If the temperature sensors are monitoring only (e.g. if they are connected to IN4 and IN5 inputs), the alarm does not stop the mixing group regulation. However, the delivery sensor on IN1 – always –, the return sensor on IN2 and the outside temperature sensor on IN3, if used in the configurated control mode (e.g. return temperature compensation or climatic compensation), can interlock the regulation on the mixing group.

Alarms on bus inputs are divided into 2 types: failure alarms in case the controller receives uncorrect values through communication objects, and timeout alarms in case when powering up or reading values cyclically, the reading requests on bus are not answered. The External temperature from bus timeout belongs to the

latter category: if external climatic compensation mode has been configured, this alarms interlocks the regulation on the mixing group.

If the control mode foresees a synchronization of environment sensors from bus, the timeout alarm on a specific communication object of a single zone does not stop the regulation on the mixing group. The regulation stops if all communication objects time out. For further information please refer to the chapter about *Control modes*, paragraph *Connecting communication objects of KNX sensors*.

The following operating alarms are handled:

- Heating mode: delivery overtemperature alarm
- Cooling mode: delivery undertemperature alarm
- Cooling mode: ancondensation alarm

Anticondensation alarm has already been explained in the previous paragraph. Both temperature alarms can cause damage to people or things. A delivery overtemperature alarm in heating mode can damage the screed or the coating in case of extended overtemperature. A delivery undertemperature alarm in cooling mode can cause condensation on the radiant surfaces. In both cases, the controller executes a sequence in order to distinguish transitional phenomena from those caused by faults and/or failures. The sequence is composed by the following steps:

- 1) Delivery temperature measurement and comparison with the set alarm thresholds
- 2) In case of an alarm detection, the circulator keeps working, the mixing valve is brought to by-pass position in order to dispose the heating/cooling energy on the plant
- 3) If the alarm condition returns to normal within 4 minutes, the controller returns to its normal operation and modulates again
- 4) If after 4 minutes from alarm detection, the overtemperature/undertemperature alarm condition is still active, the circulator is stopped.

Restoring is performed automatically as soon as the delivery temperature sensor returns within its thresholds with set hysteresis values. If a delivery temperature alarm is detecting at power-up (e.g. caused by conductive phenomena and/or leakages on the mixing valve), even after a KNX bus voltage failure, the circulator is activated at point 2 of the sequence. Operating alarms cause the interlock of the regulation.



The EK-HH1-TP controller is fitted with a delivery overtemperature alarm using the same immersion sensor as the regulation. In radiant floor heating applications, in combination with high temperature heat generators, installing an external safety thermostat in series with the circulator command is highly advised, in order to properly protect both the screed and the coating.

Communication objects indicating alarm conditions to a supervisor or other bus devices are available. The *Temperature control alarm* communication object indicates an alarm presence on the bus, in the following conditions:

- For an external event which can be configured and linked to the *Heat generator lock* communication object
- For a failure of the temperature sensor connected to one of the KNX bus inputs (low measured ambient temperature when NTC sensor resistance value is high or high measured ambient temperature when NTC sensor resistance value is low)
- For a timeout (no update of the data from bus) of the analog sensors from bus

The alarm LED on the front side of the device indicates, when active, the presence of any operating anomaly. Please refer to the Alarms menu on the alphanumeric display in order to analyze a list of all active alarms.

6.7 Physical inputs

The controller is equipped with 5 configurable inputs in order to fulfill all possible control and monitoring needs for states and temperatures of a thermal plant. Inputs IN1, IN2 and IN3 are temperature analog inputs, while inputs IN4 and IN5 are freely configurable as temperature or binary inputs. These are the possible connection choices for the 5 inputs:

- IN1: delivery temperature sensor
- IN2: return temperature sensor or generic temperature sensor
- IN3: outdoor temperature sensor or generic temperature sensor
- IN4: contact for activation request or generic temperature sensor or anticondensation sensor or generic contact
- IN5: contact for heating/cooling changeover or generic temperature sensor or anticondensation sensor or generic contact

Each input can be linked to a communication object for sending information on the bus on event of change or range and/or cyclical variation. Each input configured for temperature reading can also be linked to 2 comparators with sending of their state on the bus.

6.8 Physical outputs

The controller is equipped with the following outputs:

- DO1, DO2, DO3: monostable relay outputs, voltage-free contact
- TR1/TR2: triac outputs with external power supply
- AO1: 0-10 V analog output

The DO1 output is non configurable and is dedicated to turn on/off the circulator of the mixing group. DO2 and DO3 outputs can be configured as outputs calculated by logic function with or without activation delay, or they can be controlled through communication objects exposed in the application program. For example, these versatile outputs can act as: command of a high temperature (fan-coil) circulator through a logic OR of its flow requests, command of a dehumidifier, command of a zone valve. Alternatively, they can be used for purposes other than temperature control.

TR1/TR2 outputs, when a 3 floating point servomotor is used, can expose communication objects indicating its state; if these outputs are not used to control the servomotor, they can be directly controlled through communication objects exposed in the application program. Same considerations apply for the 0-10 V analog output.

6.9 Control modes

In the previous chapter we analyzed how the delivery temperature on the mixing group is controlled; in this chapter, we will take into account all the different ways to manually or automatically select the delivery temperature setpoint. The EK-HH1-TP controller offers a wide range of solutions, suitable for all needs in radiant control systems, both for heating and cooling.

The most proper solution has to be chosen very carefully, taking into account both the adopted thermohydraulic configuration and the availability of KNX sensors installed in the building for monitoring of the environment's internal conditions.

Each control mode foresees a series of parameters, some of which, besides being configured through ETS application program, can be edited or tuned up even at a later time, through the display menus or a supervision system, via the exposed communication objects.

6.9.1 Heating: fixed point

Fixed point mode foresees a single delivery temperature setpoint and is suitable for controlling a mixing group in a building with very low outwards heat loss, i.e. not dependent from external conditions. This mode is also suitable for commercial buildings, where minimum room temperatures must be kept. This control mode is characterized by an extremely simple configuration and only requires the connection of a delivery temperature sensor to IN1 input. Activation can be made through a binary input connected to IN4, a logic OR of the flow requests coming from the room temperature controllers integrated in the KNX bus devices (by connecting the exposed communication objects for max. 16 zones), and a combination of the above mentioned methods.

This mode offers the benefits of using a mixing group and allows a limited flow withdrawal from the generator's direct way based on heat exchange between radiant surfaces and environment: during the early hours of heating, the setpoint is maintained with a significant mixing valve aperture in order to compensate the high temperature delta between delivery and return; once the environment approaches the comfort temperature conditions, this delta decreases and the flow withdrawal from the direct way decreases as well, with subsequent benefits on primary energy consumptions.

6.9.2 Heating: climatic compensation

The climatic compensation mode is characterized by the classic 3-point climatic curve: the delivery setpoint changes based on outdoor conditions. The environment loses heat outwards at increasing speed during the outside temperature excursion towards minimum values. This power loss has to be compensated by a delivered heat power in order to reach the desired room temperature. The delivered heat power is then modulated by increasing the delivery temperature.

This control mode requires the connection of the delivery temperature sensor to input IN1 and the outside temperature sensor to input IN3. Alternatively, the outside temperature sensor can be acquired from bus through a communication object. This configuration is useful when it is necessary to control more than one mixing group: a EK-HH1-TP device acquires the outside temperature through an analog input and sends its value on the bus to other control devices. Activation can be made through a binary input connected to IN4, a logic OR of the flow requests coming from the room temperature controllers integrated in the KNX bus devices (by connecting the exposed communication objects for max. 16 zones), and a combination of the above mentioned methods.

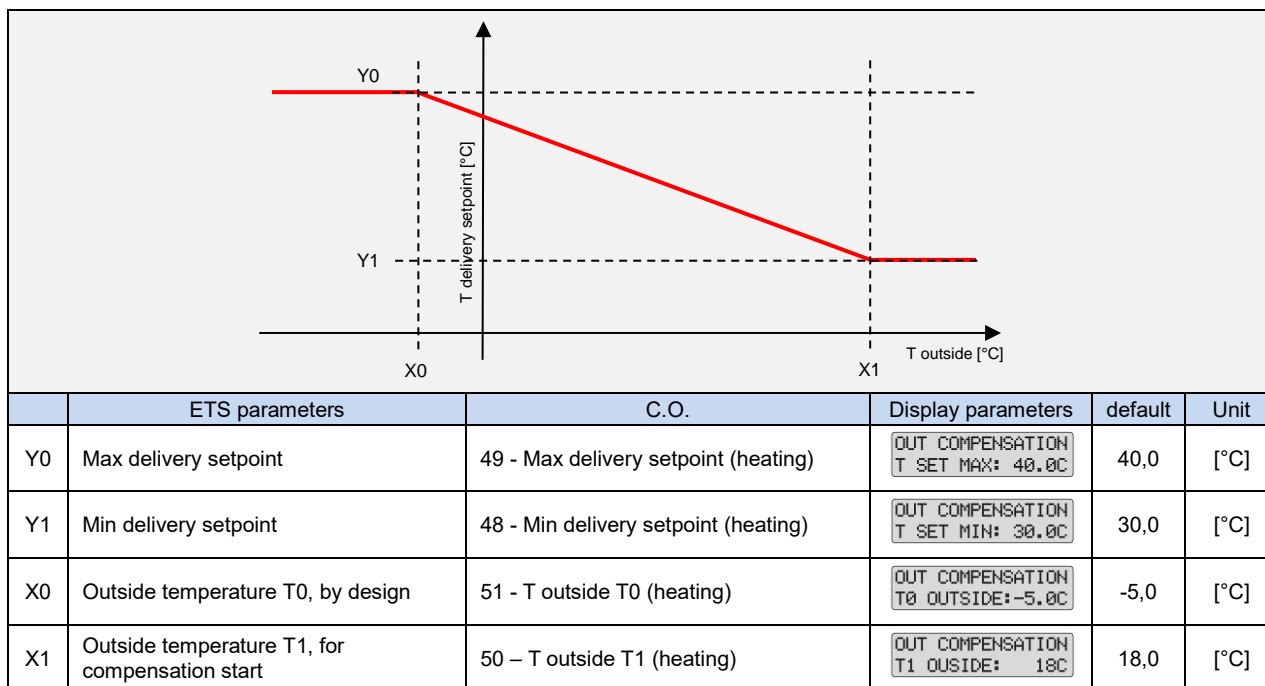

The outside temperature by design T0 corresponds to the minimum outside temperature used in the design to size the generator. The more the building is thermally isolated, the less steep the curve will be.

6.9.3 Heating: recalibration based on return temperature

This control mode uses the information of the return temperature signal measured on the mixing group: the return temperature supplies information about heat exchange between radiant surfaces and heated environment. Project ΔT is fixed by the thermohydraulic plant design: the circulator flow forces the fluid to have a prefixed temperature exchange. If actual ΔT is less than project ΔT , this means that heat exchange of radiant surfaces with environment is too low: the setpoint is then increased according to a preset curve. On the contrary, if actual ΔT is more than project ΔT , this means that heat exchange of radiant surfaces with environment is too high: the setpoint is then decreased according to a preset curve.

This control mode requires the connection of the delivery temperature sensor to input IN1 and the return temperature sensor to input IN2. Activation can be made through a binary input connected to IN4, a logic OR of the flow requests coming from the room temperature controllers integrated in the KNX bus devices (by connecting the exposed communication objects for max. 16 zones), and a combination of the above mentioned methods.

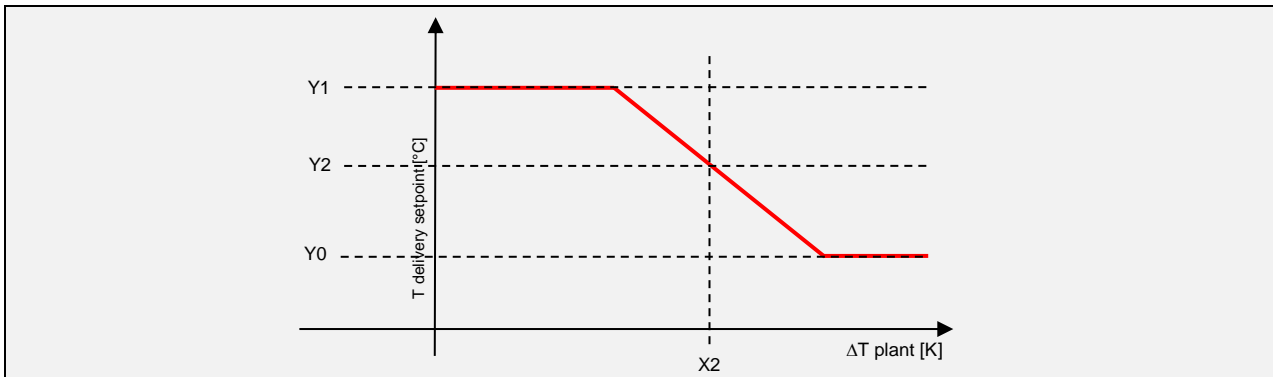

	ETS parameters	C.O.	Display parameters	default	Unit
Y2	Project delivery setpoint	47 - Project delivery setpoint (heating)	TR COMPENSATION T SET: 35.0C	35,0	[°C]
X2	Project ΔT	52 - Project ΔT	TR COMPENSATION DELTA T: 6.0C	6,0	[K]
Y0	Min delivery setpoint	48 - Min delivery setpoint (heating)	TR COMPENSATION T SET MIN: 30.0C	30,0	[°C]
Y1	Max delivery setpoint	49 - Max delivery setpoint (heating)	TR COMPENSATION T SET MAX: 40.0C	40,0	[°C]

6.9.4 Heating: recalibration based on internal conditions

This control mode consists in modulating the delivery temperature setpoint on the mixing group taking into account the requirements of the heated environments, therefore in function of the environment desired temperature and in function of how much the actual temperature is lower than the desired one. The lower the environment temperature, the higher the required delivery temperature setpoint; the more the desired conditions approach, the lower the delivery temperature setpoint. In other words, the heat power is modulated towards the upper side of the radiant surface. This control mode requires a data exchange between the unit controlling the mixing group and the room thermostat and is suitable for a solution based on KNX bus.

The adopted scheme is a cascade control with an external (ambient temperature SET control) and an internal loop (control of the delivery temperature on the mixing group).

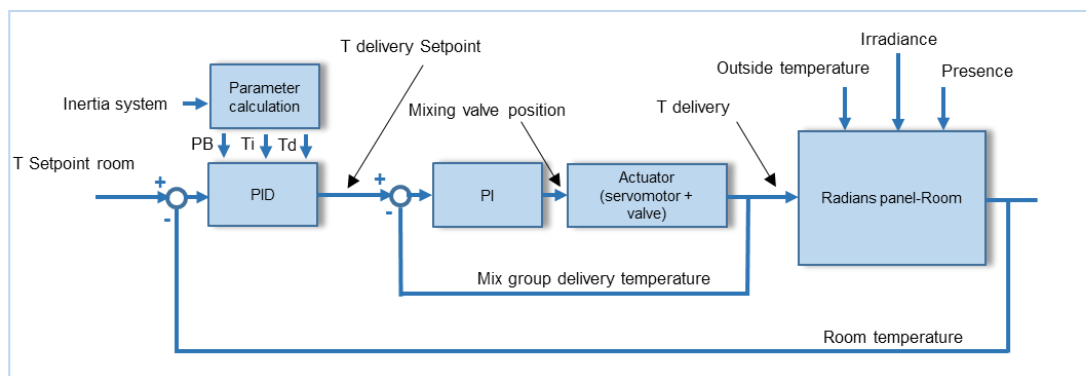

There are 2 measured variables: the delivery temperature, detected by an immersion sensor installed on the mixing group, and the ambient temperature. The only editable variable in this system is the position of the mixing valve, which is calculated by the controller itself.

In the above block diagram, the measured and desired ambient temperature refer to only one zone and thermostat. In case of multiple zones and thermostats, the maximum deviation between T Setpoint and T Measured must be evaluated in order to identify the most disadvantaged environment. The control unit

modulates the delivery temperature in order to fulfill the control requirements of the actual most disadvantaged environment.

For this specific application, controllers with a superior hysteresis have been implemented in ekinex products: the products are room thermostats EK-EP2-TP, EK-EQ2-TP and the actuator/controller for distribution manifolds EK-HE1-TP. This hysteresis type is also implemented in pushbutton series EK-ED2-TP and EK-E12-TP.

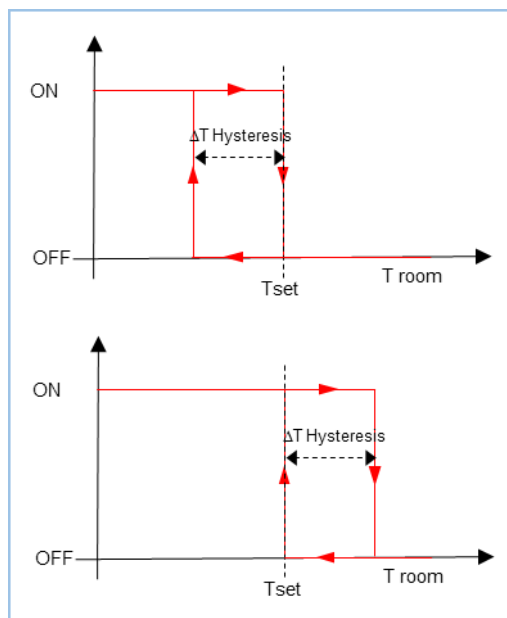

Those products, in a heating radiant application, can be configured with a controller equipped with a 2-point superior or inferior hysteresis. The latter choice is suitable for this type of control in residential installations where different requisites are homogeneous.

The parameter *System inertia* is introduced to easily calibrate the controller based on a dynamic mode oriented to a heated screed-environment system: it can vary between 100% (7-8 cm of sand and concrete screed) and 15% (dry screed).

The parameter *Setpoint change range* (default: 8°C) is to be intended as a symmetric range around the *Project delivery setpoint*, namely the calculated setpoint can vary between *Project delivery setpoint - Setpoint change range* and *Project delivery setpoint + Setpoint change range*.

The EK-HH1-TP controller requires the connection of the delivery temperature sensor to input IN1 and activation can be made through a binary input connected and a logic OR of the flow requests coming from the room temperature controllers integrated in the KNX bus devices (by connecting the exposed communication objects for max. 16 zones).

6.9.5 Heating: climatic compensation and recalibration based on internal conditions

This control mode takes into account both outside and internal environmental conditions and can only be applied by an activation from bus through a logic OR of the flow requests coming from the room temperature controllers integrated in the KNX bus devices (by connecting the exposed communication objects for max. 16 zones), with activation from bus and binary input. The EK-HH1-TP controller requires the connection of the delivery temperature sensor to input IN1 and the outside temperature sensor to input IN3.

6.9.6 Heating: connecting communication objects of KNX sensors

In this section, we will show the block diagrams of the communication objects which must be linked in order to synchronize the EK-HH1-TP controller to KNX distributed sensors. The device can synchronize its communication objects in 2 modes:

- Through a cyclic sending of group addresses from the sensors to the controller
- Through reading requests of group addresses by the controller, at startup and cyclically

Cyclic sending from the sensors to the controller has a timeout parameter (default: 5 min) outside of which the regulation is stopped and an alarm linked to the corresponding sensor is activated. Reading at startup is useful to guarantee the device synchronization after bus voltage is restored. If at least one KNX sensor does not answer to the requests, the regulation is not stopped until all sensors configured in that zone are missing. Both synchronization modes can be combined.

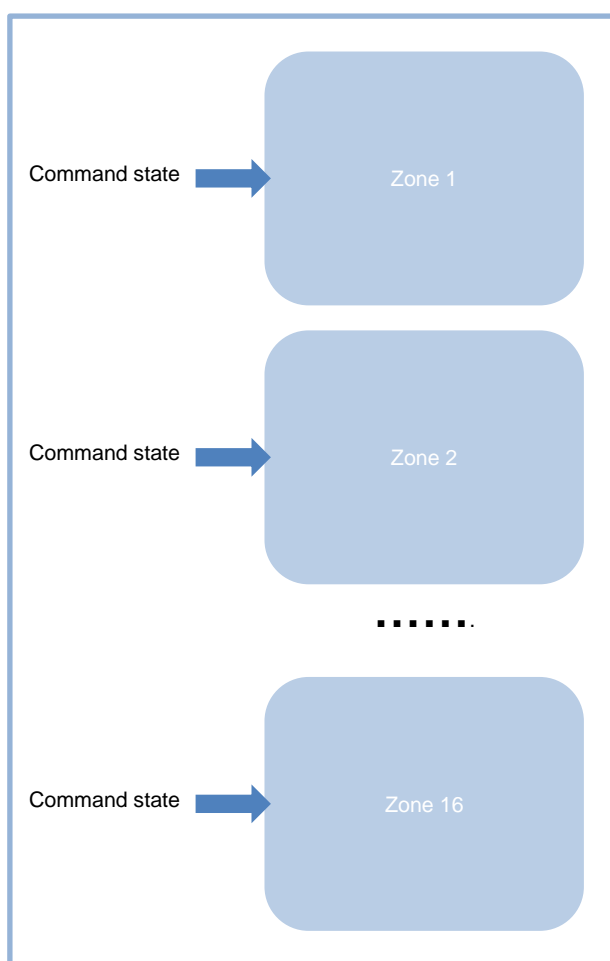

This block diagram applies with activation from bus, or from bus and binary input, in the following cases:

- fixed point
- climatic compensation
- recalibration based on return temperature

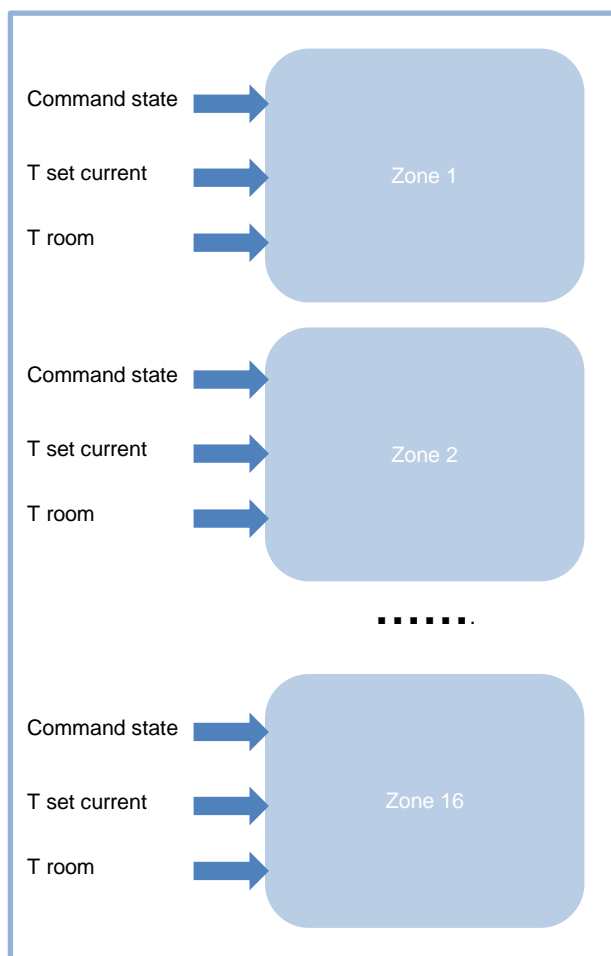

This block diagram applies in the following cases:

- recalibration based on internal conditions
- climatic compensation and recalibration based on internal conditions

6.9.7 Cooling: fixed point

Like fixed point in heating mode, this control mode is characterized by an extremely simple configuration and only requires the connection of a delivery temperature sensor to IN1 input. Setpoints for cooling and heating are separated. Activation can be made through a binary input connected to IN4, a logic OR of the flow requests coming from the room temperature controllers integrated in the KNX bus devices (by connecting the exposed communication objects for max. 16 zones), and a combination of the above mentioned methods.

It is recommended to pair this control mode to a passive anticondensation protection by using contact probes connected to binary input IN5, or to IN4 and IN5 for standalone applications.

6.9.8 Cooling: climatic compensation

This control mode is widespread in cooling control of radiant systems. Its operating principle foresees a delivery temperature increase when outside conditions become more onerous for minimizing discomfort between indoor and outdoor environments. This logic opposes to the one adopted in heating climatic compensation: it is also to consider that more thermal capacity of the envelope equals to more time needed by the thermal wave to be transmitted outwards; moreover, the more the thermal isolation of the envelope, the more the attenuation of the thermal wave, i.e. the less the power needed to dissipate the transmitted heat.

This control mode requires the connection of the delivery temperature sensor to input IN1 and the outside temperature sensor to input IN3. Alternatively, the outside temperature sensor can be acquired from bus through a communication object. This configuration is useful when it is necessary to control more than one mixing group: a EK-HH1-TP device acquires the outside temperature through an analog input and sends its value on the bus to other control devices. Activation can be made through a binary input connected to IN4, a logic OR of the flow requests coming from the room temperature controllers integrated in the KNX bus devices (by connecting the exposed communication objects for max. 16 zones), and a combination of the above mentioned methods.

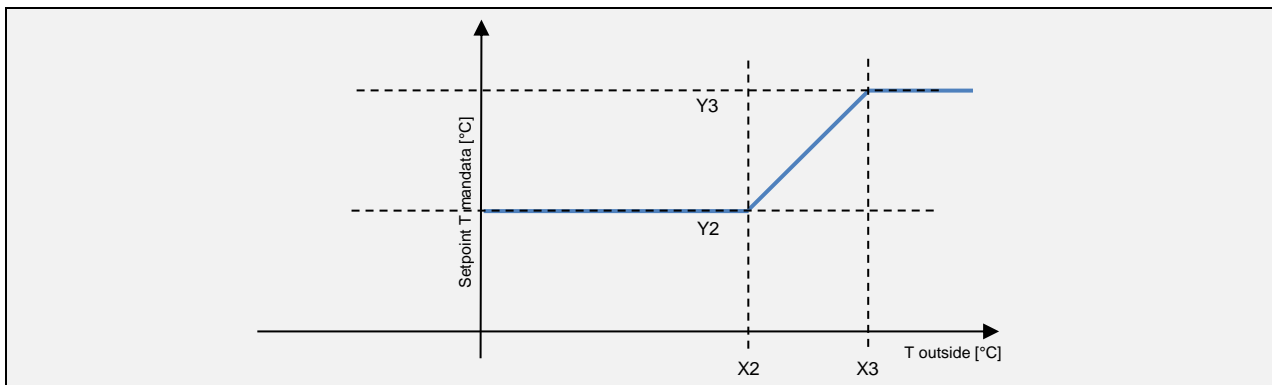

	ETS parameters	C.O.	Display parameters	default	Unit
Y2	Min delivery setpoint	55 - Min delivery setpoint (cooling)	OUT COMPENSATION T SET MIN: 16.0C	16,0	[°C]
Y3	Max delivery setpoint	56 - Max delivery setpoint (cooling)	OUT COMPENSATION T SET MAX: 20.0C	20,0	[°C]
X2	Outside temperature T2, for compensation start	57 - T outside T2 (cooling)	OUT COMPENSATION T2 OUT: 25.0C	25,0	[°C]
X3	Project outside temperature T3	58 - T outside T3 (cooling)	OUT COMPENSATION T3 OUT: 35.0C	35,0	[°C]

It is recommended to pair this control mode to a passive anticondensation protection by using contact probes connected to binary input IN5, or to IN4 and IN5 for standalone applications.

6.9.9 Cooling: recalibration based on internal thermohygrometric conditions

This control mode finds its goal in maximizing the performance of the radiant surface keeping the deliver temperature as low as possible, while actively avoiding condensation: this condition is achieved by monitoring both temperature and relative humidity by means of KNX sensors distributed in the environment. It is a control mode which benefits from the exchange of information on the bus between the controller acting on the mixing group and the sensors.

While in radiant floor heating, the temperature difference between heating fluid and environment changes within a 10-25°C range, in cooling mode the thermal gradients are more limited, in a 6-12°C range: for this reason the delivery temperature needs to be kept as low as possible in order to achieve the best performance.

The EK-HH1-TP controller can directly receive the dew point temperature value, a fundamental value in order to realize an active protection against condensation of the radiant surfaces, from KNX sensors or can be internally calculated for a maximum of 16 zones.



The dew point temperature is the temperature to which an air mass must be cooled down in order to start condensating, at constant pressure. A dry air mass, i.e. with a low relative humidity, must be cooled down a lot before it starts condensating, i.e. its dew point temperature is low. On the contrary, a moist air mass will not need to be cooled down a lot before it starts condensating, so its dew point temperature will be higher.

Some numeric data: in a bright summer day with T_{Amb}=25°C and RH=55%, T_{dewpoint}=15,4°C; in a moist day with T_{Amb}=24°C and RH=68%, T_{dewpoint}=17,7°C.

Cooling control is based on the fact that if in the latter case the surface temperature of a floor is 16°C (water delivery temperature at 16°C), the surface condensation will be inevitable, since the air will already start condensating at 17,7°C.

The delivery setpoint is calculated in the following way:

$$T \text{ Setpoint} = \text{MAX} (T \text{ Project delivery setpoint}, T_{\text{dewpointMAX}} + \text{Safety factor})$$

This equation calculates a minimum delivery setpoint value which will be adopted every time the dew point temperature is very low. As soon as the indoor latent heat increases, the equation ensures that the deliver setpoint will increase, therefore also the radiant surface temperature will be higher than its dew point condition.

The safety factor can be negative or positive, depending on the installation type: in a radiant floor plant it is usually positive, while in a plasterboard counterceiling it can as well be negative.

The EK-HH1-TP controller requires the connection of the delivery temperature sensor to input IN1 and activation can be made through a binary input connected and a logic OR of the flow requests coming from the room temperature controllers integrated in the KNX bus devices (by connecting the exposed communication objects for max. 16 zones), both with activation from bus and from binary input.

6.9.10 Cooling: clim. Comp. and recalibration based on internal thermohygrometric conditions

This control mode takes into account both outside and internal conditions in terms of temperature and relative humidity and can only be applied by an activation from bus through a logic OR of the flow requests coming from the room temperature controllers integrated in the KNX bus devices (by connecting the exposed communication objects for max. 16 zones), with activation from bus and binary input. The EK-HH1-TP controller requires the connection of the delivery temperature sensor to input IN1 and the outside temperature sensor to input IN3.

6.9.11 Cooling: connecting communication objects of KNX sensors

In this section, just like the heating case, we will show the block diagrams of the communication objects which must be linked in order to synchronize the EK-HH1-TP controller to KNX distributed sensors. Please refer to the paragraph *Heating: connecting communication objects of KNX sensors* for synchronization modes.

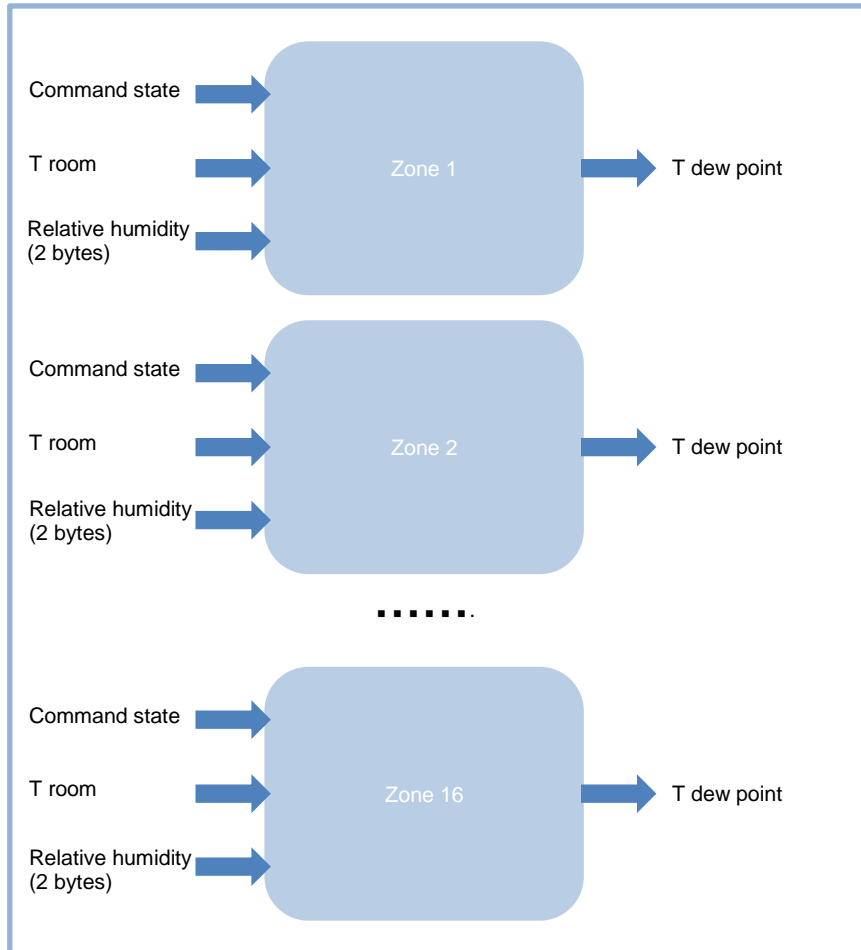

This block diagram applies if the 2-bytes [DPT 9.007] internal dewpoint processing with relative humidity acquisition is activated, in the following control modes:

- recalibration based on internal thermohygrometric conditions
- climatic compensation and recalibration based on internal thermohygrometric conditions

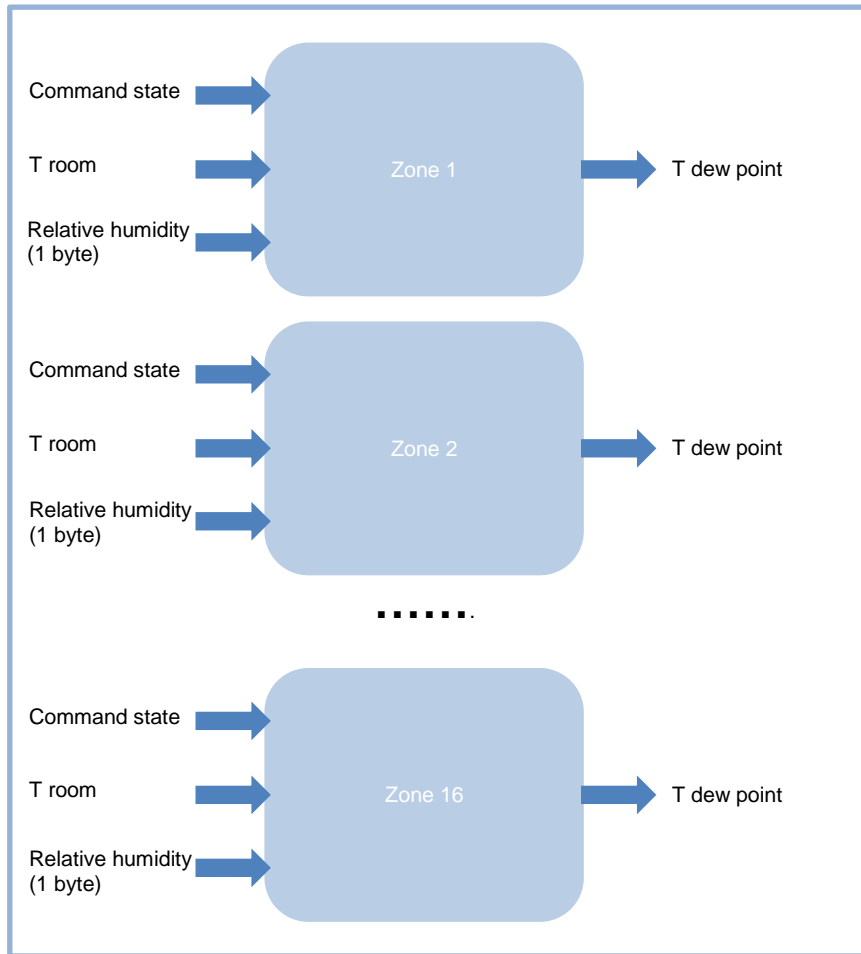

This block diagram applies if the 1-byte [DPT 5.001] internal dewpoint processing with relative humidity acquisition is activated, in the following control modes:

- recalibration based on internal thermohygrometric conditions
- climatic compensation and recalibration based on internal thermohygrometric conditions

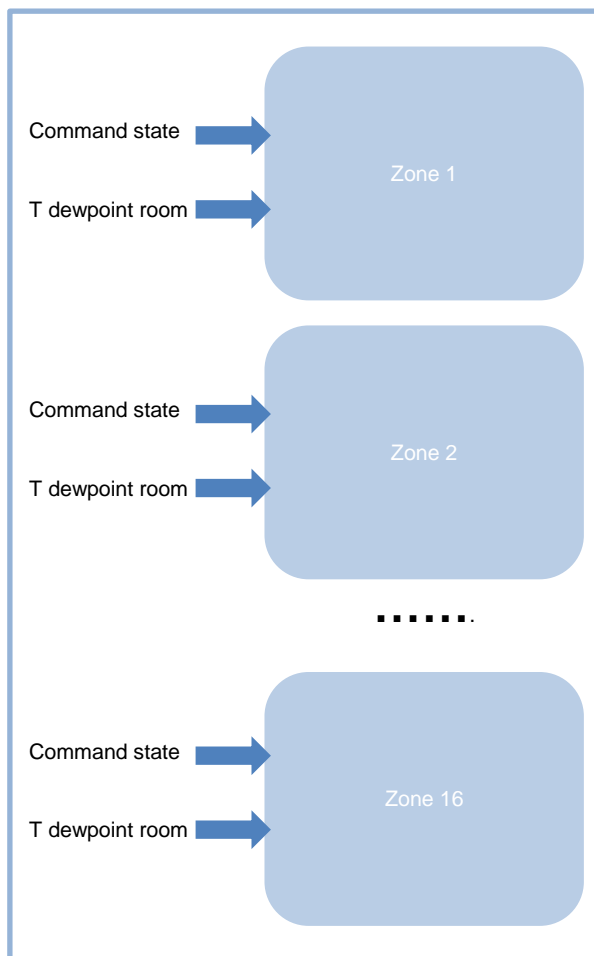

This block diagram applies if no internal dewpoint processing with relative humidity acquisition is activated (usage in combination with EK-EQ2-TP room thermostat with internal value processing), in the following control modes:

- recalibration based on internal thermohygrometric conditions
- climatic compensation and recalibration based on internal thermohygrometric conditions

7 Display

7.1 Navigation buttons

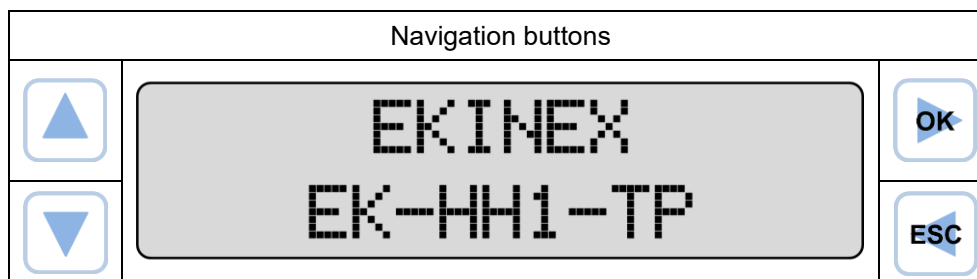

	UP	This button scrolls the menu upwards, increments the numeric values and selects the different options of a parameter.
	DOWN	This button scrolls the menu downwards, decrements the numeric values and selects the different options of a parameter.
	CONFIRM	This button switches to a submenu and confirms the modification of a parameter Il pulsante effettua il passaggio ad un sottomenù e conferma la modifica di un parametro
	RETURN	This button returns from a submenu to the previous menu and cancels the modification of a parameter

7.2 Navigation menus

EKINEX EK-HH1-TP					
MONITORING MENU	CONDUCTION MODE: HEATING	T DELIVERY 36.8C T SETPOINT 37.0C	MIX VALVE 45.5% CIRCULATOR ON	STATUS: RUNNING	T OUTSIDE -11,5C
	T RETURN 31,2C	IN1: 54.5C IN2: 37.2C	IN1: ON IN2: ON	TRIAC OPEN: ON TRIAC CLOSE: OFF	D02: ON D03: ON
CHANGE MODE MENU	CHANGE MODE: COOLING	ARE YOU SURE OF CHOICE? YES			
SETTINGS MENU	MIX GROUP MENU	FULLSTROKE TIME: 145S	PROPORTIONAL BAND: 15K	INTEGRAL TIME: 120S	VALVE PROTECTION SPAN: 10S
		HEATING ALARM T HIGH: 45C	HEATING ALARM T LOW: 18C	COOLING ALARM T HIGH: 22C	COOLING ALARM T LOW: 10C
	HEATING MENU	FIXED POINT T SET: 35C			
		OUT COMPENSATION T1 OUTSIDE: 18C	OUT COMPENSATION T0 OUTSIDE: -5.0C	OUT COMPENSATION T SET MIN: 30.0C	OUT COMPENSATION T SET MAX: 40.0C

		INT COMPENSATION T SET: 35.0C	INT COMPENSATION INERTIA: 60.0%	INT COMPENSATION RANGE: 8.0C	
		TR COMPENSATION T SET: 35.0C	TR COMPENSATION DELTA T: 6.0C	TR COMPENSATION T SET MIN: 30.0C	TR COMPENSATION T SET MAX: 40.0C
	COOLING MENU	FIXED POINT T SET: 16.0C			
		OUT COMPENSATION T2 OUT: 25.0C	OUT COMPENSATION T3 OUT: 35.0C	OUT COMPENSATION T SET MIN: 16.0C	OUT COMPENSATION T SET MAX: 20.0C
		INT COMPENSATION T SET MIN: 16.0C	INT COMPENSATION SEC. F.: 1.5C		
ALARMS MENU		A01 A04	A07 A11	(last 10 alarms list)	
MANUAL COMMANDS MENU	ENABLE OUTPUT MANUAL MODE: YES	TRIAC: OPEN	0...10V OUTPUT: 20%	D01: ON	D02: ON
	D03: ON				
INFO MENU	EKINEX EK-HH1-TP FIRMWARE: V1.0.2	KNX PHY ADDRESS: 10.7.251			

INSERT PASSWORD: XXXX	<p>In order to access to Settings menu, submenus Change Mode, Mixing, Heating and Cooling, to Manual Commands menu and Screed Start menu, it is possible to insert the "Insert 4-digit password" first. The password can be configured in ETS: if the inserted password is wrong, it will not be possible to access to those screens and a "Wrong password" screen appears. The password is made by 4 numeric digits. If the password protection is unlocked, after 4 minutes since the last interaction with the display, the password protection is automatically activated again.</p>
NOT CORRECT PASSWORD.	

8 Application program for ETS

In the following chapters there is the list of folder, parameters and communication objects of the application program.

i Values in **bold** are the *default* ones.

Device parameters are divided into main and specific parameters, grouped in folders. Following is the tree structure of the application program with its main folders.

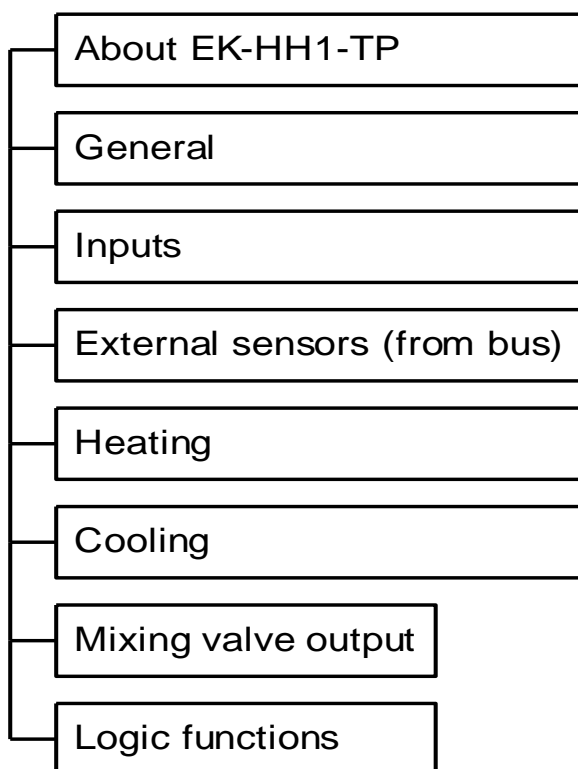

8.1 About EK-HH1-TP

The folder **Info su EK-HH1-TP** is for information purposes only and does not contain parameters to be set. The information given is:

© Copyright SBS S.p.A. 2016
 Application software for ETS4
 Version 2.00 (or later)
 KNX room temperature controller with LC-display and humidity sensor
 SBS S.p.A.
 Via Circonvallazione s/n
 I-28010 Miasino (NO) Italy

8.2 General parameters

In the *General Parameters* folder, coherently with all ekinex® devices for temperature control, the user has to make some initial choices about the plant.

This folder contains the following parameters:

- Function: heating, cooling and both heating and cooling
- Mode switching types: from bus, manually from binary input or manually from display
- Activation type (start/stop sequence of the mixing group): from binary input, from KNX bus sensors or both
- Output activation delay
- Display language
- Manual operation on binary and analog outputs enable
- Supply voltage alarm enable
- Logic functions enable
- Delay after bus voltage recovery

The choices made in the *General Parameters* folder will affect all parameters and communication objects exposed in the following tabs. If selected conduction mode is heating and cooling and if switching is made by input contact, automatically in the *Inputs* folder the proper freely programmable input will be set accordingly (Input 5, binary). Similarly, if activation of the mixing group is carried out by bus communication objects, in the *Input from bus* folder the *Zone* parameter will be enabled: a zone number between 1 and 16 can be selected, as well as product activation status reading and cyclic reading. This allows the device to synchronize all bus information needed to automatically implement its control algorithms when power is supplied.

Communication objects which are exposed for each zone also depend on the peculiar control type chosen in the *Heating and/or Cooling* folder: e.g., if fixed point is selected, only the objects needed to determine the flow request in order to perform a logical OR of all requests will be exposed; otherwise, if compensation on internal condition is selected, desired operating ambient temperature and measured ambient temperature will be exposed, too. Once a number of zone and a control type have been selected, a number of C.O. will be exposed for each zone: it is still possible to put more C.O. in parallel using a single group address in order to realize more flexible configurations. For example, it is possible to take the consensus from only one zone and evaluate the external conditions of 2 zones: in the *External sensors* folder, 2 zone are selected and the C.O. about flow request are linked to the same group address.

On the other hand, the configuration of parameters inside the *Inputs* and *Inputs from bus* folders affect the options available in the *Heating and/or Cooling* folder: e.g., if no external temperature sensor is configured, a warning in the *Heating and/or Cooling* folder will be displayed when trying to configurate the control type as *Climatic compensation*. It is also possible to create a configuration for a thermal plant where a control unit acquires an external probe, sends it on the bus while another control unit performs a climatic compensation using the external probe acquired from bus: using passive probes, indeed, it would not be possible to connect them in parallel to multiple control units' inputs.

Parameter name	Conditions	Values
Function		heating cooling heating and cooling
Mode switching	Function = heating and cooling	from bus from binary input from display

Parameter name	Conditions	Values
Activation		from binary input from bus from binary input and from bus
	<p><i>With activation from binary input, the control unit works as standalone: the circulator starts and the valve begins to modulate until a contact on the binary input is closed. A simple clock scheduler can be connected to that input.</i></p> <p><i>With activation from bus, a logical OR among all flow requests from the temperature controllers on the bus is performed (up to 16 zones): if at least one thermostat requests a flow, the mixing group starts.</i></p> <p><i>With activation from binary input and from bus, the logical OR is performed both among the flow requests coming from all temperature controllers and using the state of the binary input.</i></p>	
Activation delay		180 s [other values in the range 0 ... 255 s]
	<p><i>This delay is useful when activation is performed taking into account the temperature controller commands to the distribution manifold actuator. After the command is issued, it is necessary to wait an amount of time before opening the electrothermal actuators, in order to prevent the circulator from pushing on closed circuits.</i></p>	
Binary input priority	Activation = from binary input and from bus	no / yes
	<p><i>If this option is enabled, the mixing group starts its delivery temperature modulation if there is at least a request from an ambient temperature controller and if the activation binary input is closed.</i></p>	
[...]		
Display language		english italian
Enable access password		no / yes
Access password	Enable access password = yes	9999 [other values in the range 0 ... 9999]
	<p><i>Password is made by 4 numeric digits. If the password protection is unlocked, after 4 minutes since the last interaction with the display, the password protection is automatically activated again.</i></p>	
[...]		
Manual operations		disabled enabled
Disable from bus	Manual operations = enabled	no / yes
Restore auto mode time (0 means no automatic restoring)	Manual operations = enabled	00:15:00 hh:mm:ss [range 00:00:00 ... 18:12:15]
Power loss alarm		disabled enabled

Parameter name	Conditions	Values
Delay after bus voltage recovery		00:00:05 hh:mm:ss [range 00:00:00 ... 18:12:15]
	<i>This parameter selects the delay from bus power-up to data transmission (status feedback, control output, etc.). This delay must be carefully selected in order to prevent, after a power supply fault and subsequent recovery, all devices from starting to communicate simultaneously, causing the available bandwidth to overload.</i>	
Logic functions		disabled enabled

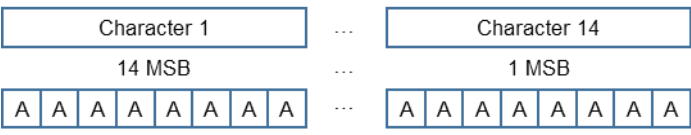
Object name	Conditions	Dim.	Flags	DPT	No. Comm. Obj.
Test mode activated	Manual operations = enabled	1 Bit	CR-T--	[1.003] enable	8
Disable front keyboard	Manual operations = enabled, Disable from bus = yes	1 Bit	C-W---	[1.002] boolean	9
Technical alarm		1 Bit	CR-T--	[1.005] alarm	0
	<i>This alarm activates if a sensor connected to an input is faulty (for analog sensors: open contact or short-circuit).</i>				
Communication alarm		1 Bit	CR-T--	[1.005] alarm	1
	<i>This alarm activates in case of a bus sensor timeout.</i>				
Thermal generator lock		1 Bit	C-W---	[1.005] alarm	2
	<i>This C.O. is used by an external device to shut down the controller operation. When alarm is detected, all mixing group outputs are deactivated.</i>				
Power off alarm	Communication alarm = enabled	1 Bit	CR-T--	[1.005] alarm	3
Temperature control alarm		1 Bit	CR-T--	[1.005] alarm	4
	<i>The internal temperature controller alarm is active in one of the following conditions:</i>				
	<ul style="list-style-type: none"> • Failure of one of the temperature sensors used for control • Timeout reception of a temperature sensor used for control • Alarm reception from C.O. Thermal generator lock 				
Alarm text		14 Bytes	CR-T--	[16.000] Character String (ASCII)	7
	 <p><i>This DPT is used to transmit the alarm as an ASCII string. The maximum length of the string is 14 characters (14 bytes). The string is sent starting from more significant character (14 MSB). If the string length is less than 14 characters, all unused bytes are filled with NULL character (00h). For example: "EKINEX is OK" is represented in the following way: 45h 4Bh 49h 4Eh 45h 58h 20h 69h 73h 20h 4Fh 4Bh 00h 00h</i></p>				
Heating/cooling changeover in	Function = heating and cooling, Mode switching = from bus	1 Bit	C-W---	[1.100] heating/cooling	10

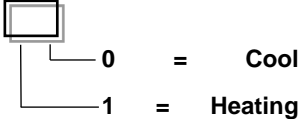
Object name	Conditions	Dim.	Flags	DPT	No. Comm. Obj.
Heating/cooling changeover out	Function = heating or cooling or heating and cooling	1 Bit	CR-T--	[1.100] heating/cooling	11
<p><i>The communication object is updated on the bus on event of change internally elaborated by the controller.</i></p> <p style="text-align: center;">[1.100] DPT Heat/Cool 1 Bit</p> <div style="text-align: center;">  </div>					
DO2 output control from bus	Logic function 1 ⇒ DO2 output control from bus = no	1 Bit	C-W---	[1.001] switch	42
DO3 output control from bus	Logic function 2 ⇒ DO3 output control from bus = no	1 Bit	C-W---	[1.001] switch	43
TR1 control from bus	Mixing valve output ⇒ Servomotor control = with 0-10V control signal	1 Bit	C-W---	[1.001] switch	44
TR2 control from bus	Mixing valve output ⇒ Servomotor control = with 0-10V control signal	1 Bit	C-W---	[1.001] switch	45
0-10V output control from bus	Mixing valve output ⇒ Servomotor control = 3 point floating	1 Byte	C-W---	[5.001] percentage (0..100%)	46

8.3 Inputs

The product is fitted with 3 fixed analog inputs:

- ⇒ Input 1: immersion delivery temperature sensor
- ⇒ Input 2: immersion return temperature sensor
- ⇒ Input 3: external temperature sensor

This simplifies the electrical installation: different plants have all the sensors connected to the same terminal blocks. Moreover, the sensor linearization can be optimized for each application inside its proper operating range: AI1 (range 0°C...100°C), AI2 (range 0°C...100°C) and AI3 (-40°C...50°C).

The 2 remaining inputs are freely configurable: they can be used to monitor the plant temperatures, since the device is usually installed inside a technical compartment; alternatively, they can be configured as binary inputs to detect states, or to connect more than one anticondensation probe or an external selector for heating/cooling switchover.

The *Inputs* folder is always active.

Parameter name	Conditions	Values
Input 1		[AI] delivery temperature sensor
	<i>Input 1 is always configured as analog and is reserved to the immersion delivery temperature sensor installed on the mixing group.</i>	
Input 2		disabled [AI] return temperature sensor [AI] generic (NTC) temperature sensor
	<i>Input 2 is always configured as analog and can be reserved to the immersion return temperature sensor installed on the mixing group. Enabling this input as return temperature sensor makes possible to activate, in the Heating folder, the control algorithm of setpoint recalibration, which evaluates the thermal exchange inside the environment based on delivery-return temperature delta. If input 2 is not used for this control type, it can be used to acquire a temperature to be monitored inside the technical compartment where the control unit is installed.</i>	
Input 3		disabled [AI] outside temperature sensor [AI] generic (NTC) temperature sensor
	<i>Input 3 is always configured as analog and can be reserved to the external temperature sensor which performs the climatic compensation during heating and/or cooling. If input 3 is not used for this control type, it can be used to acquire a temperature to be monitored inside the technical compartment where the control unit is installed.</i>	
Input 4	General Parameters ⇒ Activation = from binary input or from binary input and from bus	[DI] flow request contact
Input 4	General Parameters ⇒ Activation = from bus	disabled [AI] generic (NTC) temperature sensor [DI] generic contact [DI] anticondensation sensor contact
Input 5	General Parameters ⇒ Mode switching = from binary input	[DI] heating/cooling changeover contact
Input 5	General Parameters ⇒ Mode switching = from bus or from display	disabled [AI] generic (NTC) temperature sensor [DI] generic contact [DI] anticondensation sensor contact

Parameter name	Conditions	Values
Contact type	Input X = [DI] ...	NO (normally open) NC (normally closed)
	<i>Parameter always available when the input is configured as digital.</i>	
Debounce time	Input X = [DI] ...	00:00:00.200 hh:mm:ss.fff [range from 00:00:00.000 to 00:10:55.350]
	<i>Parameter always available when the input is configured as digital. The field has the format hh:mm:ss.fff (hours: minutes: seconds. milliseconds): the default value of 00:00:00.200 therefore corresponds to 200 milliseconds.</i>	
Filter type	Input X = [AI] ...	low medium high
	<i>Parameter always available when the input is configured as analog. Selectable values: Low = average value every 4 measurements Medium = average value every 16 measurements High = average value every 64 measurements</i>	
Correction of measured temperature	Input X = [AI] ...	0°C [range -5,0°C ... +5,0°C]
Min. change of value to send [K]	Input X = [AI] ...	0,5 [range from 0 to 5]
	<i>Parameter always available when the input is configured as analog. If set to 0, no value is sent to the change.</i>	
Cyclic sending interval	Input X = different from disabled	no sending [other values in the range 30 s ... 120 min]
Threshold 1	Input X = [AI] ...	not active / below / above
Value [°C]	Input X = [AI] ... Threshold 1 = below or above	7 [range from 0 to 50]
Threshold 2	Input X = [AI] ...	not active / below / above
Value [°C]	Input X = [AI] ... Threshold 2 = below or above	45 [range from 0 to 50]
Hysteresis	Input X = [AI] ... Threshold 1 = below or above Threshold 2 = below or above	0,4 K [other values in the range 0,2 K ... 3 K]
Cyclic sending interval for thresholds	Input X = [AI] ... Threshold 1 = below or above Threshold 2 = below or above	no sending [other values in the range 30 s ... 120 min]

Object name	Conditions	Dim.	Flags	DPT	No. Comm. Obj.
T delivery (from input 1)		2 Bytes	CR-T--	[9.001] temperature (°C)	18
Threshold temperature 1 sensor (from input 1) - Switch	Input 1 ⇒ Threshold 1 ≠ not active	1 Bit	CR-T--	[1.001] switch	19
Threshold temperature 2 sensor (from input 1) - Switch	Input 1 ⇒ Threshold 2 ≠ not active	1 Bit	CR-T--	[1.001] switch	20

Object name	Conditions	Dim.	Flags	DPT	No. Comm. Obj.
T return (from input 2)	Input 2 = [AI] return temperature sensor	2 Bytes	CR-T--	[9.001] temperature (°C)	21
T generic (from input 2)	Input 2 = [AI] generic (NTC) temperature sensor	2 Bytes	CR-T--	[9.001] temperature (°C)	21
Threshold temperature 1 sensor (from input 2) - Switch	Input 2 ⇒ Threshold 1 ≠ not active	1 Bit	CR-T--	[1.001] switch	22
Threshold temperature 2 sensor (from input 2) - Switch	Input 2 ⇒ Threshold 2 ≠ not active	1 Bit	CR-T--	[1.001] switch	23
T outside (from input 3)	Input 3 = [AI] outside temperature sensor	2 Bytes	CR-T--	[9.001] temperature (°C)	24
T generic (from input 3)	Input 3 = [AI] generic (NTC) temperature sensor	2 Bytes	CR-T--	[9.001] temperature (°C)	24
Threshold temperature 1 sensor (from input 3) - Switch	Input 3 ⇒ Threshold 1 ≠ not active	1 Bit	CR-T--	[1.001] switch	25
Threshold temperature 2 sensor (from input 3) - Switch	Input 3 ⇒ Threshold 2 ≠ not active	1 Bit	CR-T--	[1.001] switch	26
Flow request contact state (from input 4)	General Parameters ⇒ Activation = from binary input or from binary input and from bus	1 Bit	CR-T--	[1.001] switch	27
T generic (from input 4)	General Parameters ⇒ Activation = from bus, Input 4 = [AI] generic (NTC) temperature sensor	2 Bytes	CR-T--	[9.001] temperature (°C)	27
Generic contact state (from input 4)	General Parameters ⇒ Activation = from bus, Input 4 = [DI] generic contact	1 Bit	CR-T--	[1.001] switch	27
Anticondensation sensor state (from input 4)	General Parameters ⇒ Activation = from bus, Input 4 = [DI] anticondensation sensor contact	1 Bit	CR-T--	[1.001] switch	27
Threshold temperature 1 sensor (from input 4) - Switch	Input 4 ⇒ Threshold 1 ≠ not active	1 Bit	CR-T--	[1.001] switch	28
Threshold temperature 2 sensor (from input 4) - Switch	Input 4 ⇒ Threshold 2 ≠ not active	1 Bit	CR-T--	[1.001] switch	29

<i>Object name</i>	<i>Conditions</i>	<i>Dim.</i>	<i>Flags</i>	<i>DPT</i>	<i>No. Comm. Obj.</i>
Cooling/heating state (from input 5)	General Parameters ⇒ Mode switching = from binary input	1 Bit	CR-T--	[1.001] switch	30
T generic (from input 5)	General Parameters ⇒ Mode switching = from bus or from display, Input 5 = [AI] generic (NTC) temperature sensor	2 Bytes	CR-T--	[9.001] temperature (°C)	30
Generic contact state (from input 5)	General Parameters ⇒ Mode switching = from bus or from display, Input 5 = [DI] generic contact	1 Bit	CR-T--	[1.001] switch	30
Anticondensation sensor state (from input 5)	General Parameters ⇒ Mode switching = from bus or from display, Input 5 = [DI] anticondensation sensor contact	1 Bit	CR-T--	[1.001] switch	30
Threshold temperature 1 sensor (from input 5) - Switch	Input 5 ⇒ Threshold 1 ≠ not active	1 Bit	CR-T--	[1.001] switch	31
Threshold temperature 2 sensor (from input 5) - Switch	Input 5 ⇒ Threshold 2 ≠ not active	1 Bit	CR-T--	[1.001] switch	32

8.4 External sensors from bus

This folder performs the following functions:

- ⇒ Configuration of outside temperature data acquisition through a bus communication object. This function is useful when multiple control units are installed and a climatic compensation is in order: a control unit acquires the data through its analog input and sends the information on the bus; the other control units acquire that data from the bus without the need to install more external sensors.
- ⇒ Configuration of max. 16 thermostats or ambient probes on the bus in order to activate the mixing group and realize control types taking into account the internal conditions of the building. These parameters are exposed only if in the *General Parameters* folder the *Activation* parameter is set on "from bus" or "from binary input and from bus". In cooling applications, it is possible to directly connect, for each zone, the communication object carrying the dewpoint temperature data (available in ekinex products); alternatively, the control unit is capable of internally elaborating an estimate of the dewpoint temperature of the single zone, given that the temperature and relative humidity values of the environment are available (2 bytes value [DPT 9.007] or 1 byte [DPT 5.001]).

It is possible to activate the reading at startup and also a data cyclic reading in order to allow a direct synchronization of the control unit on the bus: in case of missing power supply, when power is restored it is not necessary to wait for the data to be synchronized on the bus on change, it is the control unit itself that requests a reading of the data which are relevant in order to perform the configured functions.

The *External sensors from bus* folder is always active.

Parameter name	Conditions	Values
Outside temperature	Inputs ⇒ Input 3 ≠ [AI] outside temperature sensor	disabled / enabled
Reading at start	Outside temperature = enabled	no / yes
Cyclic reading interval	Outside temperature = enabled	no reading [other values in the range 30 s ... 120 min]
[...]		
Zone number	General Parameters ⇒ Activation = from bus or from binary input and from bus	1 [range 1... 16]
Activate internal dewpoint processing	General Parameters ⇒ Activation = from bus or from binary input and from bus and General Parameters ⇒ Function = cooling or heating and cooling	no / yes
Relative humidity comm. object size	Activate internal dewpoint processing = yes	1 byte (DPT 5.001) 2 byte (DPT 9.007)
Cyclic sending interval calculated T dewpoint	Activate internal dewpoint processing = yes	no sending [other values in the range 30 s ... 120 min]
Reading at start	General Parameters ⇒ Activation = from bus or from binary input and from bus	no / yes

Parameter name	Conditions	Values
Cyclic reading interval	General Parameters ⇒ Activation = from bus or from binary input and from bus	no reading [other values in the range 30 s ... 120 min]
Analog sensors timeout		00:05:00 hh:mm:ss [range 00:00:00 ... 18:12:15]
<i>The field has the format hh:mm:ss (hours:minutes:seconds); the default value 00:05:00 therefore corresponds to a 5 minute timeout. The 00:00:00 means that the time-out of analog sensors is deactivated.</i>		

Object name	Conditions	Dim.	Flags	DPT	No. Comm. Obj.
T outside (from bus)	Inputs ⇒ Input 3 ≠ [AI] outside temperature sensor, Outside temperature = enabled	2 Bytes	C-WTU-	[9.001] temperature (°C)	33
Zone X – Command state	General Parameters ⇒ Activation = from bus or from binary input and from bus	1 Bit	C-WTU-	[1.001] switch	70, 75, 80, 85, 90, 95, 100, 105, 110, 115, 120, 125, 130, 135, 140, 145
Zone X – T set current	General Parameters ⇒ Activation = from bus or from binary input and from bus, Heating ⇒ Control type = recalibration based on internal conditions or climatic compensation and recalibration based on internal conditions	2 Bytes	C-WTU-	[9.001] temperature (°C)	71, 76, 81, 86, 91, 96, 101, 106, 111, 116, 121, 126, 131, 136, 141, 146
Zone X – T room	General Parameters ⇒ Activation = from bus or from binary input and from bus, Heating ⇒ Control type = recalibration based on internal conditions or climatic compensation and recalibration based on internal conditions or Cooling ⇒ Control type = recalibration based on internal thermohygrometric conditions or climatic compensation and recalibration based on internal thermohygrometric conditions	2 Bytes	C-WTU-	[9.001] temperature (°C)	72, 77, 82, 87, 92, 97, 102, 107, 112, 117, 122, 127, 132, 137, 142, 147

Object name	Conditions	Dim.	Flags	DPT	No. Comm. Obj.
Zone X – T dew point room	General Parameters ⇒ Activation = from bus or from binary input and from bus, Cooling ⇒ Control type = recalibration based on internal thermohygrometric conditions or climatic compensation and recalibration based on internal thermohygrometric conditions, Activate internal dewpoint processing = no	2 Bytes	C-WTU-	[9.001] temperature (°C)	73, 78, 83, 88, 93, 98, 103, 108, 113, 118, 123, 128, 133, 138, 143, 148
Zone X – Relative humidity (2 bytes)	General Parameters ⇒ Activation = from bus or from binary input and from bus, Cooling ⇒ Control type = recalibration based on internal thermohygrometric conditions or climatic compensation and recalibration based on internal thermohygrometric conditions, Activate internal dewpoint processing = yes, Relative humidity C.O. dimension = 2 byte (DPT 9.007)	2 Bytes	C-WTU-	[9.007] percentage (%)	73, 78, 83, 88, 93, 98, 103, 108, 113, 118, 123, 128, 133, 138, 143, 148
Zone X – Relative humidity (1 byte)	General Parameters ⇒ Activation = from bus or from binary input and from bus, Cooling ⇒ Control type = recalibration based on internal thermohygrometric conditions or climatic compensation and recalibration based on internal thermohygrometric conditions, Activate internal dewpoint processing = yes, Relative humidity C.O. dimension = 1 byte (DPT 5.001)	1 Byte	C-WTU-	[5.001] percentage (0..100%)	73, 78, 83, 88, 93, 98, 103, 108, 113, 118, 123, 128, 133, 138, 143, 148
Zone X – T dew point room	General Parameters ⇒ Activation = from bus or from binary input and from bus, Cooling ⇒ Control type = recalibration based on internal thermohygrometric conditions or climatic compensation and recalibration based on internal thermohygrometric conditions, Activate internal dewpoint processing = yes	1 Byte	CR-T--	[9.001] temperature (°C)	74, 79, 84, 89, 94, 99, 104, 109, 114, 119, 124, 129, 134, 139, 144, 149

8.5 Heating

This folder contains the parameters for configuring the delivery temperature setpoint of the mixing group when conduction mode is heating. Depending on the selected activation mode in the *General Parameters* folder, different algorithm types are available.

If *General Parameters* \Rightarrow *Activation* = *from binary input*, the following control algorithms are available:

- \Rightarrow fixed point
- \Rightarrow climatic compensation
- \Rightarrow recalibration based on return temperature

If *General Parameters* \Rightarrow *Activation* = *from bus* or *from binary input and from bus*, the choice of control algorithms is wider, thanks to the data coming from installed KNX probes:

- \Rightarrow fixed point
- \Rightarrow climatic compensation
- \Rightarrow recalibration based on return temperature
- \Rightarrow recalibration based on internal conditions
- \Rightarrow climatic compensation and recalibration based on internal conditions

This folder is active if *General Parameters* \Rightarrow *Function* = *heating* or *heating and cooling*.

Parameter name	Conditions	Values
Control type	General Parameters \Rightarrow Activation = from binary input	fixed point climatic compensation recalibration based on internal conditions
	<i>If Control type = climatic compensation is selected and no external sensor is configured in Input or External inputs from bus folder, the corresponding setting parameters are not active. A Warning message will indicate that it is necessary to configure the external sensor. Similarly, if Control type = recalibration based on return temperature is selected and no return temperature sensor is configured, the warning will indicate that it is necessary to configure the corresponding sensor.</i>	
Control type	General Parameters \Rightarrow Activation = from bus or from binary input and from bus	fixed point climatic compensation recalibration based on internal conditions recalibration based on return temperature climatic compensation and recalibration based on internal conditions
	<i>Same considerations of the previous parameter apply here, under different conditions. If C.O. relevant to the configured zones (in External sensors from bus folder) are not linked to the corresponding group addresses, the mixing group control does not activate.</i>	
[...]		
Fixed point delivery setpoint [0,1 °C]	Control type = fixed point	350 [range 200 ... 600]
[...]		
Min delivery setpoint [0,1 °C]	Control type = climatic compensation or climatic compensation and recalibration based on internal conditions	300 [range 200 ... 400]
Max delivery setpoint [0,1 °C]	Control type = climatic compensation or climatic compensation and recalibration based on internal conditions	400 [range 300 ... 600]

Parameter name	Conditions	Values
Outside temperature T1, for compensation start [0,1 °C]	Control type = climatic compensation or climatic compensation and recalibration based on internal conditions	180 [range 100 ... 250]
Outside temperature T0, project [0,1 °C]	Control type = climatic compensation or climatic compensation and recalibration based on internal conditions	0 [range -200 ... 100]
[...]		
Project delivery setpoint [0,1 °C]	Control type = recalibration based on return temperature	350 [range 200 ... 600]
ΔT project temperature [0,1 K]	Control type = recalibration based on return temperature	60 [range 10 ... 100]
Min delivery setpoint [0,1 °C]	Control type = recalibration based on return temperature	300 [range 200 ... 400]
Max delivery setpoint [0,1 °C]	Control type = recalibration based on return temperature	400 [range 300 ... 600]
[...]		
Project delivery setpoint [0,1 °C]	Control type = recalibration based on internal conditions	350 [range 200 ... 600]
System inertia [%]	Control type = recalibration based on internal conditions or climatic compensation and recalibration based on internal conditions	60 [range 15 ... 100]
Setpoint change range [0,1 °C]	Control type = recalibration based on internal conditions or climatic compensation and recalibration based on internal conditions	80 [range 10 ... 150]
[...]		
Min change of actual delivery setpoint value to send [°C]		0,2 [range from 0,1 to 2 °C]
	<i>These settings about the sending on the bus of the actual delivery setpoint are also valid in cooling mode.</i>	
Cyclic sending interval for current delivery setpoint		no sending [other values in the range 30 s ... 120 min]
	<i>These settings about the sending on the bus of the actual delivery setpoint are also valid in cooling mode.</i>	
[...]		
Enable overtemperature alarm		no / yes
	<p><i>When an overtemperature alarm is active, the mixing valve is bypassed in order to allow the disposal of the heat, if generated by a transitional situation. If overtemperature stays on for more than 4 minutes, in order to avoid structural damages to the screed for thermal dilatation, the circulator is stopped, too. Its restore is automatic as soon as the delivery temperature rises above the selected alarm threshold.</i></p> <p><i>This function cannot substitute in any way an external safety thermostat, which is a hardware safety solution.</i></p>	

Parameter name	Conditions	Values
Overtemperature alarm setpoint [0,1 °C]	Enable overtemperature alarm = yes	450 [range 400 ... 700]
Enable low temperature message		no / yes
	<i>Indication is carried out by the LED on the front panel of the device, with indication type shown in the Alarm menu of the display. This information is also available through the Alarm Text C.O. The mixing group continues to operate regularly.</i>	
Low temperature indicating setpoint [0,1 °C]	Enable low temperature message= yes	200 [range 100 ... 400]

Object name	Conditions	Dim.	Flags	DPT	No. Comm. Obj.
Current delivery setpoint		2 Bytes	CR-T--	[9.001] temperature (°C)	12
Delivery setpoint offset		2 Bytes	CRWTU-	[9.002] temperature difference (K)	13
	<i>Generally, the setpoint offset is stored in a non-volatile memory. When conduction mode is switched, this offset value is set to 0. This C.O. is used for temporary modifications of the operating setpoint.</i>				
Controller output	Mixing valve output ⇒ Enable valve position feedback = yes	1 Byte	CR-T--	[5.001] percentage (0..100%)	14
Too high delivery T alarm (heating)	Enable overtemperature alarm = yes	1 Bit	CR-T--	[1.005] alarm	5
[...]					
Fixed point delivery setpoint (heating)	Control type = fixed point	2 Bytes	CRWTU-	[9.001] temperature (°C)	47
[...]					
Min delivery setpoint (heating)	Control type = climatic compensation or climatic compensation and recalibration based on internal conditions	2 Bytes	CRWTU-	[9.001] temperature (°C)	48
Max delivery setpoint (heating)	Control type = climatic compensation or climatic compensation and recalibration based on internal conditions	2 Bytes	CRWTU-	[9.001] temperature (°C)	49
T outside T1 (heating)	Control type = climatic compensation or climatic compensation and recalibration based on internal conditions	2 Bytes	CRWTU-	[9.001] temperature (°C)	50

Object name	Conditions	Dim.	Flags	DPT	No. Comm. Obj.
T outside T0 (heating)	Control type = climatic compensation or climatic compensation and recalibration based on internal conditions	2 Bytes	CRWTU-	[9.001] temperature (°C)	51
[...]					
Fixed point delivery setpoint (heating)	Control type = recalibration based on return temperature or recalibration based on internal conditions	2 Bytes	CRWTU-	[9.001] temperature (°C)	47
Project ΔT (heating)	Control type = recalibration based on return temperature	2 Bytes	CRWTU-	[9.002] temperature difference (K)	52
[...]					
Setpoint change (heating)	Control type = recalibration based on internal conditions or climatic compensation and recalibration based on internal conditions	2 Bytes	CRWTU-	[9.001] temperature (°C)	53

8.6 Cooling

This folder contains the parameters for configuring the delivery temperature setpoint of the mixing group when conduction mode is cooling. Depending on the selected activation mode in the *General Parameters* folder, different algorithm types are available.

If *General Parameters* \Rightarrow *Activation* = *from binary input*, the following control algorithms are available:

- \Rightarrow fixed point
- \Rightarrow climatic compensation

If *General Parameters* \Rightarrow *Activation* = *from bus* or *from binary input and from bus*, the choice of control algorithms is wider, thanks to the data coming from installed KNX probes:

- \Rightarrow fixed point
- \Rightarrow climatic compensation
- \Rightarrow recalibration based on internal thermohygrometric conditions
- \Rightarrow climatic compensation and recalibration based on internal thermohygrometric conditions

This folder is active if *General Parameters* \Rightarrow *Function* = *heating* or *heating and cooling*.

Parameter name	Conditions	Values
Control type	General Parameters \Rightarrow Activation = from binary input	fixed point climatic compensation
	<i>If Control type = climatic compensation is selected and no external sensor is configured in Input or External inputs from bus folder, the corresponding setting parameters are not active. A Warning message will indicate that it is necessary to configure the external sensor.</i>	
Control type	General Parameters \Rightarrow Activation = from bus or from binary input and from bus	fixed point climatic compensation recalibration based on internal thermohygrometric conditions climatic compensation and recalibration based on internal thermohygrometric conditions
	<i>Same considerations of the previous parameter apply here, under different conditions. If C.O. relevant to the configured zones are not linked to the corresponding group addresses, the mixing group control does not activate.</i>	
[...]		
Fixed point delivery setpoint [0,1 °C]	Control type = fixed point	160 [range 70 ... 250]
[...]		
Min delivery setpoint [0,1 °C]	Control type = climatic compensation or climatic compensation and recalibration based on internal thermohygrometric conditions	160 [range 70 ... 250]
Max delivery setpoint [0,1 °C]	Control type = climatic compensation or climatic compensation and recalibration based on internal thermohygrometric conditions	200 [range 150 ... 300]
Outside temperature T2, for compensation start [0,1 °C]	Control type = climatic compensation or climatic compensation and recalibration based on internal thermohygrometric conditions	250 [range 200 ... 400]

Parameter name	Conditions	Values
Outside temperature T3, project [0,1 °C]	Control type = climatic compensation o climatic compensation and recalibration based on internal thermohygrometric conditions	350 [range 200 ... 400]
[...]		
Project delivery setpoint [0,1 °C]	Control type = recalibration based on internal thermohygrometric conditions	160 [range 70 ... 250]
Safety value [0,1 °C]	Control type = ritatura sulle condizioni termohigrometriche interne o climatic compensation and recalibration based on internal thermohygrometric conditions	15 [range -50 ... 50]
[...]		
Enable anticondensation alarm		no / yes
	<i>If no anticondensation probe is configured in Input folder, the corresponding parameters about the alarm management do not activate. A warning message will indicate that it is necessary to configure at least one anticondensation probe.</i>	
Circulator lock	Enable anticondensation alarm = yes	no / yes
Set mixing valve to bypass	Enable anticondensation alarm = yes e Circulator lock = no	no / yes
[...]		
Min change of actual delivery setpoint value to send [°C]	General Parameters ⇒ Function = cooling	0,2 [range from 0,1 to 2 °C]
Cyclic sending interval for current delivery setpoint	General Parameters ⇒ Function = cooling	no sending [other values in the range 30 s ... 120 min]
[...]		
Min change of max T dewpoint value to send [K]	Control type = recalibration based on internal thermohygrometric conditions or climatic compensation and recalibration based on internal thermohygrometric conditions	0,5 [range from 0 to 5]
Cyclic sending interval max T dewpoint	Control type = recalibration based on internal thermohygrometric conditions or climatic compensation and recalibration based on internal thermohygrometric conditions	no sending [other values in the range 30 s ... 120 min]
[...]		
Enable undertemperature alarm		no / yes
	<i>When an undertemperature alarm is active, the mixing valve is bypassed in order to allow the disposal of the refrigeration units, if generated by a transitional situation. If undertemperature stays on for more than 4 minutes, in order to avoid condensation on the radiating surfaces, the circulator is stopped, too. Its restore is automatic as soon as the delivery temperature rises above the selected alarm threshold.</i>	

Parameter name	Conditions	Values
Undertemperature alarm setpoint [0,1 °C]	Enable undertemperature message = yes	130 [range 90 ... 200]
Enable high temperature message		no / yes
	<i>Indication is carried out by the LED on the front panel of the device, with indication type shown in the Alarm menu of the display. This information is also available through the Alarm Text C.O. The mixing group continues to operate regularly.</i>	
High temperature indicating setpoint [0,1 °C]	Enable high temperature message = yes	250 [range 200 ... 300]

Object name	Conditions	Dim.	Flags	DPT	No. Comm. Obj.
Current delivery setpoint		2 Bytes	CR-T--	[9.001] temperature (°C)	12
Delivery setpoint offset		2 Bytes	CRWTU-	[9.002] temperature difference (K)	13
	<i>Generally, the setpoint offset is stored in a non-volatile memory. When conduction mode is switched, this offset value is set to 0. This C.O. is used for temporary modifications of the operating setpoint.</i>				
Controller output	Mixing valve output ⇒ Enable valve position feedback = yes	1 Byte	CR-T--	[5.001] percentage (0..100%)	14
T dew point max	Control type = recalibration based on internal thermohygrometric conditions or climatic compensation and recalibration based on internal thermohygrometric conditions	2 Bytes	CR-T--	[9.001] temperature (°C)	17
Too low delivery T alarm (cooling)	Enable undertemperature message = yes	1 Bit	CR-T--	[1.005] alarm	6
[...]					
Fixed point delivery setpoint (cooling)	Control type = fixed point	2 Bytes	CR-T--	[9.001] temperature (°C)	54
[...]					
Min delivery setpoint (cooling)	Control type = climatic compensation or climatic compensation and recalibration based on internal thermohygrometric conditions	2 Bytes	CR-T--	[9.001] temperature (°C)	55

Object name	Conditions	Dim.	Flags	DPT	No. Comm. Obj.
Max delivery setpoint (cooling)	Control type = climatic compensation or climatic compensation and recalibration based on internal thermohygrometric conditions	2 Bytes	CR-T--	[9.001] temperature (°C)	56
T outside T2 (cooling)	Control type = climatic compensation or climatic compensation and recalibration based on internal thermohygrometric conditions	2 Bytes	CR-T--	[9.001] temperature (°C)	57
T outside T3 (cooling)	Control type = climatic compensation or climatic compensation and recalibration based on internal thermohygrometric conditions	2 Bytes	CR-T--	[9.001] temperature (°C)	58
[...]					
Fixed point delivery setpoint (cooling)	Control type = recalibration based on internal thermohygrometric conditions	2 Bytes	CR-T--	[9.001] temperature (°C)	54
Safety value (cooling)	Control type = recalibration based on internal thermohygrometric conditions or climatic compensation and recalibration based on internal thermohygrometric conditions	2 Bytes	CR-T--	[9.001] temperature (°C)	59

8.7 Mixing valve output

The *Mixing valve output* folder is always active and contains the parameters for the configuration of the mixing valve and the circulator.

In this folder it is possible to setup the following parameters:

- Selection of the type of servomotor to be paired to the mixing valve: 3 point floating or 0-10 V
- Mixing valve opening time
- PI (proportional-integral) controller parameters for delivery temperature control
- Enable circulator protection function

NOTE: communication objects for output state, disabling and remote command.

The following criteria are adopted:

- ⇒ The output remote command C.O.s do not concern DO1 output which is always meant for the circulator. DO2 and DO3 outputs have a corresponding remote command C.O. if they are not associated to logic function outputs. TR1, TR2 and 0... 10V outputs have a remote command C.O. if they are not used, i.e. depending on *Servomotor control* parameter.
- ⇒ State and disabling from bus C.O.s are not exposed when the corresponding C.O.s for output remote command are exposed.
- ⇒ State and disabling from bus C.O.s are exposed if the output is managed by an internal logic.

Parameter name	Conditions	Values
Servomotor control		3 point floating with 0-10V control signal
Servomotor fullstroke time	Servomotor control = 3 point floating	145 s [other values in the range 0 ... 255 s]
Proportional band [0,1 K]		150 [range 5 ... 500]
Integral time [s]		600 [range 10 ... 1500]
Dead band [0.1 K]		2 [range 0 ... 10]
[...]	<i>Dead band is an error interval where the integral action is "frozen" and therefore is not involved in the regulation, in order to reduce the stress on the mixing valve servomotor. A Dead band = 0 K means that the integral action is always active until the delivery setpoint is reached.</i>	
Enable circulator protection function		no / yes
Frequency	Enable circulator protection function = yes	once a day, once a week , once a month
Time interval	Enable circulator protection function = yes	10 s [other values in the range 5 s ... 20 min]

Parameter name	Conditions	Values
[...]		
Enable manual mode		no / yes
	<i>This parameter allows commanding the controller output in automatic/manual mode.</i>	
[...]		
Disable circulator from bus		no / yes
Signal from bus	Disable circulator from bus = yes	not inverted inverted
[...]		
Disable valve from bus		no / yes
Signal from bus	Disable valve from bus = yes	not inverted inverted
[...]		
Enable valve position feedback		no / yes
Min change of value to send [%]	Enable valve position feedback = yes	3 [range from 3 to 10%]
Cyclic sending interval	Enable valve position feedback = yes	no sending [other values in the range 30 s ... 120 min]

Object name	Conditions	Dim.	Flags	DPT	No. Comm. Obj.
Current delivery setpoint		2 Bytes	CR-T--	[9.001] temperature (°C)	12
Delivery setpoint offset		2 Bytes	CRWTU-	[9.002] temperature difference (K)	13
	<i>Generally, the setpoint offset is stored in a non-volatile memory. When conduction mode is switched, this offset value is set to 0. This C.O. is used for temporary modifications of the operating setpoint.</i>				
Controller output	Enable valve position feedback = yes	1 Byte	CR-T--	[5.001] percentage (0..100%)	14
Percentage controller output manual control	Enable manual mode = yes	1 Byte	C-W---	[5.001] percentage (0..100%)	15
Automatic/manual controller output from bus	Enable manual mode = yes	1 Bit	CRWT--	[1.003] enable	16
Circulator output DO1 state		1 Bit	CR-T--	[1.001] switch	34
Disable circulator output DO1 from bus	Disable circulator from bus = yes	1 Bit	C-W---	[1.003] enable	37
	<i>This C.O. is retained, its state is maintained after a bus voltage failure.</i>				

Object name	Conditions	Dim.	Flags	DPT	No. Comm. Obj.
Disable output TR1/TR2 from bus	Disable valve from bus = yes, Servomotor control = 3 point floating	1 Bit	C-W---	[1.003] enable	40
<i>This C.O. is retained, its state is maintained after a bus voltage failure.</i>					
Disable output 0-10V from bus	Disable valve from bus = yes, Servomotor control = with 0-10V control signal	1 Bit	C-W---	[1.003] enable	41
<i>This C.O. is retained, its state is maintained after a bus voltage failure.</i>					

8.8 Logic functions

This folder allows the realization of logic functions and linking the logic outputs to DO2 and DO3 physical outputs. It is also possible to control a high temperature circulator (for radiators or fancoils) installed in the technical compartment where the control unit is installed, by performing a logic OR of max. 16 heat requests on bus. Moreover, it is possible to control a zone valve that intercepts the circuits for incoming fluids (centralized plants, condos).

The output of the logic function, both on C.O. and DO2/DO3 physical outputs, can be delayed with a configurable time.

The folder is active if *General Parameters* ⇒ *Logic functions* = enabled.

Parameter name	Conditions	Values
Logic function X		disabled enabled
Logic operation	Logic function = enabled <i>XOR (eXclusive OR)</i>	OR / AND / XOR
Activation delay [s]		180 s [other values in the range 0 ... 255 s]
Output cyclic transmission interval	Enable logic function output state = yes <i>No sending means that the output state of the logic function is updated on the bus only on change. Different values imply cyclic sending on the bus of the output state.</i>	no sending [other values in the range 30 s ... 120 min]
Logic object x		disabled enabled
	<i>x from 1 to 16</i>	
Logic object x negated	Logic object x = enabled <i>By negating the logic state of the corresponding object, it is possible to create complex combinatory logics. For example: Output= (NOT(Logic object 1) OR Logic object 2).</i>	no / yes
Logic object x read at startup	Logic object x = enabled	no / yes
Logic object x default value	Logic object x = enabled	none / off / on
[...]		
DO2 physical output control	Logic function 1 = enabled	no / yes
Disable output from bus	DO2 output control from bus = yes	no / yes
Signal from bus	DO2 output control from bus = yes	not inverted inverted
[...]		
DO3 physical output control	Logic function 2 = enabled	no / yes
Disable output from bus	DO3 output control from bus = yes	no / yes
Signal from bus	DO3 output control from bus = yes	not inverted inverted

Parameter name	Conditions	Values
[...]		
Delay after bus voltage recovery		00:00:04.000 hh:mm:ss.fff [range 00:00:00.000 ... 00:10:55.350]
	<i>Time interval between the bus voltage recovery and the first reading of the input communication objects for evaluating the logic functions.</i>	

Object name	Conditions	Dim.	Flags	DPT	No. Comm. Obj.
Logic function X – Input 1	Logic function X = enabled Logic object 1 = enabled	1 Bit	C-WTU-	[1.001] switch	150, 167
	The logic output is not calculated if all input communication objects do not receive a value from bus.				
Logic function X – Input 2	Logic function X = enabled Logic object 2 = enabled	1 Bit	C-WTU-	[1.001] switch	151, 168
Logic function X – Input 3	Logic function X = enabled Logic object 3 = enabled	1 Bit	C-WTU-	[1.001] switch	152, 169
Logic function X – Input 4	Logic function X = enabled Logic object 4 = enabled	1 Bit	C-WTU-	[1.001] switch	153, 170
Logic function X – Input 5	Logic function X = enabled Logic object 5 = enabled	1 Bit	C-WTU-	[1.001] switch	154, 171
Logic function X – Input 6	Logic function X = enabled Logic object 6 = enabled	1 Bit	C-WTU-	[1.001] switch	155, 172
Logic function X – Input 7	Logic function X = enabled Logic object 7 = enabled	1 Bit	C-WTU-	[1.001] switch	156, 173
Logic function X – Input 8	Logic function X = enabled Logic object 8 = enabled	1 Bit	C-WTU-	[1.001] switch	157, 174
Logic function X – Input 9	Logic function X = enabled Logic object 9 = enabled	1 Bit	C-WTU-	[1.001] switch	158, 175
Logic function X – Input 10	Logic function X = enabled Logic object 10 = enabled	1 Bit	C-WTU-	[1.001] switch	159, 176
Logic function X – Input 11	Logic function X = enabled Logic object 11 = enabled	1 Bit	C-WTU-	[1.001] switch	160, 177
Logic function X – Input 12	Logic function X = enabled Logic object 12 = enabled	1 Bit	C-WTU-	[1.001] switch	161, 178
Logic function X – Input 13	Logic function X = enabled Logic object 13 = enabled	1 Bit	C-WTU-	[1.001] switch	162, 179
Logic function X – Input 14	Logic function X = enabled Logic object 14 = enabled	1 Bit	C-WTU-	[1.001] switch	163, 180

<i>Object name</i>	<i>Conditions</i>	<i>Dim.</i>	<i>Flags</i>	<i>DPT</i>	<i>No. Comm. Obj.</i>
Logic function X – Input 15	Logic function X = enabled Logic object 15 = enabled	1 Bit	C-WTU-	[1.001] switch	164, 181
Logic function X – Input 16	Logic function X = enabled Logic object 16 = enabled	1 Bit	C-WTU-	[1.001] switch	165, 182
Logic function X – Output	Logic function X = enabled Logic object 1 = enabled	1 Bit	CR-T--	[1.001] switch	166, 183
DO2 output state	DO2 output control from bus = yes	1 Bit	CR-T--	[1.001] switch	35
DO3 output state	DO3 output control from bus = yes	1 Bit	CR-T--	[1.001] switch	36
Disable output DO2 from bus	DO2 output control from bus = yes, Disable output from bus = yes	1 Bit	C-W---	[1.003] enable	38
Disable output DO3 from bus	DO3 output control from bus = yes, Disable output from bus = yes	1 Bit	C-W---	[1.003] enable	39

9 Appendix

9.1 List of KNX communication objects

The following table is filled with all KNX communication objects with their corresponding *Data Point Types* (DPT) defined in the application program, based on the present configuration.

The list is sorted by object number; in case of same objects related to different inputs, the first input number is relevant.

No.	Communication object name	Size	Flag	Data Point Type
Alarms				
0	Technical alarm	1 Bit	R-CT--	[1.5] DPT_Alarm
1	Communication alarm	1 Bit	R-CT--	[1.5] DPT_Alarm
2	Thermal generator lock	1 Bit	-WC---	[1.5] DPT_Alarm
3	Power off alarm	1 Bit	R-CT--	[1.5] DPT_Alarm
4	Temperature control alarm	1 Bit	R-CT--	[1.5] DPT_Alarm
5	Too high delivery T alarm (heating)	1 Bit	R-CT--	[1.5] DPT_Alarm
6	Too low delivery T alarm (cooling)	1 Bit	R-CT--	[1.5] DPT_Alarm
7	Alarm text	14 Bytes	R-CT--	[16.0] DPT_String_ASCII
Membrane keyboard command				
8	Test mode activated	1 Bit	R-CT--	[1.3] DPT_Enable
9	Disable front keyboard	1 Bit	-WC---	[1.2] DPT_Bool
Miscellanea				
10	Heating/cooling changeover in	1 Bit	-WC---	[1.100] DPT_Heat_Cool
11	Heating/cooling changeover out	1 Bit	R-CT--	[1.100] DPT_Heat_Cool
Mixing group monitoring and manual command				
12	Current delivery setpoint	2 Bytes	R-CT--	[9.1] DPT_Value_Temp
13	Delivery setpoint offset	2 Bytes	RWCTU-	[9.2] DPT_Value_Tempd
14	Controller output	1 Byte	R-CT--	[5.1] DPT_Scaling
15	Percentage controller output manual control	1 Byte	-WC---	[5.1] DPT_Scaling
16	Automatic/manual controller output from bus	1 Bit	RWCT--	[1.3] DPT_Enable
17	T dew point max	2 Bytes	R-CT--	[9.1] DPT_Value_Temp
Digital/analog signals				
18	T delivery (from input 1)	2 Bytes	R-CT--	[9.1] DPT_Value_Temp
19	Threshold temperature 1 sensor (from input 1) - Switch	1 Bit	R-CT--	[1.1] DPT_Switch
20	Threshold temperature 2 sensor (from input 1) - Switch	1 Bit	R-CT--	[1.1] DPT_Switch
21	T return (from input 2)	2 Bytes	R-CT--	[9.1] DPT_Value_Temp
21	T generic (from input 2)	2 Bytes	R-CT--	[9.1] DPT_Value_Temp
22	Threshold temperature 1 sensor (from input 2) - Switch	1 Bit	R-CT--	[1.1] DPT_Switch
23	Threshold temperature 2 sensor (from input 2) - Switch	1 Bit	R-CT--	[1.1] DPT_Switch

No.	Communication object name	Size	Flag	Data Point Type
24	T outside (from input 3)	2 Bytes	R-CT--	[9.1] DPT_Value_Temp
24	T generic (from input 3)	2 Bytes	R-CT--	[9.1] DPT_Value_Temp
25	Threshold temperature 1 sensor (from input 3) - Switch	1 Bit	R-CT--	[1.1] DPT_Switch
26	Threshold temperature 2 sensor (from input 3) - Switch	1 Bit	R-CT--	[1.1] DPT_Switch
27	T generic (from input 4)	2 Bytes	R-CT--	[9.1] DPT_Value_Temp
27	Flow request contact state (from input 4)	1 Bit	R-CT--	[1.1] DPT_Switch
27	Anticondensation sensor state (from input 4)	1 Bit	R-CT--	[1.1] DPT_Switch
27	Generic contact state (from input 4)	1 Bit	R-CT--	[1.1] DPT_Switch
28	Threshold temperature 1 sensor (from input 4) - Switch	1 Bit	R-CT--	[1.1] DPT_Switch
29	Threshold temperature 2 sensor (from input 4) - Switch	1 Bit	R-CT--	[1.1] DPT_Switch
30	T generic (from input 5)	2 Bytes	R-CT--	[9.1] DPT_Value_Temp
30	Cooling/heating state (from input 5)	1 Bit	R-CT--	[1.1] DPT_Switch
30	Anticondensation sensor state (from input 5)	1 Bit	R-CT--	[1.1] DPT_Switch
30	Generic contact state (from input 5)	1 Bit	R-CT--	[1.1] DPT_Switch
31	Threshold temperature 1 sensor (from input 5) - Switch	1 Bit	R-CT--	[1.1] DPT_Switch
32	Threshold temperature 2 sensor (from input 5) - Switch	1 Bit	R-CT--	[1.1] DPT_Switch
Inputs from bus				
33	T outside (from bus)	2 Bytes	-WCTU-	[9.1] DPT_Value_Temp
Output status				
34	Circulator output DO1 state	1 Bit	R-CT--	[1.1] DPT_Switch
35	DO2 output state	1 Bit	R-CT--	[1.1] DPT_Switch
36	DO3 output state	1 Bit	R-CT--	[1.1] DPT_Switch
Disable outputs from bus				
37	Disable circulator output DO1 from bus	1 Bit	-WC---	[1.3] DPT_Enable
38	Disable output DO2 from bus	1 Bit	-WC---	[1.3] DPT_Enable
39	Disable output DO3 from bus	1 Bit	-WC---	[1.3] DPT_Enable
40	Disable output TR1/TR2 from bus	1 Bit	-WC---	[1.3] DPT_Enable
41	Disable output 0-10V from bus	1 Byte	-WC---	[1.3] DPT_Enable
Remote commands for unused outputs				
42	DO2 output control from bus	1 Bit	-WC---	[1.1] DPT_Switch
43	DO3 output control from bus	1 Bit	-WC---	[1.1] DPT_Switch
44	TR1 control from bus	1 Bit	-WC---	[1.1] DPT_Switch
45	TR2 control from bus	1 Bit	-WC---	[1.1] DPT_Switch
46	0-10V output control from bus	1 Byte	-WC---	[5.1] DPT_Scaling
Parameters				
47	Fixed point delivery setpoint (heating)	2 Bytes	RWCTU-	[9.1] DPT_Value_Temp
48	Min delivery setpoint (heating)	2 Bytes	RWCTU-	[9.1] DPT_Value_Temp

No.	Communication object name	Size	Flag	Data Point Type
49	Max delivery setpoint (heating)	2 Bytes	RWCTU-	[9.1] DPT_Value_Temp
50	T outside T1 (heating)	2 Bytes	RWCTU-	[9.1] DPT_Value_Temp
51	T outside T0 (heating)	2 Bytes	RWCTU-	[9.1] DPT_Value_Temp
52	Project ΔT (heating)	2 Bytes	RWCTU-	[9.1] DPT_Value_Temp
53	Setpoint change (heating)	2 Bytes	RWCTU-	[9.1] DPT_Value_Temp
54	Fixed point delivery setpoint (cooling)	2 Bytes	RWCTU-	[9.1] DPT_Value_Temp
55	Min delivery setpoint (cooling)	2 Bytes	RWCTU-	[9.1] DPT_Value_Temp
56	Max delivery setpoint (cooling)	2 Bytes	RWCTU-	[9.1] DPT_Value_Temp
57	T outside T2 (cooling)	2 Bytes	RWCTU-	[9.1] DPT_Value_Temp
58	T outside T3 (cooling)	2 Bytes	RWCTU-	[9.1] DPT_Value_Temp
59	Safety value (cooling)	2 Bytes	RWCTU-	[9.1] DPT_Value_Temp
Zones				
70, 75, 80, 85, 90, 95, 100, 105, 110, 115, 120, 125, 130, 135, 140, 145	Zone X - Command state	1 Bit	-WCTU-	[1.1] DPT_Switch
71, 76, 81, 86, 91, 96, 101, 106, 111, 116, 121, 126, 131, 136, 141, 146	Zone X - T set current	2 Bytes	-WCTU-	[9.1] DPT_Value_Temp
72, 77, 82, 87, 92, 97, 102, 107, 112, 117, 122, 127, 132, 137, 142, 147	Zone X - T room	2 Bytes	-WCTU-	[9.1] DPT_Value_Temp
73, 78, 83, 88, 93, 98, 103, 108, 113, 118, 123, 128, 133, 138, 143, 148	Zone X - Relative humidity (2 bytes)	2 Bytes	-WCTU-	[9.7] DPT_Value_Humidity
73, 78, 83, 88, 93, 98, 103, 108, 113, 118, 123, 128, 133, 138, 143, 148	Zone X - Relative humidity (1 byte)	1 Byte	-WCTU-	[5.1] DPT_Scaling
73, 78, 83, 88, 93, 98, 103, 108, 113, 118, 123, 128, 133, 138, 143, 148	Zone X - T dew point room	2 Bytes	-WCTU-	[9.1] DPT_Value_Temp
74, 79, 84, 89, 94, 99, 104, 109, 114, 119, 124, 129, 134, 139, 144, 149	Zone X - T dew point room	2 Bytes	R-CT--	[9.1] DPT_Value_Temp
Logic functions				
150, 167	Logic function X – Input 1	1 Bit	-WCTU-	[1.1] DPT_Switch
151, 168	Logic function X – Input 2	1 Bit	-WCTU-	[1.1] DPT_Switch
152, 169	Logic function X – Input 3	1 Bit	-WCTU-	[1.1] DPT_Switch
153, 170	Logic function X – Input 4	1 Bit	-WCTU-	[1.1] DPT_Switch

No.	Communication object name	Size	Flag	Data Point Type
154, 171	Logic function X – Input 5	1 Bit	-WCTU-	[1.1] DPT_Switch
155, 172	Logic function X – Input 6	1 Bit	-WCTU-	[1.1] DPT_Switch
156, 173	Logic function X – Input 7	1 Bit	-WCTU-	[1.1] DPT_Switch
157, 174	Logic function X – Input 8	1 Bit	-WCTU-	[1.1] DPT_Switch
158, 175	Logic function X – Input 9	1 Bit	-WCTU-	[1.1] DPT_Switch
159, 176	Logic function X – Input 10	1 Bit	-WCTU-	[1.1] DPT_Switch
160, 177	Logic function X – Input 11	1 Bit	-WCTU-	[1.1] DPT_Switch
161, 178	Logic function X – Input 12	1 Bit	-WCTU-	[1.1] DPT_Switch
162, 179	Logic function X – Input 13	1 Bit	-WCTU-	[1.1] DPT_Switch
163, 180	Logic function X – Input 14	1 Bit	-WCTU-	[1.1] DPT_Switch
164, 181	Logic function X – Input 15	1 Bit	-WCTU-	[1.1] DPT_Switch
165, 182	Logic function X – Input 16	1 Bit	-WCTU-	[1.1] DPT_Switch
166, 183	Logic function X – Output	1 Bit	R-CT--	[1.1] DPT_Switch

9.2 Retained communication objects

The C.O. listed in this table retain their own state or value in a non-volatile memory even after a KNX bus voltage failure.

No.	Communication object name	Size	Flag	Data Point Type	C.O. state in retained memory
9	Disable front keyboard	1 Bit	-WC---	[1.2] DPT_Bool	X
10	Heating/cooling changeover in	1 Bit	-WC---	[1.100] DPT_Heat_Cool	X
37	Disable circulator output DO1 from bus	1 Bit	-WC---	[1.3] DPT_Enable	X
38	Disable output DO2 from bus	1 Bit	-WC---	[1.3] DPT_Enable	X
39	Disable output DO3 from bus	1 Bit	-WC---	[1.3] DPT_Enable	X
40	Disable output TR1/TR2 from bus	1 Bit	-WC---	[1.3] DPT_Enable	X
41	Disable output 0-10V from bus	1 Byte	-WC---	[1.3] DPT_Enable	X
47	Fixed point delivery setpoint (heating)	2 Bytes	RWCTU-	[9.1] DPT_Value_Temp	X
48	Min delivery setpoint (heating)	2 Bytes	RWCTU-	[9.1] DPT_Value_Temp	X
49	Max delivery setpoint (heating)	2 Bytes	RWCTU-	[9.1] DPT_Value_Temp	X
50	T outside T1 (heating)	2 Bytes	RWCTU-	[9.1] DPT_Value_Temp	X
51	T outside T0 (heating)	2 Bytes	RWCTU-	[9.1] DPT_Value_Temp	X
52	Project ΔT (heating)	2 Bytes	RWCTU-	[9.1] DPT_Value_Temp	X
53	Setpoint change (heating)	2 Bytes	RWCTU-	[9.1] DPT_Value_Temp	X
54	Fixed point delivery setpoint (cooling)	2 Bytes	RWCTU-	[9.1] DPT_Value_Temp	X
55	Min delivery setpoint (cooling)	2 Bytes	RWCTU-	[9.1] DPT_Value_Temp	X
56	Max delivery setpoint (cooling)	2 Bytes	RWCTU-	[9.1] DPT_Value_Temp	X
57	T outside T2 (cooling)	2 Bytes	RWCTU-	[9.1] DPT_Value_Temp	X
58	T outside T3 (cooling)	2 Bytes	RWCTU-	[9.1] DPT_Value_Temp	X
59	Safety value (cooling)	2 Bytes	RWCTU-	[9.1] DPT_Value_Temp	X

9.3 Error indications

The C.O. with index 22, *Alarm Text*, contains the indication code of the latest detected or returned alarm. The following list shows all managed alarm codes.

Alarm code	Cause
Allarmi generali	
A01	Technical alarm
A02	Communication alarm
A03	Thermal generator lock
A04	Power off alarm
A05	Temperature control alarm
A06	Too high delivery T alarm (heating)
A07	Too low delivery T alarm (cooling)
A08	Condensation alarm
Indication code	Cause
S01	Too low delivery T information (heating)
S02	Too high delivery T information (cooling)
Error code	Cause
Allarmi ingressi analogici	
E00	Delivery temperature failure (from input 1)
E01	Return temperature failure (from input 2)
E02	Generic temperature failure (from input 2)
E03	Extern temperature failure (from input 3)
E04	Generic temperature failure (from input 3)
E05	Generic temperature failure (from input 4)
E06	Generic temperature failure (from input 5)
Error code	Cause
Allarmi ingressi da bus	
E07	Extern temperature failure (from bus)
E08	Extern temperature timeout (from bus)
E20, E40, E60, E80, E100, E120, E140, E160, E180, E200, E220, E240, E260, E280, E300, E320	Zone X – Actual setpoint failure
E21, E41, E61, E81, E101, E121, E141, E161, E181, E201, E221, E241, E261, E281, E301, E321	Zone X – Room temperature failure
E22, E42, E62, E82, E102, E122, E142, E162, E182, E202, E222, E242, E262, E282, E302, E322	Zone X – Relative humidity failure
E23, E43, E63, E83, E103, E123, E143, E163, E183, E203, E223, E243, E263, E283, E303, E323	Zone X – Dewpoint temperature failure
E24, E44, E64, E84, E104, E124, E144, E164, E184, E204, E224, E244, E264, E284, E304, E324	Zone X – Command state timeout
E25, E45, E65, E85, E105, E125, E145, E165, E185, E205, E225, E245, E265, E285, E305, E325	Zone X – Actual setpoint timeout
E26, E46, E66, E86, E106, E126, E146, E166, E186, E206, E226, E246,	Zone X – Room temperature timeout

E266, E286, E306, E326	
E27, E47, E67, E87, E107, E127, E147, E167, E187, E207, E227, E247, E267, E287, E307, E327	Zone X – Relative humidity timeout
E28, E48, E68, E88, E108, E128, E148, E168, E188, E208, E228, E248, E268, E288, E308, E328	Zone X – Dewpoint temperature timeout

9.4 Application examples

Here are some application examples of connection and use of the EK-HH1-TP controller.

<ol style="list-style-type: none"> 1) Heat generator 2) Mixing valve 3) Circulator 4) Immersion delivery temperature sensor 5) Immersion delivery temperature sensor (safety) 6) Safety thermostat 	<ol style="list-style-type: none"> 7) Outside temperature sensor 8) Power supply 230 Vac, 50/60 Hz 9) Power supply 24 Vac, 50/60 Hz
--	--

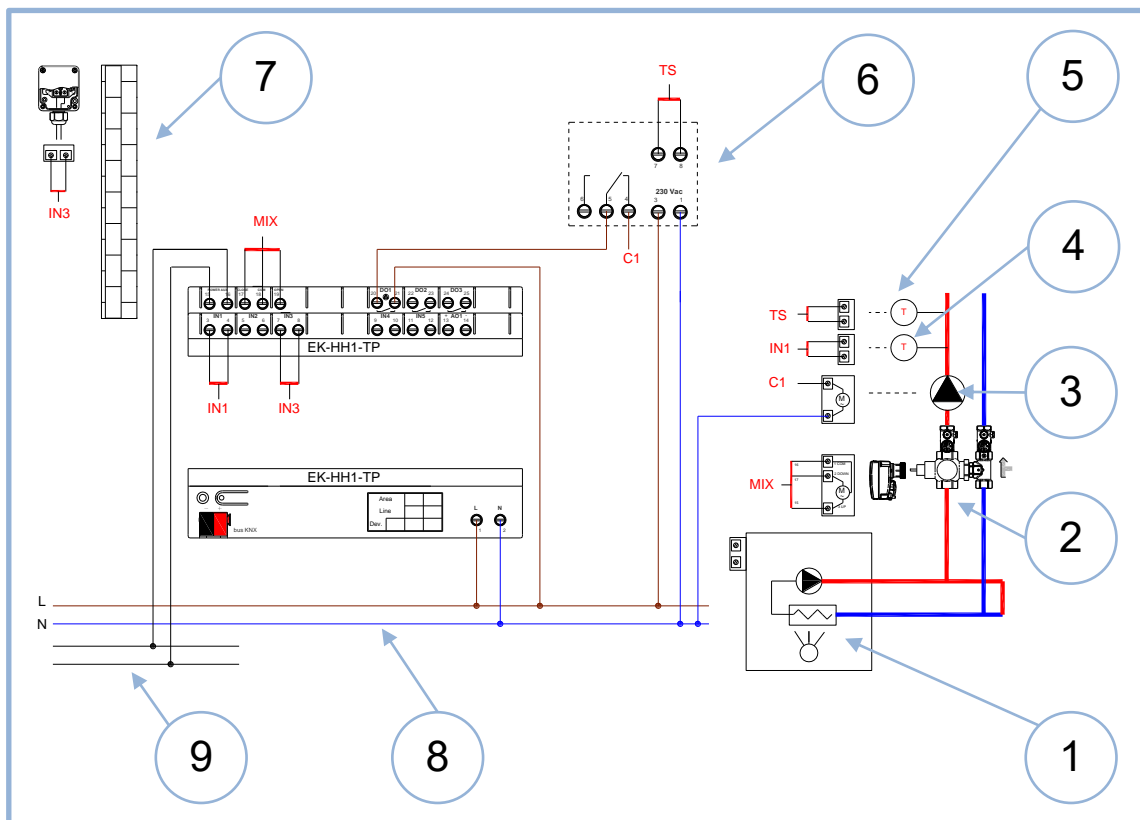

Use of 3 point floating servomotor, power supply 230 Vac: the auxiliary 230Vac power supply is supplied at terminals 15-16. The MIX triac outputs, mutually interlocked, take the power supply directly to the servomotor. In this application, a climatic compensation is performed by connecting an immersion temperature sensor (IN1 input, terminals 3-4) in a manhole on delivery (after the circulator) and connecting an outside temperature sensor (IN3 input, terminals 7-8).

The 3 remaining inputs can be used to monitor the temperature of fluids inside the technical compartment or to connect some voltage-free binary inputs such as flow request or external clock to activate a time scheduling.

The DO1 output (terminals 20-21) is dedicated to control the circulator on the mixing group; the remaining outputs DO2 and DO2, as well as the 0-10V analog output signal, can be used for additional commands.



The EK-HH1-TP controller is fitted with a delivery overtemperature alarm using the same immersion sensor as the regulation. In radiant floor heating applications, in combination with high temperature heat generators, installing an external safety thermostat in series with the circulator command is highly advised, in order to properly protect both the screed and the coating.

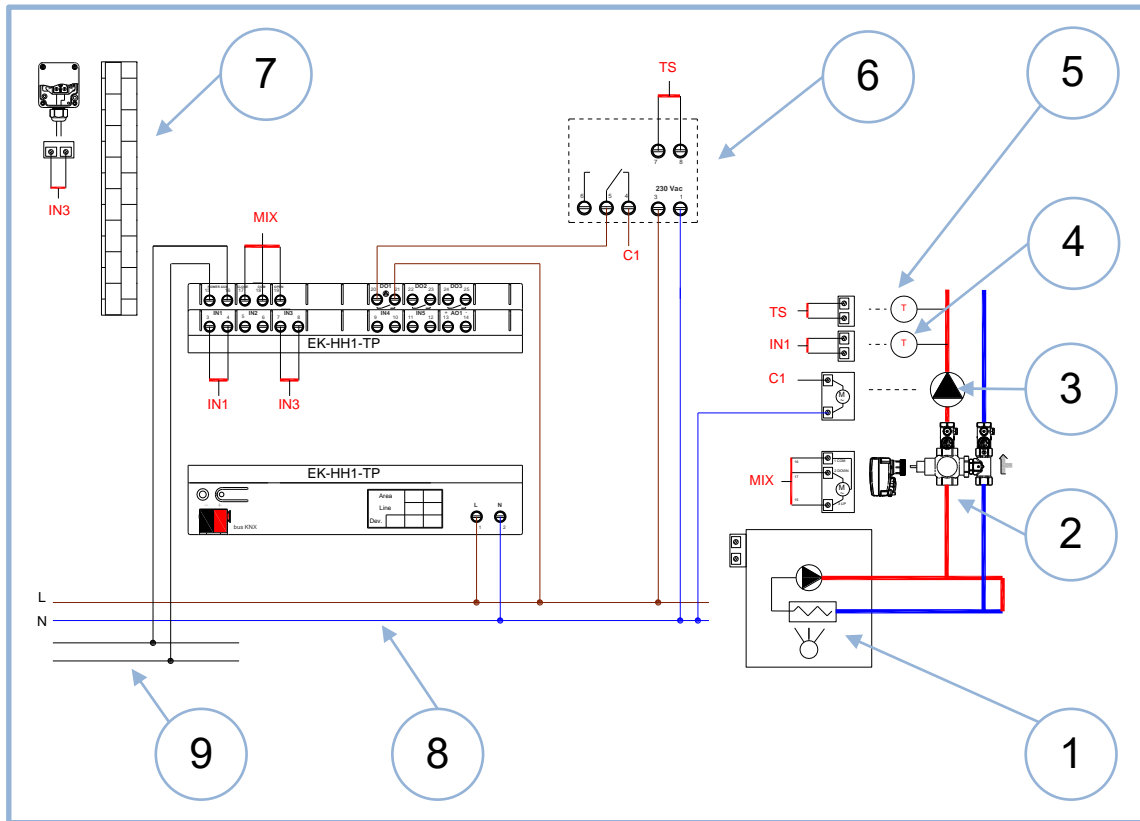

Use of 3 point floating servomotor, power supply 24 Vac: the auxiliary 24Vac power supply is supplied at terminals 15-16. The MIX triac outputs, mutually interlocked, take the power supply directly to the servomotor. In this application, a climatic compensation is performed by connecting an immersion temperature sensor (IN1 input, terminals 3-4) in a manhole on delivery (after the circulator) and connecting an outside temperature sensor (IN3 input, terminals 7-8).

The 3 remaining inputs can be used to monitor the temperature of fluids inside the technical compartment or to connect some voltage-free binary inputs such as flow request or external clock to activate a time scheduling.

The DO1 output (terminals 20-21) is dedicated to control the circulator on the mixing group; the remaining outputs DO2 and DO2, as well as the 0-10V analog output signal, can be used for additional commands.



When using 3 point floating servomotors to control a mixing valve, it is important to properly identify the opening and closing terminal of the servomotor, which make the valve directly open or close. An uncorrect electrical wiring will lead to an uncorrect system behavior.

In order to facilitate commissioning and valve calibration, the EK-HH1-TP controller, after its bus terminals have been powered, when detecting an activation request, runs a complete closing cycle of the valve. If the electrical and mechanical wiring among control unit, servomotor and valve have been properly executed, the valve completely closes the direct connection to the heat generator.

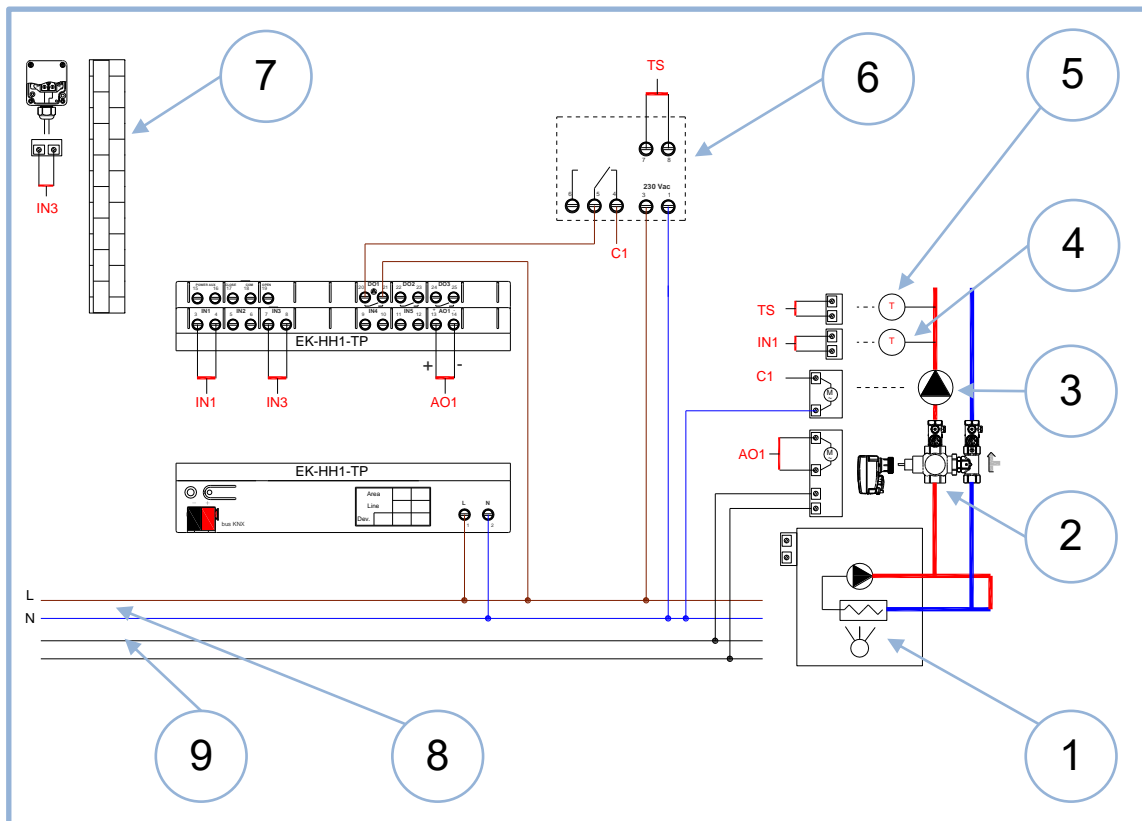

Use of a servomotor with 0-10V control signal: the output (terminals 13-14) must be directly connected to the servomotor's control input, paying attention to the proper signal polarity. The servomotor shown in this example has its own auxiliary power supply at 24Vac. In this application, a climatic compensation is performed by connecting an immersion temperature sensor (IN1 input, terminals 3-4) in a manhole on delivery (after the circulator) and connecting an outside temperature sensor (IN3 input, terminals 7-8).

The 3 remaining inputs can be used to monitor the temperature of fluids inside the technical compartment or to connect some voltage-free binary inputs such as flow request or external clock to activate a time scheduling.

The DO1 output (terminals 20-21) is dedicated to control the circulator on the mixing group; the remaining outputs DO2 and DO2, as well as the 0-10V analog output signal, can be used for additional commands.

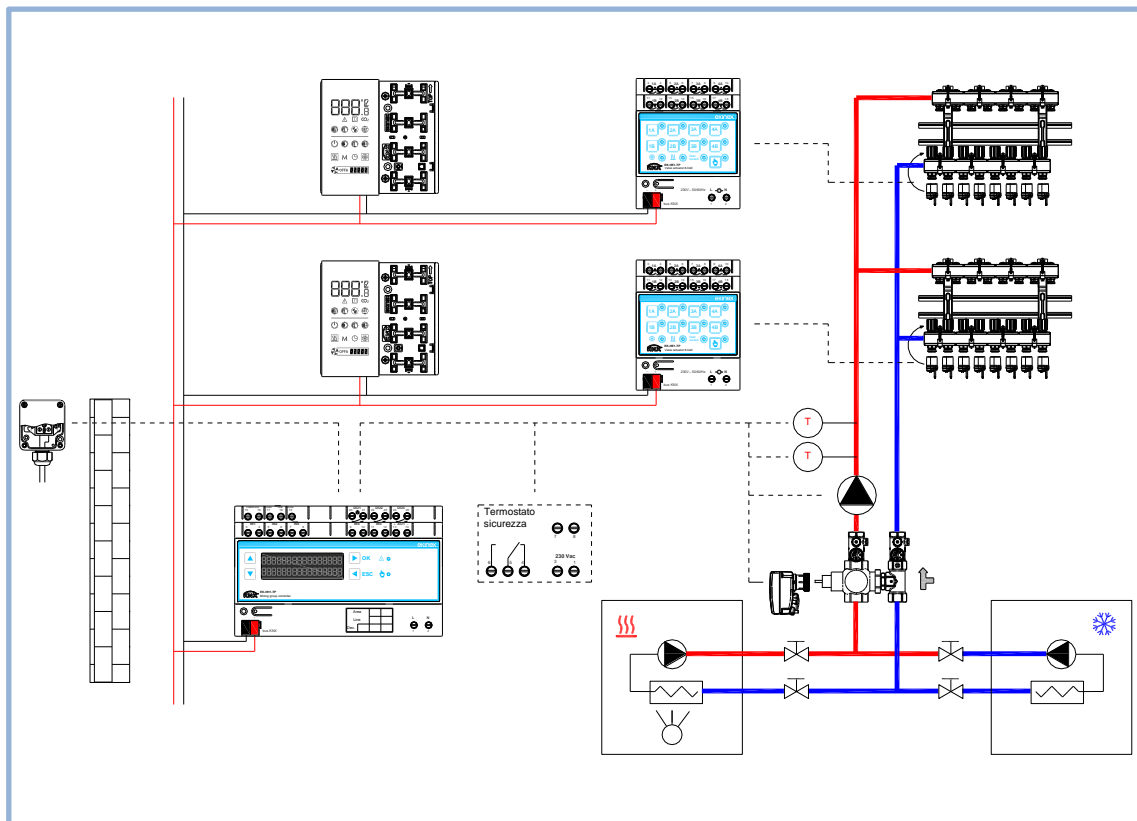

Heating and cooling radiant plant with room thermostats EK-EQ2-TP and relative humidity detection.

In this application, the main control is performed by an EK-HH1-TP device; the room temperature control is carried out by thermostats and the power modules EK-HE1-TP, installed next to the distribution manifolds, act as actuators through the command of electrothermal actuators on the relevant zone circuits.

The EK-HH1-TP controller, via KNX bus, detects the activation requests of the zones. Then it detects and the deviation from the desired internal conditions and evaluates the relative humidity conditions inside the environments to input the refrigerated fluid into the circuits under optimal conditions, thus maximizing efficiency and avoiding surface condensation during cooling mode.

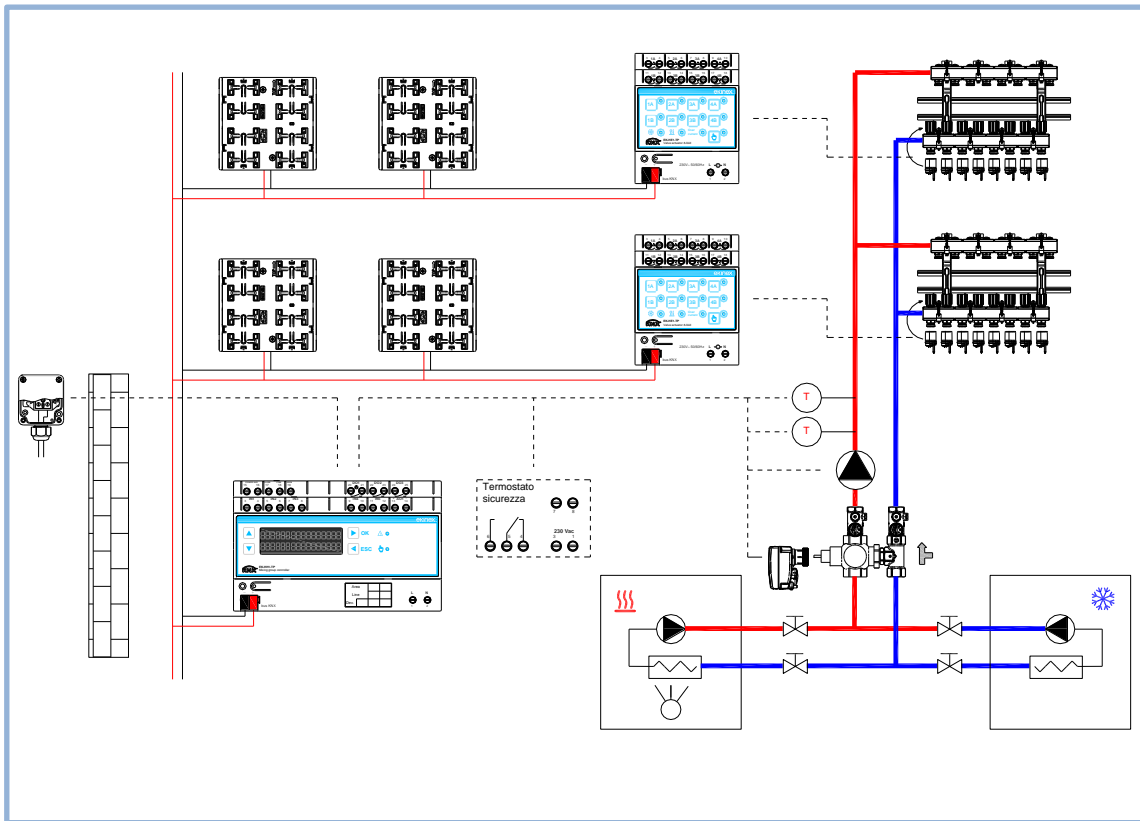

Heating and cooling radiant plant with use of pushbutton commands for room temperature detection.
 In this application, the main control is performed by an EK-HH1-TP device; the pushbutton commands dedicated to lighting (if installed in proper positions) also detect the room temperature; the power modules EK-HE1-TP, installed next to the distribution manifolds, act as actuators through the command of electrothermal actuators on the relevant zone circuits.
 The EK-HH1-TP controller, via KNX bus, detects the activation requests of the zones and the deviation from the desired internal conditions. Anticondensation contact probes can be connected to the controller's inputs in order to cut out the flow or rise the delivery temperature to the circuits, thus avoiding surface condensation during cooling mode.

10 Warnings

- Installation, electrical connection, configuration and commissioning of the device can only be carried out by qualified personnel.
- Opening the housing of the device causes the immediate end of the warranty period.
- ekinex® KNX defective devices must be returned to the manufacturer at the following address:
SBS S.p.A. - Via Circonvallazione s/n, I-28010 Miasino (NO) Italy.

11 Other information

- This application manual is aimed at installers, system integrators and planners
- For further information on the product, please contact the ekinex® technical support at the e-mail address: support@ekinex.com or visit the website www.ekinex.com
- ekinex® is a registered trademark of SBS S.p.A.
- KNX® and ETS® are registered trademarks of KNX Association cvba, Brussels

© SBS S.p.A. 2017. The company reserves the right to make changes to this documentation without notice.