



# KNX S1R-UP KNX S1R-BA2-UP KNX S1R-BA4-UP

## Multifunctional Actuators

### Technical specifications and installation instructions

Item numbers 70511 (KNX S1R-UP), 70512 (KNX S1R-BA2-UP), 70513 (KNX S1R-BA4-UP)



**Elsner Elektronik GmbH** Control and Automation Engineering

Sohlegrund 16  
75395 Ostelsheim  
Germany

Phone +49 (0) 70 33 / 30 945-0 info@elsner-elektronik.de  
Fax +49 (0) 70 33 / 30 945-20 www.elsner-elektronik.de

Technical support: +49 (0) 70 33 / 30 945-250

# 1. Description

**Actuators KNX S1R** with integrated façade control have a multifunctional output which can connect to either a drive with Up/Down control (blinds, awnings, shutters, windows) or two switchable devices (On/Off for light and ventilation). Because the output is designed to be free of potential, other systems can also be controlled, e.g. via the manual switch input on a motor control unit.

Automation can be specified externally or internally. Internally, there are numerous options available for blocking, locking (e.g. master-slave) and priority definitions (e.g. manual-automatic). Scenes can be saved and called up via the bus (scene control with 16 scenes per drive).

The **KNX S1R-B4-UP** and **KNX S1R-BA2-UP** models are equipped with inputs which are used as bus inputs (buttons, alarms, etc.) or for T-NTC temperature sensors. The **KNX S1R-UP** model does not have any analogue/digital inputs.

## Functions:

- **Free of potential multifunctional output for a 230 V drive** (shading, windows) or connection of two **switchable devices** (light, fan)
- Relays switch with low wear near the zero-voltage transition
- **Inputs** for binary contact or temperature sensor (not on KNX S1R-UP)
- **Automatic runtime measurement** of the drives for positioning (incl. fault reporting object)
- **Position feedback** (movement position, also slat position for shutters)
- **Position storage** (movement position) via 1-bit object (storage and call-up e.g. via buttons)
- Parameters for taking drive and mechanics downtimes into account
- Control via **internal or external automation functions**
- Integrated **shade control** with **slat adjustment** for shutters based on the position of the sun
- **Scene control** for movement position with 16 scenes per drive (also slat position for shutters)
- Mutual **locking** of two drives using zero position sensors prevents collisions e.g. of shade and window (master-slave)
- **Blocking objects and alarm reports** have different priorities, so safety functions always take precedence (e.g. wind block)
- Manual or automatic **priority** setting via time or communication object
- **4 temperature switching outputs** in the application program with adjustable threshold values (presetting the parameters or communication object)
- **Brief time limit** (movement command blocked) and **2 movement limits**

Configuration is made using the KNX software ETS. The **product file** can be downloaded from the Elsner Elektronik website on [www.elsner-elektronik.de](http://www.elsner-elektronik.de) in the "Service" menu.

## 1.0.1. Scope of delivery

- Actuator

## 1.1. Technical specification

Housing	Plastic
Colour	White
Assembly	Flush-mounted (in connector socket Ø 60 mm, 60 mm deep)
Protection category	IP 20
Dimensions	approx. 50 x 50 x 54 (W x H x D, mm)
Weight	approx. 100 g
Ambient temperature	Operation -20...+70°C, storage -30...+85°C
Ambient humidity	5...80% RH, non-condensing
Operating voltage	KNX bus voltage
Current at the bus	10 mA
Output	1 x output, free of potential with 2 connections for drive up/down or 2 devices (power supply, PE/N/1/2). Secured by a microfuse T4.0 A. Can withstand a total of max. 4 A (resistive load), switch-on current totally max. 4 A at ≤ 20ms.
Minimum current for runtime measurement	AC effective 200 mA
Inputs	KNX S1R-UP: no inputs KNX S1R-BA2-UP: 2x analogue/digital. KNX S1R-BA4-UP: 4x analogue/digital. max. output length 10 m
Setting range for the T-NTC temperature sensor on the input	-30°C...+80°C
Data output	KNX +/- bus connector terminal
BCU type	Integrated microcontroller
PEI type	0
Group addresses	max. 1024
Assignments	max. 1024
Communication objects	KNX S1R-UP: 147 KNX S1R-BA2-UP: 174 KNX S1R-BA4-UP: 200

The product is compliant with the provisions of EU guidelines.

---

## 2. Installation and start-up

---

### 2.1. Installation notes

---



Installation, testing, operational start-up and troubleshooting should only be performed by an electrician.

---



#### **DANGER!**

#### **Risk to life from live voltage (mains voltage)!**

There are unprotected live components within the device.

- VDE regulations and national regulations are to be followed.
  - Ensure that all lines to be assembled are free of voltage and take precautions against accidental switching on.
  - Do not use the device if it is damaged.
  - Take the device or system out of service and secure it against unintentional use, if it can be assumed, that risk-free operation is no longer guaranteed.
- 

The device is only to be used for its intended purpose. Any improper modification or failure to follow the operating instructions voids any and all warranty and guarantee claims.

After unpacking the device, check it immediately for possible mechanical damage. If it has been damaged in transport, inform the supplier immediately.

The device may only be used as a fixed-site installation; that means only when assembled and after conclusion of all installation and operational start-up tasks and only in the surroundings designated for it.

Elsner Elektronik is not liable for any changes in norms and standards which may occur after publication of these operating instructions.

## 2.2. Installation

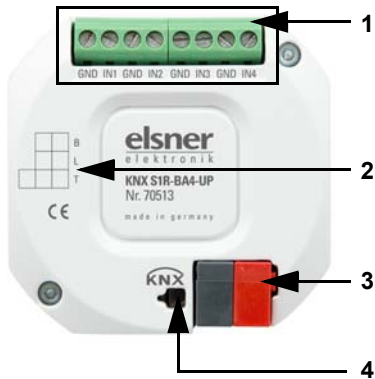

Fig. 1: Bus side

- 1 Analogue/digital inputs connector (not for KNX S1R-UP)
- 2 Label field
- 3 KNX terminal +/-
- 4 Programming LED and programming button (countersunk)

Analogue/digital inputs connector assignment:

KNX S1R-UP: Not assigned!

KNX S1R-B2A-UP: 1: GND | 2: IN1 | 3: GND | 4: IN2

KNX S1R-BA4-UP: 1: GND | 2: IN1 | 3: GND | 4: IN2 | 5: GND | 6: IN3 | 7: GND | 8: IN4

All GND connectors are internally bridged.



Fig. 2: Output side

- 1 Connector for drive/consumers (free of potential)

## 2.3. Connection

The **Actuators KNX S1R** are installed in a flush-mounted socket. The connection is made using a KNX connector on the KNX data bus. In addition, a power supply for the connected drive or consumer is necessary (output free of potential).



**Follow the guidelines and standards for SELV electric circuits while installing and cable laying of the KNX connection and inputs!**



### ATTENTION!

**Relays may be switched on when starting the device for the first time!**

The bistable relays used in this product may switch on in case of shock, e. g. during transportation.

- First apply the bus voltage, as this will switch off the relays. Then switch on the voltage supply of the drive.

The physical address is assigned by the KNX software. There is a button with a control LED for this on the actuator.

### 2.3.1. Connection examples

#### 230V drive at the output:

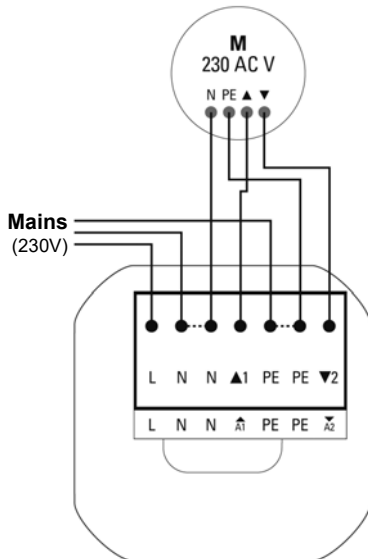

#### Two 230V consumers at the output:

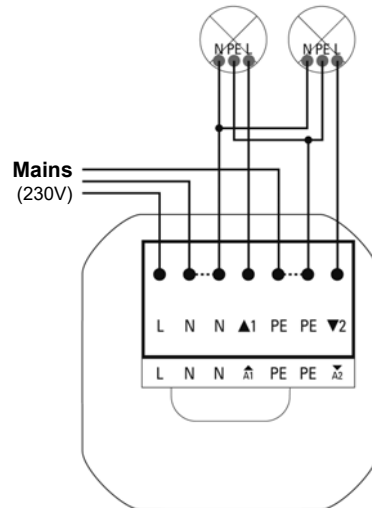

### Control of an external motor control unit via the output:

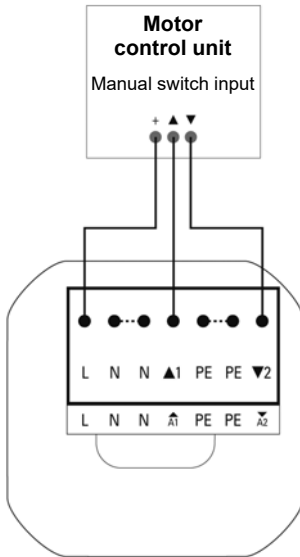

**Note:** The **Actuators KNX S1R** can also be used with direct-current voltage (12 V DC, 24 V DC) due to their potential-free output. The „L“ connector is used as „Com“ in this case. The automatic runtime measurement is not possible with direct-current voltage!

### Inputs:

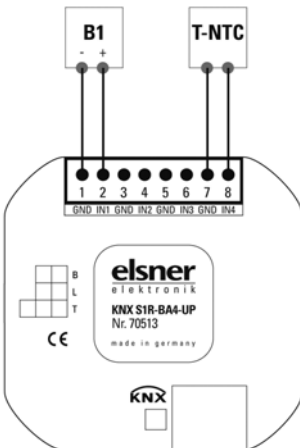

*Example KNX S1R-B4-UP with binary contact on input 1 and T-NTC temperature sensor on input 4.*

*Connection of the temperature sensor is independent of the polarity.*

## **2.4. Instructions for assembly and operational start-up.**

---

Never expose actuators to water (e.g. rain) or dust. This can damage the electronics. You must not exceed a relative air humidity of 80%. Avoid condensation.

After the auxiliary voltage has been applied, the device will enter an initialisation phase lasting a few seconds. During this phase no information can be received or sent via the bus.

For KNX devices with safety functions (e.g. wind or rain blocks), it is important to set up periodical monitoring of the safety objects. The optimal ratio is 1:3 (example: if the weather station sends a value every 5 minutes, the actuator must be configured for a monitoring period of 15 minutes).

## **3. Addressing of the device at the bus**

---

The device is supplied with the bus address 15.15.250. You can program another address into the ETS by overwriting the 15.15.250 address or by teaching via the programming key.



