

# Cala KNX MultiTouch T Light/Sunblind

## Cala KNX MultiTouch T Light/Scenes

### Cala KNX MultiTouch T Light

#### Button for light, drive, scenes and temperature control

#### Technical specifications and installation instructions

**Cala KNX MultiTouch T Light/Sunblind:**  
Item numbers  
70890 (white),  
70892 (black)

**Cala KNX MultiTouch T Light/Scenes:**  
Item numbers  
70960 (white),  
70962 (black)

**Cala KNX MultiTouch T Light:**  
Item numbers  
70950 (white),  
70952 (black)



## 1. Description

The **Cala KNX MultiTouch T push button** has touch-sensitive buttons with which functions can be called up in the KNX building bus system. The glass surface is printed with areas for setting the light and temperature. Coloured LEDs (one white LED in the light symbol, one red and one blue LED in the thermometer symbol and three white LEDs each for level indication) are integrated in these areas and their behaviour can be adjusted. With **Cala KNX MultiTouch T Light/Sunblind**, an area for moving blinds/sunshades (up/down) is added, and with **Cala KNX MultiTouch T Light/Scenes**, an area for calling up scenes (3 scenes).

A temperature sensor is integrated into **Cala KNX MultiTouch T**. An external temperature reading can be received via the bus and processed with its own data to create a total temperature (mixed value).

The **Cala KNX MultiTouch T** has a PI controller for heating and cooling. The set-point temperature can be changed using the "+" and "-" touch buttons.

Communication objects can be linked via AND and OR logic gates.

The device is supplemented with a frame of the switch series used in the building, and thus fits seamlessly into the interior fittings.

#### Functions:

- **Operating zone for light** with 3 areas (switching and dimming)
- **Operating zone for temperature control** with 3 areas (warmer, cooler, changeover heating/cooling)
- A total of 9 areas, all of which can be assigned either to the intended bus functions or to other individual bus functions (switches, changeover switches, dimmers, blinds, awnings, shutters, windows, 8- or 16-bit encoders, scene call/saving)
- **LEDs** can be set. All LEDs Off, all LEDs On, active LEDs Always On, all LEDs On for specific time after button pressed, active LEDs On for specific time after button pressed. Settable, as to whether LED flashes at block object value = 1. LED brightness can be pre-set for day and night
- **Area function** when touching two or more push buttons. Can be configured as switch, selector switch, as 8 or 16 bit encoder or for scenario recall
- **Scene control**. 3 scene channels with 5 objects each
- **Temperature** measurements. **Mixed value** from own measured value and external values (proportion can be set by percentage), output of minimum and maximum values
- **PI-controller for heating** (one or two-level) and **cooling** (one or two-level) according to temperature. Regulation according to separate setpoints or basic setpoint temperature
- **4 AND and 4 OR logic gates** each with 4 inputs. All switching events as well as 8 logic inputs (in the form of communications objects) can be used as inputs for the logic gates. The output from each gate can be configured optionally as 1-bit or 2 x 8-bit

#### Additional functions Cala KNX MultiTouch T Light/Sunblind:

- **Operating zone for blinds**, awnings, shutters or windows with 3 areas (up/down with short/long distinction, driving position)

#### Additional functions Cala KNX MultiTouch T Light/Scenes:

- **Operating zone for scene call and saving** with 3 areas for scenes

Configuration is made using the KNX software ETS 5. The **product file** can be downloaded from the ETS online catalogue and the Elsner Elektronik website on [www.elsner-elektronik.de](http://www.elsner-elektronik.de) in the "Service" menu.

### 1.0.1. Area function

If the area function in ETS has been activated, another function is available alongside the regular key functions. This is triggered by touching multiple keys, e.g. if you touch the sensor with the palm of your hand.

#### Using the area function

If a key is pressed and another (different) key is touched within 0.2 seconds, the action set in the ETS is performed for the area operation (See Fig. 1 a) and b)). The keys are then blocked for 0.5 seconds.

#### Using the normal key function

If a key is pressed and no other key is touched within 0.2 seconds, the normal key function is enabled/provided for 5 seconds (See Fig. 1 c) and d)). This is extended for 5 seconds with each push of the button.

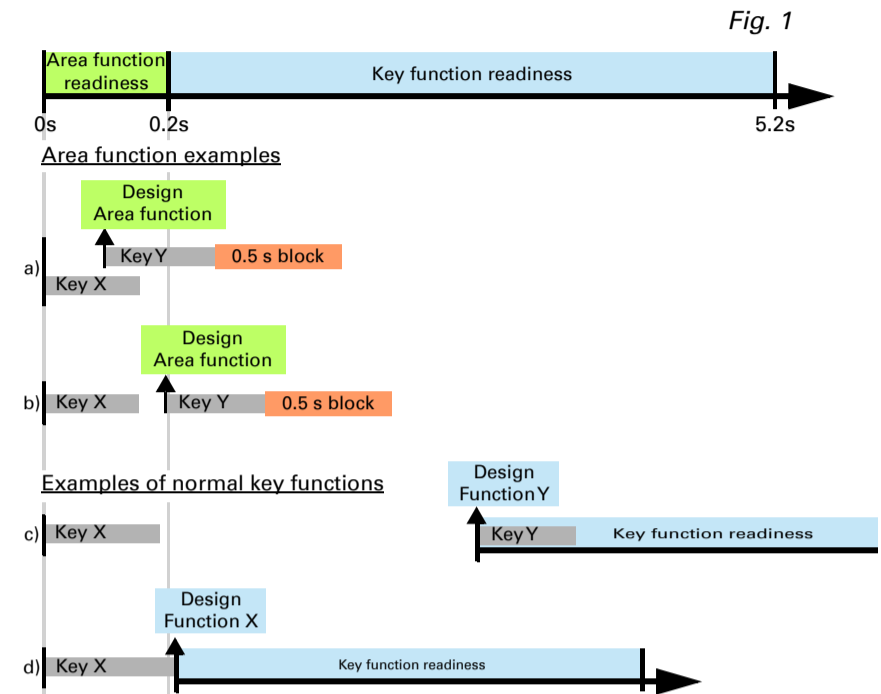

If the area function in the ETS is disabled, the keys can be used normally at any time.

### 1.0.2. Scope of delivery

- Push button in casing
- Base plate

Additionally required (not included in the deliverables):

- Junction box Ø 60 mm, 42 mm deep
- Frame (for insert 55 x 55 mm), compatible to the switch scheme used in the building

### 1.1. Technical data

Casing	Genuine glass, plastic
Colours	<ul style="list-style-type: none"> <li>• similar to RAL 9010 pure white</li> <li>• similar to RAL 9005 deep black</li> </ul>
Assembly	Flush-mounted (wall installation in junction box Ø 60 mm, 42 mm deep or cavity wall socket for burr hole Ø 68 mm)
Degree of protection	IP 20
Dimensions	Housing approx. 55 x 55 (W x H, mm), Installation depth approx. 10 mm, Base plate approx. 71 x 71 (W x H, mm)
Total weight	approx. 50 g
Ambient temperature	Operation and storage -25...+85°C
Ambient humidity	max. 95% RH, avoid condensation
Operating voltage	KNX bus voltage
Bus current	max. 19 mA
Data output	KNX +/- Bus plug-in terminal
Group addresses	max. 205
Assignments	max. 205
Communication objects	Cala KNX MultiTouch T Light/Sunblind: 199 Cala KNX MultiTouch T Light/Scenes: 198 Cala KNX MultiTouch T Light: 198
Temperature measurement range	-25...+85°C
Temperature resolution	0.1°C

The product is compliant with the provisions of EU Directives.

#### 1.1.1. Accuracy of the measurement

Measurement variations from permanent sources of interference (see chapter *Installation position*) can be corrected in the ETS in order to ensure the specified accuracy of the sensor (offset).

When **measuring temperature**, the self-heating of the device is considered by the electronics. The heating is compensated by the software.

## 2. Installation and commissioning

### 2.1. Installation notes



Installation, testing, operational start-up and troubleshooting should only be performed by an electrician.

**CAUTION!**  
**Live voltage!**

There are unprotected live components inside the device.

- National legal regulations are to be followed.
- Ensure that all lines to be assembled are free of voltage and take precautions against accidental switching on.
- Do not use the device if it is damaged.
- Take the device or system out of service and secure it against unintentional use, if it can be assumed, that risk-free operation is no longer guaranteed.

The device is only to be used for the intended purpose described in this manual. Any improper modification or failure to follow the operating instructions voids any and all warranty and guarantee claims.

After unpacking the device, check it immediately for possible mechanical damage. If it has been damaged in transport, inform the supplier immediately.

The device may only be used as a fixed-site installation; that means only when assembled and after conclusion of all installation and operational start-up tasks and only in the surroundings designated for it.

Elsner Elektronik is not liable for any changes in norms and standards which may occur after publication of these operating instructions.

## 2.2. Installation location

The **Cala KNX MultiTouch T push button** is designed for wall installation in a connector socket (Ø 60 mm, 42 mm deep).

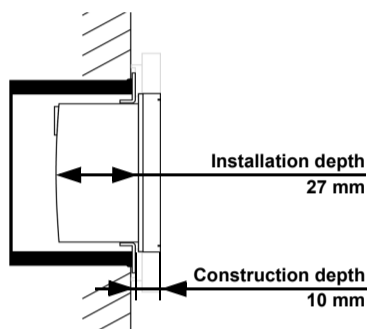

Fig. 2: Cross-section drawing.  
The **Cala KNX MultiTouch T push button** fits in a standard connector socket (Ø 60 mm, depth 42 mm).  
The frame is not included in the delivery!

**May be installed and operated in dry interior rooms only.**  
**Avoid condensation.**

When selecting an installation location, please ensure that the measurement results are affected as little as possible by external influences. Possible sources of interference include:

- Direct sunlight
- Drafts from windows and doors
- Draft from ducts which lead from other rooms or from the outside to the junction box in which the sensor is mounted
- Warming or cooling of the building structure on which the sensor is mounted, e.g. due to sunlight, heating or cold water pipes
- Connection lines and ducts which lead from warmer or colder areas to the sensor

Measurement variations from permanent sources of interference can be corrected in the ETS in order to ensure the specified accuracy of the sensor (offset).

## 2.3. Device structure

### 2.3.1. Casing

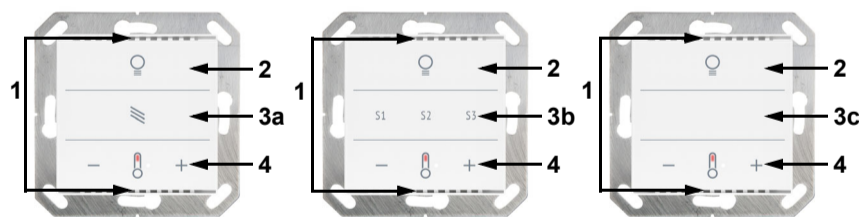

Fig. 3 Front  
1 Ventilation slits (top and bottom)  
2 "Light" area with 3 touch surfaces  
3a "Sun protection/drive" area with 3 touch surfaces  
3b "Scenes" area with 3 touch surfaces  
3c 3 configurable touch surfaces  
4 "Temperature" area with 3 touch surfaces

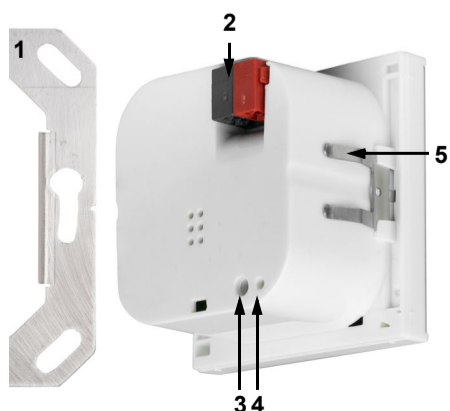

Fig. 4 Back  
1 Base frame  
2 KNX terminal BUS +/-  
3 Programming LED (recessed) for teaching the device  
4 Programming LED (recessed)  
5 Catches

## 2.4. Installation of the sensor

First install the windproof socket with feed line. Seal the inlet tubes as well, in order to prevent draughts.

Then screw the base plate to the socket and place the switch program frame. Connect the bus cable +/- to the plug (black-red).

Insert the device firmly onto the metal frame using the catches so that the device and the housing are fixed together.

## 3. Notes on mounting and commissioning

Never expose the device to water (e.g. rain) or dust. This can damage the electronics. You must not exceed a relative humidity of 95%. Avoid condensation.

After the bus voltage has been applied, the device will enter an initialisation phase lasting a few seconds. During this phase no information can be received or sent via the bus.

### 3.1. Addressing of the device at the bus

The individual address is assigned via the ETS. A button and a control LED are located on the unit for this purpose (Fig. 4, No. 3+4).

The equipment is delivered with the bus address 15.15.255. Another address can be programmed using the ETS.

When programming mode is active, the programming LED lights up and in addition the 6 white LEDs for temperature level display and all other active LEDs flash.

## 4. Maintenance

Ventilation slits must not be dirty or covered. As a rule, it is sufficient to wipe the device with a soft, dry cloth as required.

## 5. Disposal

After use, the device must be disposed of or recycled in accordance with the legal regulations. Do not dispose of it with the household waste!