

Presence detector Comfort Mini

Order No. : 2225 00

Presence detector Standard Mini

Order No. : 2220 00

Operating instructions**1 Safety instructions**

Electrical equipment may only be installed and fitted by electrically skilled persons.

Serious injuries, fire or property damage possible. Please read and follow manual fully.

Do not press on the sensor window. Device can be damaged.

The device is not suitable for use as a burglar alarm or other alarm.

Caution. Damage to sensors may result due to high thermal radiation. Avoid direct sunlight penetration in the sensor window.

These instructions are an integral part of the product, and must remain with the end customer.

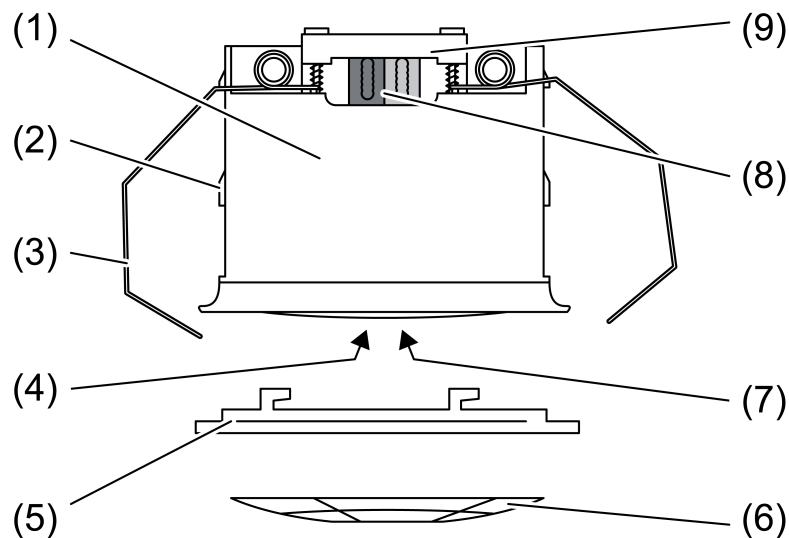
2 Device components

Figure 1: Device components

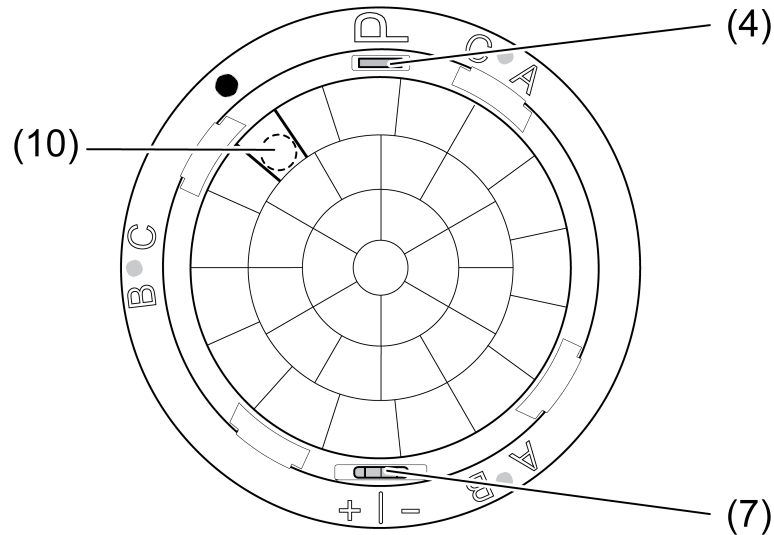


Figure 2: Device components

- (1) Motion detector
- (2) Guide for clamping springs
- (3) Spring clamp
- (4) Programming button, red
- (5) Design ring
- (6) Cover
- (7) Sensitivity switch, blue
- (8) Bus connection
- (9) Cable fixation
- (10) Brightness sensor

3 Function

System information

This device is a product of the KNX system and complies with the KNX directives. Detailed technical knowledge obtained in KNX training courses is a prerequisite to proper understanding.

The function of this device depends upon the software. Detailed information on loadable software and attainable functionality as well as the software itself can be obtained from the manufacturer's product database. Planning, installation and commissioning of the device are carried out with the aid of KNX-certified software. The latest versions of product database and the technical descriptions are available on our website.

Intended use

- Requirement-oriented control of lighting, room thermostats and other electrical consumers in interior rooms
- Clamp mounting in suspended ceilings
- Ceiling mounting on fixed ceilings in flush-mounted box according to DIN 49073 or surface-mounted housing (see accessories)

Product characteristics

- Integrated bus coupling unit
- 3 PIR sensors
- Detection field 360°
- Integrated brightness sensor
- Deployed as presence detector, motion detector, or for alert operation
- Output functions: Switching, staircase function, switching with forced position, value transmitter, light scene extension, operating mode setting for room temperature controller

- Detection area extendible by parallel switching of several devices as main unit or extension unit
- Adjuster for manual adjustment of sensitivity
- Status LED: Flashes during motion detection; depending on programming in normal operation or only during the walking test mode

Additional characteristics of "Comfort" version:

- Manual operation with IR remote control possible (accessories)
- 5 function blocks for motion or presence detection each with 2 outputs
- Function blocks switchable, e.g. for day/night operation
- PIR sensors can be evaluated separately
- Brightness sensor function with 3 limiting values
- Light control with max. of 3 channels, setpoint shift in operation, separate configuration of dimming-up, control and dimming-down phase
- Light control can be combined with presence detector function

Presence detector function:

- Detection of the smallest motions e.g. at a workplace for detecting the presence of persons
- Switch on: Motion detection and brightness threshold not reached
- Switch off: No motion in the detection field and run-on-time elapsed or brightness threshold exceeded

Motion detector function:

- Detection of motions for passageway security in buildings
 - Switch on: Motion detection and brightness threshold not reached
 - Switch off: No motion in the detection field and run-on-time elapsed
- i** After reacting and switching on, the motion detection works independently of the brightness.

Alert operation:

- Brightness-independent detection of motions in the detection field
- Switch on: After detection of an adjustable number of motions within the set monitoring period
- Switch off: No persons in the detection field and run-on-time elapsed

4 Operation











Only for "Comfort" version:

Function buttons IR remote control

Button	Function
On ☀ +	Detection of a motion is sent for function block 1. The automatic mode is exited.
Off ☀ -	End of a motion is sent for function block 1. The automatic mode is exited.
Auto ☀	The automatic mode is activated again for function block 1. The ON state is first exited after a new motion detection.

Adjustable buttons IR remote control

Button	Function
Sens +	Increasing sensitivity
Sens -	Reducing sensitivity
Sens =	Resetting sensitivity to presetting
☾	Function block 1: Brightness threshold 10 lx
☀	Function block 1: Brightness threshold 50 lx




	Function block 1: Brightness threshold 150 lx
	Function block 1: Brightness independent operation
Teach 	Function block 1: Set current brightness as brightness threshold
10 sec  , 30 sec  , 2 min  , 5 min  , 30 min 	Function block 1: Extend minimum run-on-time (10 seconds) by the selected value
Start  , Stop 	Function block 1: Extend minimum run-on-time (10 seconds) individually

Set-up buttons of IR remote control

Button	Function
Test	Walking test – Check detection field
Reset	Reset sensitivity, brightness threshold and run-on-time to presetting. Press for at least 3 seconds

Operation with IR remote control

If enabled, function block 1 can be operated manually by remote control. In manual operation, brightness and motion detection for function block 1 are switched off until automatic mode is reset.


- Switch on, e.g. light: Press **On** + button.
- Switch off, e.g. light: Press **Off** - button.
- Set automatic mode: Press **Auto**  button.

Manually changing settings with IR remote control






If enabled, individual settings for function block 1 can be changed during operation using a remote control.

Sensitivity:


- Increase sensitivity: Press **Sens+** button.
- Decrease sensitivity: Press **Sens-** button.
- Recall set sensitivity again: Press **Sens=** button.

 The manual adjustment of sensitivity by the sensitivity switch (7) is overwritten by the IR-remote control and vice versa.

Brightness threshold:

- Change brightness threshold: Depending on requirement, press  button,  button,  button or  button.
- Set current brightness as brightness threshold: Press **Teach**  button.

Run-on-time: The preset run-on-time of 10 seconds can be extended individually.

- Extend run-on-time: Depending on requirement, press **10 sec**  button, **30 sec**  button, **2 min**  button, **5 min**  button or **30 min**  button. Other values can be set with the **Start** /**Stop**  buttons.

5 Information for electrically skilled persons

5.1 Fitting and electrical connection

Motion detection

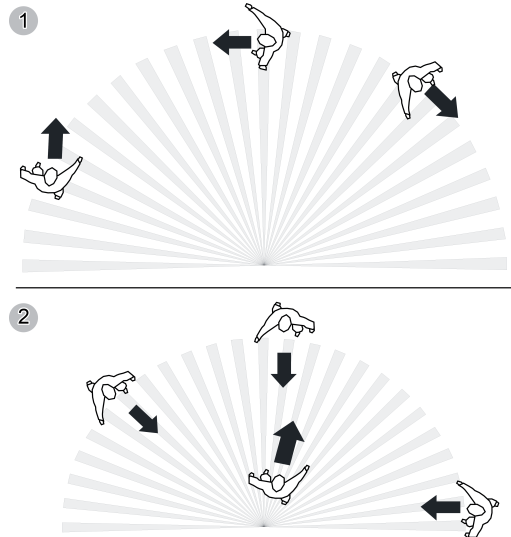


Figure 3: Tangential and radial direction of motion

The device has a detection area of 360°. The diameter of the detection area depends on the installation height and the direction of motions of persons in the detection area (Figure 4).

The detection area becomes larger the greater the installation height, while the detection density and sensitivity are reduced at the same time.

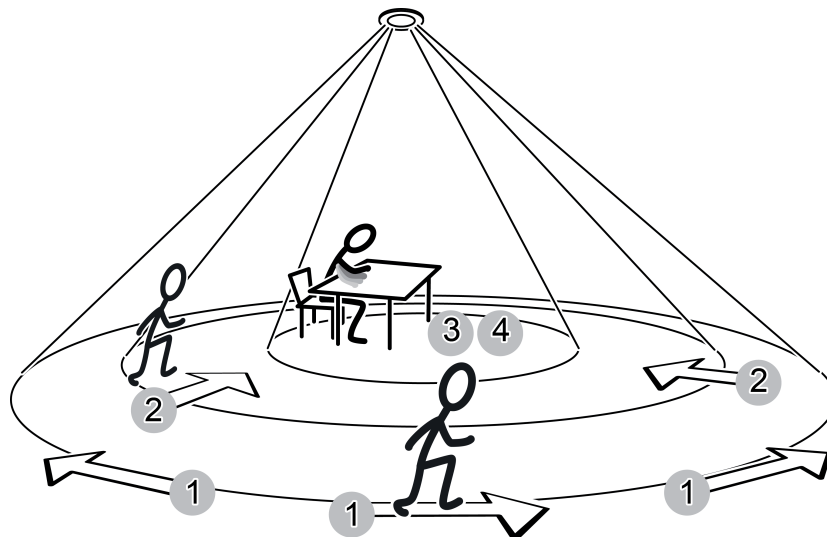


Figure 4: Detection range depending on the direction of movement

Diameter of detection area for direction of movement

Installation height	1:	2:	3:	4:
2.20 m	8.8 m	6.6 m	4.4 m	2.9 m
2.50 m	10 m	7.5 m	5 m	3.3 m

3.00 m	12 m	9 m	6 m	4 m
3.50 m	13 m	9.5 m	7 m	4.7 m
4.00 m	14 m	10 m	7.5 m*)	- *)
5.00 m	17 m	11 m	8 m*)	- *)

- 1: Range for tangential movement on the ground
 - 2: Range for radial movement on the ground
 - 3: Range for typical movements at desks, e.g. torso movement
 - 4: Range of fine detection at desks, e.g. mouse movements
- *) When used as a presence detector: Installation height should not be more than 3.5 m, otherwise fine detection is not possible.

The device has three independent sensors for motion detection. The arrangement of the sensor areas A, B and C is clearly evident under the decor ring .

- i** If the sensor areas A, B, C are evaluated separately, the project design must take the alignment of the device into account (see chapter Aligning the device).

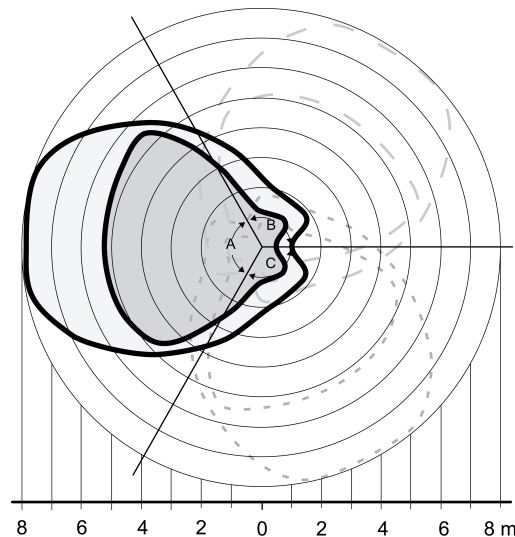


Figure 5: Detection field areas A, B and C, installation height 3.00 m

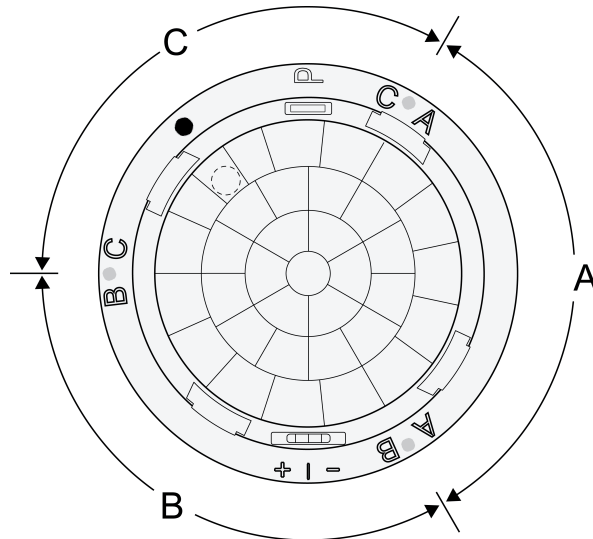


Figure 6: Arrangement of the areas A, B and C

Brightness detection

The brightness sensor (8) is attached on the side and thus enables an asymmetric measuring surface. In this way, for example, it is possible to include several work places in the measurement without any laterally entering light distorting the measurement.

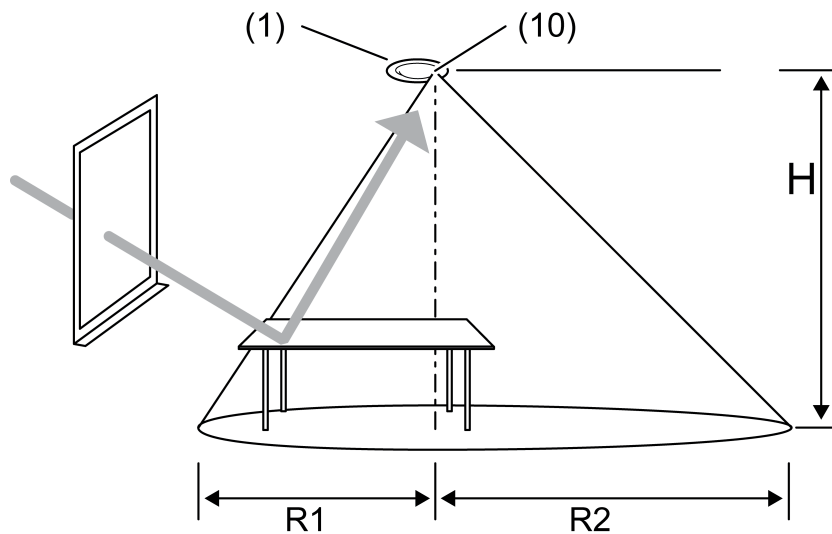


Figure 7

Installation height H	R1	R2
2.20 m	1.5 m	2.3 m
2.50 m	1.8 m	2.6 m
3.00 m	2.0 m	3.0 m
3.50 m	2.5 m	3.6 m
4.00 m	2.8 m	4.2 m
5.00 m	3.5 m	5.2 m

Light falling directly onto the sensor or reflected by shiny surfaces influences the brightness detection.

Selecting the installation location

When used as a presence detector, the device is installed on the ceiling and monitors the surface below it. When used as a motion detector, the device is installed e.g. in the hallway on the ceiling.

- Select a vibration-free installation location. Vibrations can lead to unwanted switching.
 - Avoid interference sources in the detection area. Interference sources, e.g. heaters, ventilation, air conditioners, and cooling light bulbs can lead to unwanted detections.
- i** If necessary, the detection area can be limited using the push-on cover in order to minimize the influence of interference sources.

Aligning the device

- When mounting, align the device so that the brightness sensor (10) is not facing the window (Figure 7).
- i** Already pay attention to correct alignment when mounting the appliance box and supporting frame.

Connecting and fitting the device in the suspended ceiling

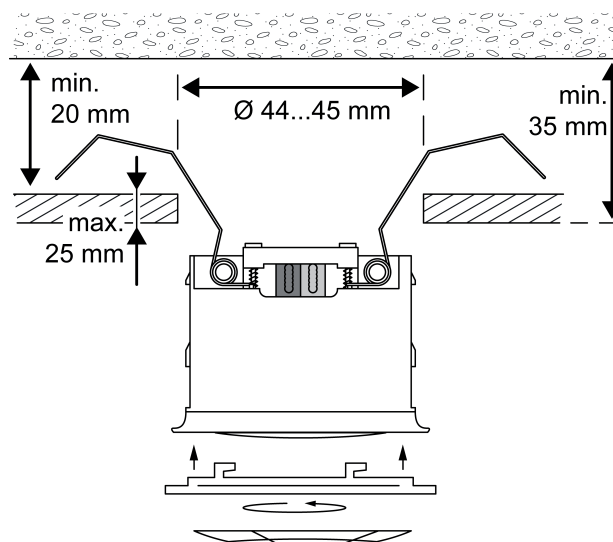


Figure 8

The environment in the suspended ceiling must be dry.

Max. thickness of the suspended ceiling approx. 25 mm. Installation depth min. 35 mm. Distance between concrete ceiling and suspended ceiling min. 20 mm.

Ceiling cut-out 44...45 mm.

- Connect bus line.
- Clamp bus line with cable fixation (9).
- Bend back the spring clamps (3) and push the presence detector (1) into the suspended ceiling.
- Attach the large design ring (5) and rotate it in clockwise direction.
- If required: Cut out the cover (6) and clip it into the design ring (5).

Mounting clamping springs for box mounting

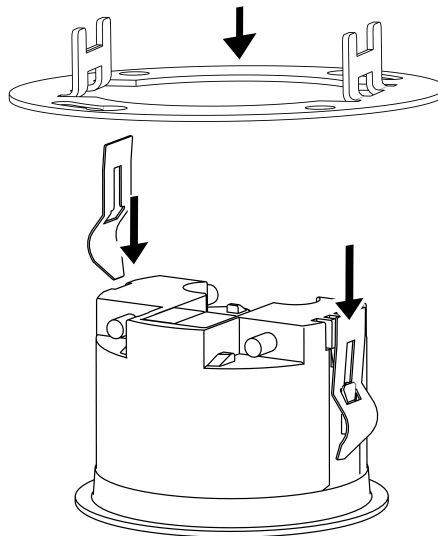


Figure 9

For mounting in flush-mounted box or surface-mounted housing.

- Remove spring clamp (3).
- Push clamping springs (13) in the right orientation on the guides (2) from behind until they snap into place (Figure 9).

Connecting and fitting the device in a flush-mounted box

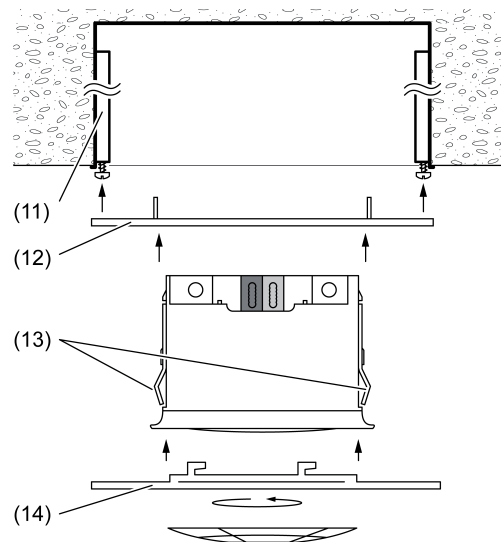


Figure 10

Flush-mounted box (11) is mounted on the ceiling at the designated installation location.

Spring clamps (3) are removed and clamping springs (13) are mounted.

- Mount supporting frame (12) on the flush-mounted boxes (11).
- Connect bus line with connecting terminal.
- Snap the device into the supporting frame (12).
- Attach the large design ring (14) and rotate it in clockwise direction.
- If required: Cut out the cover (6) and clip it into the design ring (14).

Fitting and connecting device in a surface-mounted housing

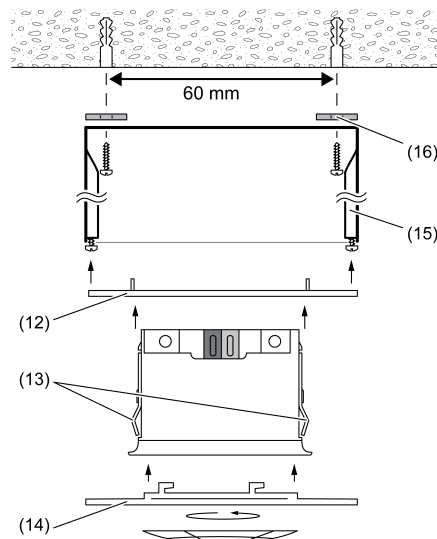


Figure 11

Using a surface-mounted housing (15) (see accessories).

In a humid environment and for IP44 mounting: Provide screw holes of the surface-mounted housing with the supplied seals (16).

Seal the cable entry with the supplied rubber grommet. Cut the rubber grommet appropriately for the bus line. Route the bus line into the surface-mounted housing.

- Mount the surface-mounted housing (15) on the room ceiling at the designated installation location. Hole spacing 60 mm.
- Mount the supporting frame (12) on the surface-mounted housing (15).
- Connect bus line with connecting terminal.
- Snap the device into the supporting frame (12).
- Attach the large design ring (14) and rotate it in clockwise direction.
- If required: Cut out the cover (5) and clip it into the design ring (14).

5.2 Commissioning

Load the address and the application software

- When mounted, remove the design ring.
- Switch on the bus voltage.
- Press the red programming button (4).
The programming LED in the sensor window lights up.
- Assign physical address.
The programming LED goes out.
- Label device on the side with physical address.
- Load the application software into the device.

Testing the detection area

In the case of presence detectors connected in parallel, check the detection areas individually one after the other.


The presence detector is mounted and connected. The physical address and application software are loaded.

- Activate walking test:
Activate parameter "walking test after download" and download application software.

The presence detector operates independently of the brightness. All sensors are active according to their programmed sensitivity.

- Pace off the detection area, paying attention to reliable detection and interference sources. Any motions detected are displayed by the blue status LED in the sensor window.
- Limit detection area if necessary using the push-on cover. Adjust sensitivity with blue sensitivity switch (7) or IR remote control, or change the programming.
- Deactivate parameter "walking test after download" and download application software.

Only for "Comfort" version:

-  If enabled, the walking test function can be activated with the button **Test** of the IR remote control.

6 Appendix

6.1 Technical data

KNX medium	TP
Commissioning mode	S-mode
Rated voltage KNX	DC 21 ... 32 V SELV
Current consumption KNX	max. 10 mA
Connection, Bus	Connection terminal
Protection class	III
Ambient temperature	-25 ... +55 °C
Storage/transport temperature	-25 ... +70 °C
Relative humidity	10 ... 100 % (No moisture condensation)
Degree of protection	IP 44
Dimensions	
Ceiling cut-out Ø×D	44 × 35 mm
Dimensions Ø×H	53.5 × 38 mm (with design ring)
Motion detection	
Detection angle	360 °
Range	Ø approx. 12 m (Installation height 3 m)
Brightness sensor	
Measuring range	10 ... 2000 lx
Accuracy (≤ 80 lx)	± 10 lx
Accuracy (> 80 lx)	± 5%

6.2 Troubleshooting

Light does not switch on despite motion detection and low lighting

Cause 1: Wrong function block active.

Change function block switch-over.

Cause 2: Brightness threshold set is too low.

Increase the brightness threshold with the remote control or parameter setting.

Light switches on despite sufficient ambient lighting

Cause 1: Signal function is active and the device therefore operates independently of the brightness.

Check programming.

Cause 2: Device operates independently of the brightness.

Adjust the brightness threshold with the remote control.

Adjust parameter setting for brightness threshold.

Light switches off briefly and then on again immediately

Cause 1: Light bulbs in the detection area.

Set the configuration barrier parameter so that cooling light bulbs are not detected.

Cause 2: The brightness threshold set is not reached after switching off. Device switches on again immediately during motion detection.

Increase brightness threshold.

Light switches off early despite motion detection and low lighting

Cause 1: The set time is too short.

Increase the time with the remote control or parameter setting.

Cause 2: Detection problem, the surface to be monitored is not in the detection area, or furniture or pillars are in the way.

Check detection field, extend presence detector extension if necessary.


Device responds even without any motion in the detection field

Cause: Interference sources in the detection area or device are set too sensitively.

Limit detection area, remove interference sources.

Adjust sensitivity by one level with blue sensitivity switch (7) or with remote control.

Reduce sensitivity in parameter setting.

 The sensitivity should be reduced by 1 to 2 levels in small spaces.

Light does not switch off despite sufficient ambient lighting

Cause 1: Device is set as motion detector and therefore does not evaluate the ambient lighting after reacting.

Check programming. Set and program device as presence detector.

Cause 2: Brightness threshold set is too high.

Decrease the brightness threshold with the remote control or parameter setting.

Light does not switch on or switches on too late despite motion in the detection field

Cause 1: Device is set for alert operation and does not evaluate the first motion impulse detected.

Check programming. Set and program device as motion detector.

Cause 2: Evaluation delay is activated so that anyone briefly entering the detection area, for example, is not evaluated.

Correct the programming, shorten or deactivate evaluation delay.

6.3 Accessories

Mounting kit for flush-mounted installation
 Mounting kit for surface-mounted installation
 IR remote control for KNX presence detector

Order No. 2241 00
 Order No. 2242 00
 Order No. 2115 00

6.4 Warranty

The warranty is provided in accordance with statutory requirements via the specialist trade.

Please submit or send faulty devices postage paid together with an error description to your responsible salesperson (specialist trade/installation company/electrical specialist trade). They will forward the devices to the Gira Service Center.

Gira
Giersiepen GmbH & Co. KG
Elektro-Installations-
Systeme

Industriegebiet Mermbach
Dahlienstraße
42477 Radevormwald

Postfach 12 20
42461 Radevormwald

Deutschland

Tel +49(0)21 95 - 602-0
Fax +49(0)21 95 - 602-191

www.gira.de
info@gira.de