

EZ382A-FW

kWh-meter 5(105)A 382BC
kWh-Meter 5(65)A 382DE(382A-FW)

Measurement in 4 quadrants

Positive active
Negative active
Positive reactive
Negative reactive

Measurement in up to 8 tariffs Voltage quality measurement

Safe data logging of consumption
Safe data logging of events

Immune to magnetic influence
Tamper detection
OBIS identification codes
Real Time Clock (RTC)

Application

Kamstrup 382 is a direct connected electricity meter for registration of electric energy. The meter is full electronic without movable parts. Thus, shock and impact during transportation and mounting do not affect energy registration.

Furthermore, measurements are correct, no matter the physical mounting direction.

The shunt measuring principle gives good linearity and a considerable dynamic range. The shunt measuring principle is immune against magnetism and DC currents. The easily readable display scrolls automatically between readings, or readings can be changed manually by the consumer activating a push button. The required display readings as well as their order are configurable. In addition to being read from the display data can be collected via the optical output or from the module area by means of a suitable communication module. The unique module area permits external changing of tariffs, pulse input and output, and configuration as well as connection of AMR and AMM modules.

From the factory the meter can be configured to measure both imported and exported energy. As it is constructed with three independent and galvanically separated measuring systems, the meter makes accurate measurements whether it measures on 1, 2, or 3 systems. The energy registration is saved in the integral datalogger, which ensures good data history with its depth of 36.

The meter construction is made so that the measuring

accuracy will not be influenced by magnetism.

The modular construction makes it possible to supply the meter fitted with a real time clock (RTC) with battery backup for tariff control and time stamping of data and events.

The tariff control can change between max. 8 tariffs.

The internal clock (RTC), on the basis of pre-programmed timetables, can change the tariffs. Summer time/ standard time and holidays can also effect the tariff shifts.

The meter is configurable and can be supplied from the factory with required functions. A minimum of handling during installation is thus secured. Furthermore, the meter can be configured to verification mode among other things, which improves the resolutions of the energy indications, thereby reducing the duration of test and verification.



Type approved according to:
Active positive energy

EN 50470-1 (MID)

EN 50470-3 (MID)

Active negative energy and reactive energy

IEC 62052-11

IEC 62053-21

IEC 62053-23



Kamstrup

Functions

Display

The display is a liquid crystal display that makes it possible to read out the meter's registers. Which registers depend on the configuration.

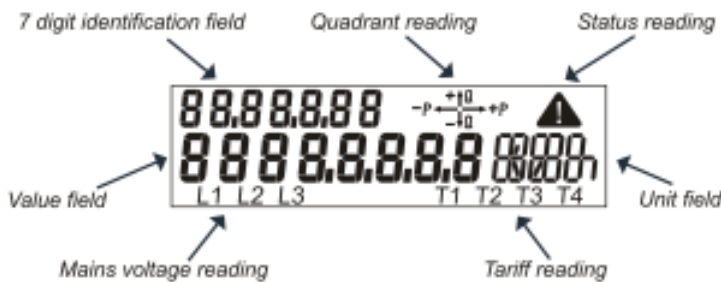
The display configuration is constructed as 3 independent display lists. One for automatic shift function, one for manual shift function and one for battery supplied shift function. The display is constructed of segments as shown on the figure.



Value field

This field is used for displaying register values.

7 digit identification field

OBIS code identification of the value in the value field.

Quadrant reading

The total load is indicated.

Status reading

Indication of critical internal errors.

Unit field

This field is used for displaying the units of registers in the value field.

Tariff reading

Displays the active tariff, if tariffs is chosen.

Mains voltage reading

Indicates whether mains is connected.

The automatic shift function (scroll) changes between the selected readings in the required order every 10 sec. Historical data cannot be selected in the automatic shift function. Up to 16 readings can be selected.

The manual shift function through activation of the push button. The shift is effected when you release the push button. The order is optional, however it is not possible to opt out the legal readings. Up to 40 readings can be selected.

If the meter is configured with battery backup unit a battery-operated shift function, which makes it possible to read the display without the meter being mains supplied, can be selected. Activating the push button changes the reading. Up to 8 readings can be selected.

The meter automatically returns from manual shift function to automatic scroll function two min. after the last activation of the push button.

Calculation

The meter has one shunt per measuring system and resistance division for voltage measurement.

Like voltage drop, energy consumption is calculated as an

expression of the current compared to the phase voltage and time.

The energy registration per measuring system is communicated to the meter's legal processor via the meter's internal bus system.

After correction the energies are summed in the main energy register.

Permanent memory

Measured and calculated data is safely stored in the memory (EEPROM). Data is stored by every change in energy register values.

Furthermore the below mentioned values are stored at the end of a debiting period.

Active energy A+
Active energy AReactive
energy R+
Reactive energy RActive
energy A+ Tariff (T1-T4)
Reactive energy R+ Tariff (T1-T4)
Peak power P+max Tariff 1
Peak power P+max Tariff 1 Hour
Peak power P+max Tariff 1 Date
Peak power P+max Tariff 2
Peak power P+max Tariff 2 Hour
Peak power P+max Tariff 2 Date
Peak power P+max
Peak power P+max Date
Peak power P+max Hour
Accumulated peak power P+max akk
Date
Hour
Hour counter
Number of debiting periods
Power threshold counter
Pulse input

Optical reading

An optical infrared sender and receiver according to IEC 62056-21 is placed on the front of the electricity meter to the left.

This optical reading can be used to read data or to configure e.g. display set-up and pulse figure.

By using METERTOOL for kWh meter, the meter's 3-display readings can be configured. Furthermore the integration period, target date for debiting logger and debiting logging interval can be changed.

Finally the pulse input on the meter can be scaled and tariffs can be changed.

It is not possible to change the meter's legal data without breaking the verification seal.

Functions

S0 pulse output

Emits pulses of active energy at 1000 pulses per kWh. The pulses are emitted synchronously with the LED.

The S0-output is specified according to the standard DIN 43864.

The maximum voltage, which may be connected to the S0 output, is 27 VDC (at 1 kΩ), and the maximum current, which may be drawn through the output, is 27 mA.

The pulse duration is 30 msec.

Plug-in modules

If needed, Kamstrup 382 can be extended by a plug-in module without subsequent reverification.

The module area communicates with the electricity meter's microprocessor via an internal data bus on the 6 pole internalconnection.

This provides innumerable functional possibilities, extra pulse output, tariff modules, power supply modules and data communication via GSM/GPRS, PLC, TCP/IP or radio.

Kamstrup 382 C and 382 E

These 2 meter types have build in radio communication on the electricity meter's main circuit board.

This is to optimise the product and eliminates the need for mounting the radio module subsequently.

When the meter's module area is used with an other type of communication, the integrated radio communication will be deactivated.

Kamstrup 382 D and 382 E

These 2 meter types have build in disconnect function.

This means it is possible to disconnect the mains output from the electricity meter.

The disconnection can be done locally by using the meter's push button, by METERTOOL for kWh meter or remotely by a connected reading system.

The disconnection must **NOT** be used as a safety switch.

The meter can be connected with the same media as it has been disconnected.

Approved measuring data

The meter is type approved according to the Measurement Instrument Directive (MID) for active positive energy and according to national requirements for other energy sizes.

Approval

Type test according to
– Active positive energy

– Reactive energy as well as
active negative energy

Norm

EN 50470-1
EN 50470-3

IEC 62052-11
IEC 62053-21
IEC 62053-23

Approval

Terminal according to

S0 pulse output according to

Optical reading according to

OBIS codes according to

Norm

DIN 43857

DIN 43864

IEC 62056-21
(IEC 61107)

IEC 62056-61

Technical data

Measuring principle

- Current Single phased current measurement by current shunt
- Voltage Single phased voltage measurement by voltage divider

Nominal voltage U_n 3x230V \pm 10%
 (only for Aron meter)
 1x230V \pm 10%
 2x230/400V \pm 10%
 3x230/400V \pm 10%

Current $I_b(I_{max})$

382BC	382DE 35 mm ²
5(105)A 35 mm ²	
10(60)A	10(65)A
10(85)A	
5(85)A	5(65)A

Class A
 B

Nominal frequency f_n 50Hz \pm 2%

Phase displacement Unlimited, not for Aron meters however

Operating temperature -40°C - +70°C

Storage temperature -40°C - + 70°C

Protective class IP52

Protection class II

Relative humidity < 75% year's average at 21°C
 < 95% less than 30 days/year, at 25°C

Weight

382 BC	382 DE
Approx. 680 g	Approx. 1200 g

Application area Indoors or outdoors in suitable meter cabinet

Internal consumption.

	382 BCDE
Current circuit	0.01 VA
Voltage circuit	0.5 VA, 0.1 W

Material

- Cover Transparent polycarbonate
- Base Glass reinforced polycarbonate

Data storage EEPROM
 > 10 years without voltage

Display LCD, 7mm-digit height (Value- and unit fields)
 LCD, 5mm-digit height (Identification readings)
 LCD, 3mm-digit height (voltage- and tariff-readings)

Meter constant 1000 imp./kWh,
 1000 imp./kvarh

Real Time Clock (RTC)

Accuracy Typical 5 ppm at 23°C

Real time clock backup
 - Battery life > 10 years at normal operation
 - Supercap life > 10 years at normal operation

Supercap operating hours A week fully charged

S0-pulse diode 1000 imp./kWh, kvarh
 Pulse duration 30 ms \pm 10%

S0-pulse output 1000 imp./kWh, kvarh
 Pulse duration 30 ms \pm 10%

Short circuits level 4500 A²t

Connection modules

The meter can be supplied or retrofitted with the following inputs and outputs from main circuit board by connection modules, without reverification.

S0 Supply	Sends 24 V via a two wire and pulses, by pulling down the supply at 0 V at each pulse.
Data/pulse	Serial RS232 communication, open collector, 300/1200 baud. Maximum load (current).

Pulse value Imp/kWh, Imp/kvar	Pulse width/ Pulse pause	
	30 msek	80 msek
1	105A	105A
10	105A	105A
100	105A	105A
1000	86A	32A
10000	8,6A	3,2A

M-Bus	Remote reading via M-Bus system.
2 tariffs Current Loop	Tariff control via external 230 VAC. Tariff control of 2 or 4 tariffs, CS and 230 VAC.
PLC	Remote reading via power line communication.
TCP/IP	Remote reading via TCP/IP communication.
GSM/GPRS	Remote reading via GSM/GPRS communication. Supports SMS reading.
Radio	Remote reading via radio communication. Build-in in 382C and 382E.

Connections

Measuring circuit	1.5 – 25 mm ² 1.5 – 35 mm ² Elevating connections	Voltage terminal	0.25 – 1.5 mm ² , 5 mm Cable terminal forks
Screws	Pz 2 or straight slot Torque 2.5 – 3 Nm	Screws Torque 1Nm	TORX Tx 10

Installation

Connect the meter in accordance with the installation diagram on the meter's type label.

Depending on the configuration a fixed value will be displayed, or the display will change between selected indications every 10 seconds.

It is possible to change the display reading manually by activating the push button on the meter.

The available readings will depend on the meter's configuration.

3-phase, 4-wire

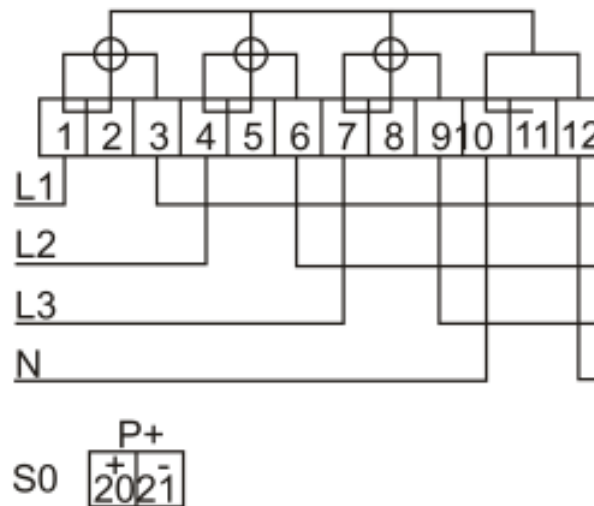

3-phase, 3-wire (Aron)

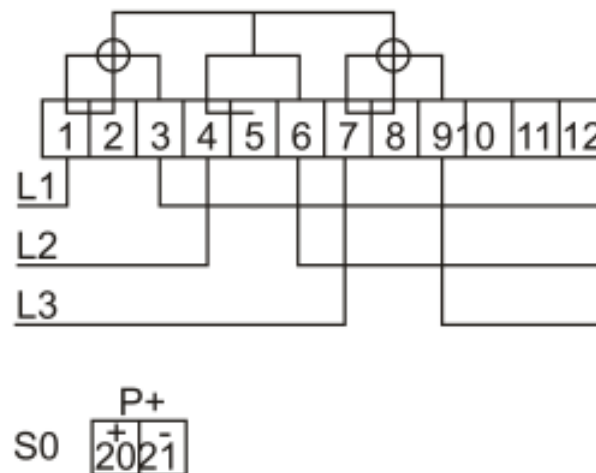

Connection diagrams

The valid connection diagram appears from the type label on the front of the meter.

Security and installation guide lines

The meter shall only be used for measuring electrical energy and shall operate within the specified values only.

The meter must be switched off when working on it. It can be highly dangerous to touch the meter parts when the meter is switched on.

Therefore, the relevant safety fuse must be removed and kept in a place where unauthorised persons cannot insert it.

Current local standards, guidelines, regulations and instruction must be observed. Only authorised personnel are permitted to install electricity meters. Meters for direct connection must be protected against short circuit by a backup fuse in accordance with the maximum current stated on the meter.

The meter constant LED blinks proportionally to the consumed active energy. Only authorised personnel must break the sealing.

Sealing

