

Blind actuator with manual actuation

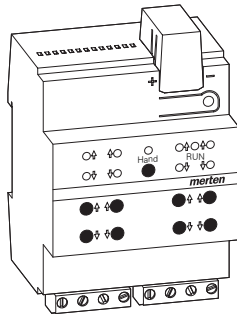

Table of Contents

1. Function	1
2. Installation	2
3. Operation	3
4. Technical data	5
5. Settings in the EIB Tool Software (ETS)	5
5.1 Blind 5700/1.0	6

1. Function

When used with INSTABUS EIB, the blind actuator can control several blind and roller shutter drives independently of one another. You can connect one blind or roller shutter motor with end position switches to each channel, and control these via INSTABUS push-buttons or binary inputs.

You can switch the blind actuator to manual operation, and check its function even without ETS programming.

The blind actuator has an integrated bus coupler. It is installed on a DIN rail, with the bus connection made via a bus connecting terminal.

Connections, displays and operating elements

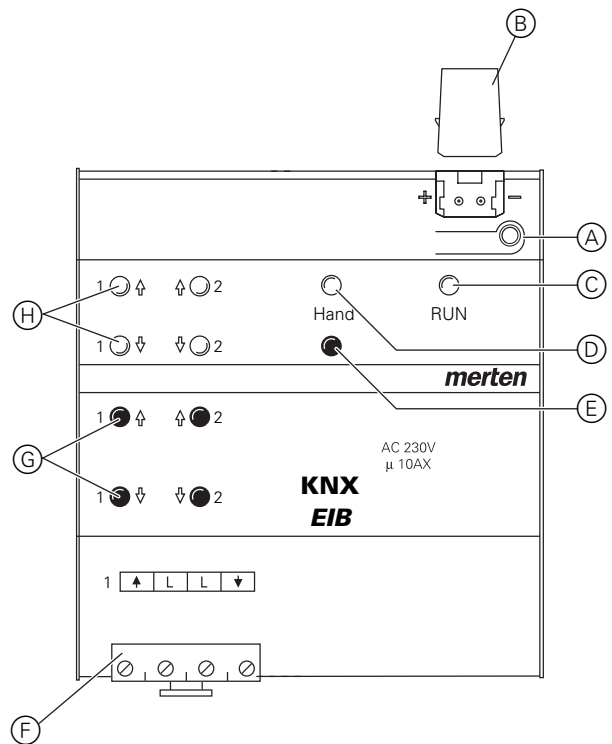

- Ⓐ: Programming button and programming LED (red)
- Ⓑ: Under the cable cover: Bus connecting terminal
- Ⓒ: Operating LED "RUN" (green)
- Ⓓ: Manual operation LED (red)
- Ⓔ: Toggle key for manual operation "On/Off"
- Ⓕ: Channel terminals for blind/roller shutter motor connection
- Ⓖ: Channel keys for manual control of the corresponding channel; only communicate when manual operation is "On"
- Ⓗ: Channel status LEDs (yellow) for the corresponding channel

2. Installation



Risk of fatal injury from electric current

The blind actuator may only be installed and connected by professional electricians. Observe the regulations valid in the country of use, as well as the valid EIB guidelines.



Risk of fatal injury from electric current

The switch outputs have a bistable relay. The switch contacts of these outputs can be changed to the enabled state due to strong vibrations during transportation. **Voltage may be present at the outputs when the mains voltage is connected to the system!**

After commissioning, you can set the outputs to the required position with a simple "ON/OFF" switching cycle using telegrams.

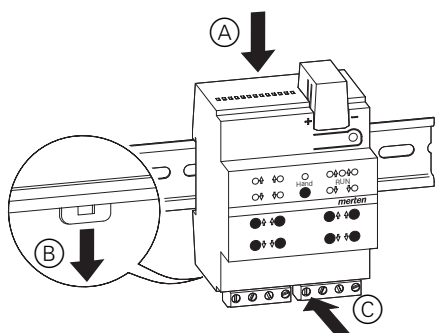

- ① Place the blind actuator on the DIN rail.



Caution! The blind actuator could become damaged. Protect switching contacts by connecting a 10 A automatic cutout upstream.

- ② Connect EIB:

(A)

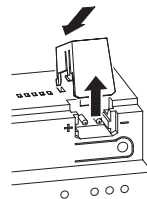

(B)

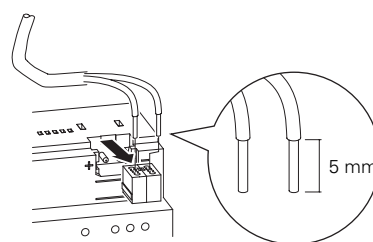

(C)

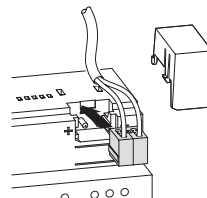

(D)

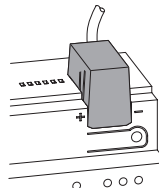

Caution! Connect the bus voltage to the blind actuator first and only then the mains voltage for the motor; otherwise, the motor could be damaged.

- ③ Connect the bus voltage..

- ④ Wait at least 30 seconds.

After the bus voltage has been connected, all the blind actuator relays will be moved to a predefined position (default setting: "Off").



Caution! The default reversing time on delivery is 500 ms. To prevent damaging the motor, a longer reserving time may be necessary for other motors (observe the specifications of the drive manufacturer).

⑤ Connect the blind or roller shutter as shown below:

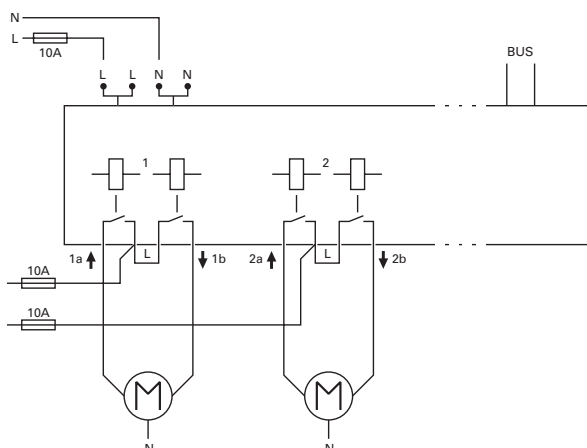

⑥ Switch on the mains voltage for the motor.

Now you can check that the blind actuator and connected motors work without having to load the application from the ETS (see section "Operation", "How manual operation works").

3. Operation

Commissioning the blind actuator

- ① Press the programming button.
The red programming LED lights up.
 - ② Load the physical address and application into the blind actuator from the ETS.
The red programming LED goes out.
- When the application has been loaded successfully and the blind actuator is ready for operation, the green operating LED "RUN" lights up.

How manual operation works

Normally, you control the blind or roller shutter using push-buttons or by remote control. However, you can also switch the blind actuator to manual operation and then raise or lower each blind manually using its channel keys. In order to be able to do this, the ETS parameter "Manual operation enabled" must be set to "enabled" and mains or bus voltage must be present.

Manual operation before downloading the application for the first time

You can switch the blind actuator to manual operation immediately after initial installation, e.g. in order to test the connections of the blinds.

Manual operation with the ETS setting "Bus and manual operation"

In manual operation, the blind actuator also responds to EIB telegrams. The command last received is given priority. Exception: Safety alarms (e.g. weather) always have priority with this setting.

Manual operation with the ETS setting "Manual operation only"

In manual operation, the blind actuator does not respond to EIB telegrams, nor to safety alarms! This setting can be useful when carrying out maintenance, for example.



Caution! When operating blinds or roller shutters in "Manual operation only" using the channel keys, safety functions such as weather alarm position, alarm position, disable position or travel range no longer work. To prevent damage to the blind/roller shutter, you should therefore be very careful when operating manually!



Note: Make sure that the ETS parameter "Manual operation type" is set to "Bus and manual operation" (not "Manual operation only") when you hand over the system to the operator.

Time-limited manual operation is another function that can be set in the ETS. With this function, you can set a time period after which manual operation (including "Manual operation only") is cancelled automatically. The blind actuator then responds to EIB telegrams again.

How to set the blind actuator to manual operation

① Press the toggle switch for "manual operation" The red "Manual operation" LED lights up. The blind actuator is in manual operation.

The green operating LED "RUN" goes out when "Manual operation only" is set in the ETS.

The green operating LED "RUN" remains lit when "Bus and manual operation" is set in the ETS.

How to end manual operation

① Press the toggle switch for "manual operation" again.

The red LED goes out. The green operating LED "RUN" lights up. The blind actuator now only responds to EIB telegrams.

How to control the blind/roller shutter in manual operation

① To raise (arrow up) or lower (arrow down) the blind or roller shutter: Press the corresponding channel key.

② To halt: Press the channel key again.

The corresponding channel status LED lights up during movement.

What should I do if there is a problem?

Here you will find possible reasons for malfunctions and how to remedy them.

The red manual operation LED "Manual" and the green operating LED "RUN" are not lit. Manual operation cannot be activated

- Bus voltage has failed. Check the bus voltage.

The green operational LED "RUN" is not lit

- The bus voltage has failed. Check the bus voltage.

- Application was not loaded properly. Load it again.

- Red "Manual" LED lights up: Manual operation is activated and "Manual operation only" is set in the ETS; only manual operation is possible, there is no malfunction. Switch off manual operation.

Blind actuator does not respond to the "Manual" toggle switch. The red "Manual" LED is not lit. Manual operation is not possible.

- ETS parameter "Manual operation enabled" is not enabled, there is no malfunction.

Set the parameter "Manual operation enabled" to "enabled"

- "Manual operation enabled" is blocked by an object (value=0), there is no malfunction,

release manual operation via object.

In manual operation, the blind actuator does not respond to the channel keys being pressed; the red "Manual" LED is lit; manual mode is not possible.

The green operational LED "RUN" is still lit: ETS parameter "Manual operation type" is set to "Bus and manual operation". A higher-level function (e.g. weather alarm or lock) is active. There is no malfunction.

Wait until the higher-level function has been completed, or switch the ETS parameter "Manual operation type" to "Manual operation only". Observe the safety note in the section "How manual operation works"!

In manual operation, the blind actuator controls connected motors without a channel key being pressed.

ETS parameter "Manual operation type" is set to "Bus and manual operation". The control command for the blind actuator came via an EIB telegram. There is no malfunction. Switch the ETS parameter "Manual operation type" to "Manual operation only". Observe the safety note in the section "How manual operation works"!

4. Technical data

Supply from EIB:	DC 24 V, max. 17.5 mA
Insulation voltage:	4 kV AC between bus and switch outputs
Nominal voltage:	AC 230 V
Nominal current:	10 A, inductive load $\cos j = 0.6$
Nominal power of motor	max. 1000 W at AC 230 V
Switching frequency:	max. 15x per minute at nominal load
Ambient temperature	
Operation:	-5 to +45 °C
Storage:	-25 to +55 °C
Transport:	-25 to +70 °C
Environment:	can be used at up to 2000 m above sea level (MSL)
Max. humidity:	93%, no moisture condensation
Operating elements:	1 programming button
	1 "Manual" toggle switch for manual operation
	2 channel keys per channel
Display elements:	1 red LED: Programming control
	1 green LED: ready for operation, "RUN"
	1 red LED: Manual operation status
	2 yellow status LEDs per channel
EIB connection:	two 1 mm pins for bus connecting terminal
External cable connection:	per channel one plug-in 4-gang screw terminal for max. 2.5 mm mm ²

5. Settings in the EIB Tool Software (ETS)

Selection in the product database

Manufacturer:	Merten
Product family:	4.5 Blind actuator
Product type:	4.5.01 DIN rail-mounted REG-K
Program name:	Blind 5700/1.0
Media type:	Twisted Pair
Product name:	Blind actuator REG-K/8x/10 with manual mode
Order number:	649802, 649804

The application is ETS 3 compatible.



To guarantee the full functionality of the applications under ETS2, ETS2 version 1.2 or higher and Service Release A or higher should be used. If you have any queries, contact the Merten infoline.

Application overview

Application overview

Application	Vers.	Functions
Blind 5700/1.0	1	Moving height position and slat opening angle manually
		Move height position and slat opening angle using absolute position commands
		Automatic control
		Calibration/Reference movement
		Disable function for manual operating options
		Preset function
		Scene function – Integrating the blind actuator into scene control
		Weather alarm
		Alarm function
		Disable function
		Limitation of the movement range
		Status response
		Operating display

5.1 Blind 5700/1.0

● **General information**

This software application allows you to program series REG K/x/10 blind actuators with manual operation, which in turn allows you to control connected blind or roller shutter drives. The ETS allows you to individually set the type of connected load, as well as the functions available to it, for each of the blind actuator's output channels.

You can also operate the blind actuator using the push-buttons on the front. For more information see the section "Operation".

All the settings described refer to ETS version 3, but you can use all the settings and functions with ETS version 2 as well.

Maximum number of group addresses: 252

Associations: 252



Caution!

If you switch back to the preset values in either ETS 2 or ETS 3 (by clicking "Standard"), then all the values that you have changed so far will be deleted!



Note: Due to the fact that various functions depend on other functions, these dependant functions are only visible and selectable in the ETS when the preceding function has been enabled. If you de-select functions or parameters, group addresses that have already been connected may be deleted.



Note: Due to the fact that the output relays of a channel are locked against each other, you cannot switch on both outputs of the channel in question at the same time.



Note: The application files (vd2 and vd3) are configured in such a way that the application loading time is considerably reduced. When you convert a ETS 2 project to ETS 3, you lose this time saving. It therefore makes sense to load the vd3 file when using ETS 3.

● **Application functions**

The software application for the blind actuator provides you with numerous functions, which can be broken down into three groups. The description of the functions specifies and explains the parameters that are relevant for these functions. You will find an overview of all the parameters of the ETS application for the blind actuator in the last section "Parameters and settings".

Basic functions

These functions allow you to commission the device and equip it with simple functionality.

- Move height positions and slat opening angle manually

Advanced functions

- Move height position and slat opening angle using absolute position commands
- Automatic control
- Calibration/Reference movement
- Disable function for manual operating options
- Preset function
- Scene function

Higher-level functions

Higher-level functions are executed before the basic function and advanced functions. There are four higher-level functions:

- Weather alarm
- Alarm function
- Disable function
- Limit travel range

You can select the priorities freely:

Tab	Parameter
General	Priority sequence of higher-level functions

A higher-level function only becomes active if there is no other higher-level function active at the same time. If a higher-level function is reset and there is another higher-level function of lower priority active at the same time, then the actions of the lower priority function are then carried out.

● **Defining blind type**

If you want to define parameters for a blind, you need to specify the type of your blind before you start programming.

The application differentiates between four types of blind. You can determine the blind type from the position of its slats during movement. Two of these types have a mechanically-determined working position. You can recognise these by the tilted position of the slats when moving downwards. The working position restricts the possible opening angle of the slats, as long as the blind has not reached its lower end position.

Blind type 1 (without working position)

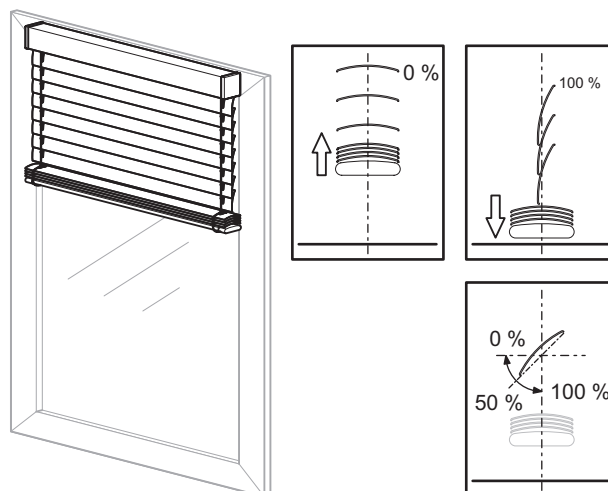

- Upward movement: Slats are in a level, opened position (slat position 0 %)
- Downward movement: Slats are closed downwards (slat position 100 %)
- Possible regulating range for the opening angle of the slats: 0–100 %

For each channel, you can use the "Slat position after movement" parameter to specify the behaviour of the slats following a movement. If you set the parameter to "Working position", you can configure the opening angle that you want the slats to assume after each downward movement. The preset value of 50 % corresponds to a slat opening of approximately 45°. Due to the fact that this position is time-controlled, please note the section "Running times of the drives".

i Note: Unless stated otherwise, the examples in the following set of instructions refer to this type of blind.

Blind type 2 (with working position)

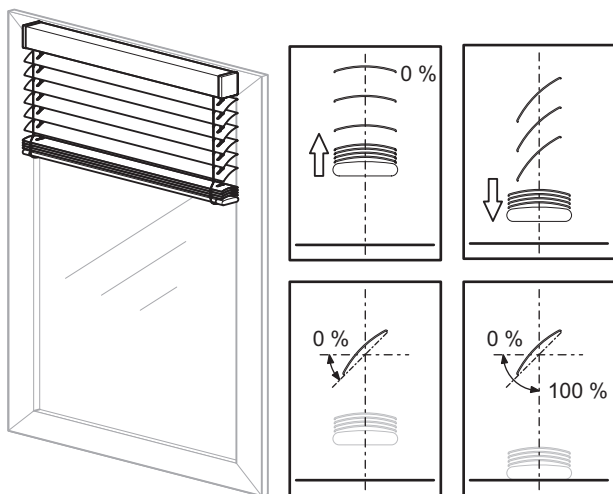

- Upward movement: Slats are in a level, opened position (slat position 0 %)
- Downward movement: Slats tilted in working position downwards (slat position in working position)
- Possible regulating range for the opening angle of the slats:
0 % to working position, if blind is not in lower end position
0–100 %, if blind is in lower end position

You can use the parameter "What is the current slat position on downward movement in %?" to configure the opening angle for the working position.

Blind type 3 (without working position)

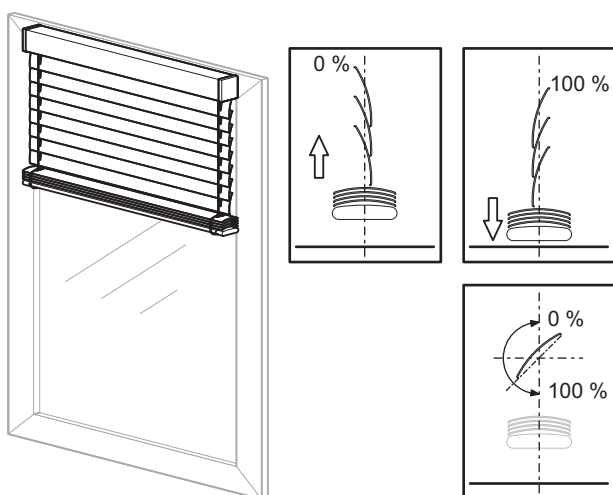

- Upward movement: Slats are closed upwards (slat position 100 %)
- Downward movement: Slats are closed downwards (slat position 100 %)
- Possible regulating range for the opening angle of the slats: 0–100 %

For each channel, you can use the "Slat position after movement" parameter to specify the behaviour of the slats following a movement. If you set the parameter to "Working position", you can configure the opening angle that you want the slats to assume after each downward movement. The default value of 50% corresponds to a slat opening of approximately 45°. Due to the fact that this position is time-controlled, please note the section "Running times of the drives".

Blind type 4 (with working position)

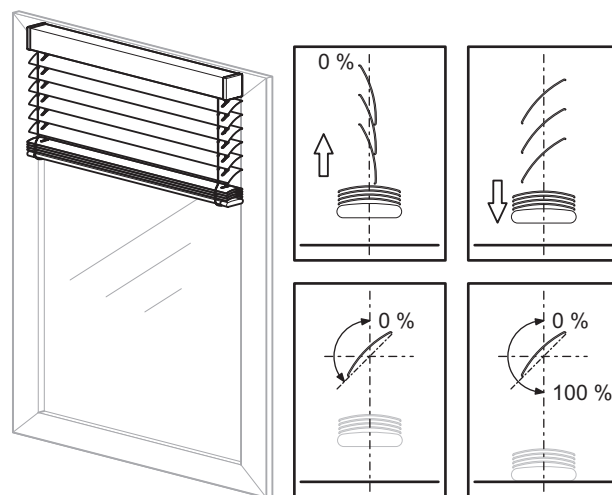

- Upward movement: Slats are closed upwards (slat position 100 %)
- Downward movement: Slats tilted in working position downwards (slat position in working position)
- When the lower end position is reached, the slats are closed (slat position 100 %)
- Possible regulating range for the opening angle of the slats:
0 % to working position, if blind is not in lower end position
0–100 %, if blind is in lower end position

You can use the parameter "What is the current slat position on downward movement in %?" to configure the opening angle for the working position.

What blind type to select in the ETS?

For the corresponding blind type setting, you can configure the "How does the existing blind move?" parameter in the "X: Blind" tab as follows:

Tab	Parameter
X: Blind	How does the existing blind move?

Blind type	Setting
1	downwards closed / upwards level
2	downwards tilted / upwards level
3	downwards closed / upwards closed
4	downwards tilted / upwards closed

Also configure the following parameters.

For type 1 and 3:

Tab	Parameter
X: Blind	Slat position after movement
	Slat working position in %

For type 2 and 4:

Tab	Parameter
X: Blind	What is the current slat position on downward movement in %

Slat adjustment function

Every time the blind moves, the position of the slats also changes depending on the direction of movement. After movement, the slats remain in this new position. This application, however, allows you to automatically adjust or reset the position of the slats after a movement.

Use the "Slat position after movement" parameter to specify the behaviour of the slats after a movement for each blind channel.

Tab	Parameter
X: Blind	Slat position after movement

The following parameters are available:

- no response (slats remain in the current position)
- working position (slats are moved into the working position)
- last slat position (the slats resume the opening position that they had before the movement started)

The slat opening angle that you specify here is applied after every positioning movement of the blind and also after every manual movement command ended by a stop telegram.

After a bus voltage failure or a download, the last slat position is not clearly defined. As a result, the corresponding working position is used as the last slat position.

Running times of the drives



Note: Selecting the smallest possible value as the time basis in each case allows you to

achieve the most precise results for the internal device time setting.

The importance of the drive running times setting depends on the desired control task for the blind or roller shutter.

The application provides you with the following parameters for setting running times:

- Height running time
- Slat step interval (for blind function)
- Slat running time (for blind function)
- Pause on reverse for change of direction

You also have various options for compensating small time deviations caused by physical conditions or technical drive properties:

- Running time upwards supplement
- Dead time until upwards movement
- Start-up delay
- Run-out delay
- Slat open up start-up supplement (for blind function)
- Slat open down start-up supplement (for blind function)

Selecting the smallest possible value as the time basis in each case allows you to achieve the most precise results for the internal device time setting.

Tips for setting values

If the running times to be set are too short to measure with the clock, then set an approximate value for the time being. Use position commands to test the behaviour of the drive or the slats. If the desired positions are not fully reached, then correct the running times upwards. If the positions are overshoot, then correct the running times downwards. Use new position commands to check your corrections. Carry out several tests because you will only see or detect the small discrepancies after a few movements.

When making corrections, it makes sense to change the value for the running time factor and to leave the value for the running time basis the same.

In addition to the discrepancies mentioned, environmental factors (temperature, rain etc.) also lead to variations in the movement behaviour of the drives. Due to the fact that the drives cannot report their current position and the current position can't always be calculated, the blind actuator cannot detect these discrepancies. In order to continue to be able to position the drive precisely, it makes sense to return the drives to a fixed starting position by means of regular reference movements. This allows you to achieve satisfactory positioning precision for a long time.

For more information, refer to the section "Calibration/Reference movement".

Running times for basic function

You only have to measure and set the following running times in order to configure a simple basic function:

Height running time

Tab	Parameter
X: Drive	Time basis for height running time
	Factor for height running time (10-64000) 1 second = 1000 ms

The running time is always comprised of the time basis multiplied by the factor, e.g. (default value):

$100 \text{ ms} * 1200 = 120 \text{ s}$

The drive needs this period of time to move out of one end position (blind/roller shutter is fully open or closed) into the opposite end position. When the set running time expires, the relay of the corresponding channel is automatically switched off (even if the drive with the values set here has not fully reached its end position). You may want to check whether the drive manufacturer has made any specifications regarding running times.

Slat step interval (only for blind)

Step commands allow you to turn the blind slats. You can change the opening angle of the slats gradually, to prevent glare when the sun changes position for example. Time basis multiplied by factor allows you to configure the duration of this kind of gradual rotation.

Tab	Parameter
X: Drive	Time basis for slat step interval
	Factor for slat step interval (5-255)

Example (default values):

$10 \text{ ms} * 10 = 100 \text{ ms}$

Depending on the total running time in one direction of movement, the step interval allows you to provide the user with a certain number of steps for opening or closing the slats.

If the running time is 2.5 s for example, then the drive needs approx. 25 steps to go through the entire slat opening range in one direction ($2.5 \text{ s} / 100 \text{ ms} = 25 \text{ steps}$).

Using the same example, if you only want to give the user five slat steps:

$2.5 \text{ s} / 5 \text{ steps} = 0.5 \text{ s step interval}$

Leave the time basis of the step interval at 10 ms and set the factor of the step interval to 50:

$10 \text{ ms} * 50 = 0.5 \text{ s step interval}$

Slat running time (only for blind)

The slat running time is the period of time it takes the slat to complete a full movement from 0% to 100% (or vice versa). The regulating range through which the opening angle passes depends on the type of blind in use:

	Type 1	Type 2	Type 3	Type 4
Slat position 0 %	level open	level open	up closed	up closed
Slat position 100 %	down closed	down closed	down closed	down closed

Tab	Parameter
X: Drive	Time basis for slat running time
	Factor for slat running time (5-255)

Example (default values):

$10 \text{ ms} * 100 = 1000 \text{ ms} = 1 \text{ s}$

How to measure small slat running times:

- Move the slats into the closed position (slat position 100 %). This is the lower end position for blind types with working position.
- Count step commands: Now send step commands until the blind moves up, counting the number of steps required.

Example: The blind requires five steps to go through the slat regulating range. The blind moves upwards on the sixth step.

- The step interval values set (default step interval: 100 ms) is used to calculate the slat running time: $100 \text{ ms} * 5 \text{ steps} = 0.5 \text{ s}$

How to measure large slat running times

- Move the slats into the closed position (slat position 100 %). This is the lower end position for blind types with working position.
- Now send a movement command upwards. Before the drive opens the blind, the slats turn into the open position (0 %). Measure the time it takes them to turn.
- Stop the drive after turning.
- For blind type 2 and 4 (with working position), ensure that the closed slat position is not engaged until in the lower end position. Then also add on the time it takes to turn from the working position to the closed position.

i Note: For blind types 1 and 3 (without working position) your setting for the slat running time influences the opening angle after a movement. This is because the selected opening angle (percentage of automatic slat position) is converted into a percentage turning time for the

slats. The same applies for the slat adjustment function after a movement.

Pause on reverse for change of direction

When the blind actuator of a drive that is currently moving receives a command to move in the opposite direction, then it first switches off both output relays for this channel. Before it switches on the relay for the new direction, it waits for the pause on reverse interval to pass. Set the length of the pause on reverse using the factor:

Tab	Parameter
X: Drive	Pause on reverse for change of direction (1-255) factor * 100 ms, manufacturer data!

100 ms is the underlying time basis. Example (default values):

$$5 * 100 \text{ ms (fixed value)} = 500 \text{ ms}$$

The blind actuator also observes the pause on reverse if, when executing two step commands, it has to turn the slats in different directions.



Caution!

Pauses on reverse that are too short could cause damage to the drive.

When setting values, observe the manufacturer's specifications for the drive under all circumstances.

Running times for advanced functions and positioning commands

The advanced functions and direct positioning commands allow you to move the connected blinds or roller shutters into the desired position directly and, in the case of blinds, configure the opening angle of the slats also.

Tab	Parameter
X: Drive	Advanced drive parameter

Due to the fact that the actuated drive cannot provide any status feedback on its position, these positioning movements are time controlled. Here it is important to set the running time parameter as precisely as possible because the more precisely you set this parameter, the more precisely the desired position can be determined and engaged. This is particularly the case for buildings that demand sophisticated blind control.

Positioning will be more precise the slower and longer a drive moves.

The settings for the height running time have already been explained. You can also set the following parameters contingent upon physical circumstances and the drive.

Running time upwards supplement

The running time supplement only applies for upward drive movements. This is due to the physical fact of gravity: it takes drives longer to move up than down. Due to the fact that this time variation can be very short, you need to carry out a few movements in order to become aware of this behaviour. It's a good idea to move the drive from 10% to 90% and back to 10% again a few times. If, after these movements, you observe that the drive doesn't quite reach the top end position any more, you can compensate as follows:

Tab	Parameter
X: Drive	Shared time basis for running time supplements/dead time
	Factor for running time upwards supplement

Example (default values):

$$10 \text{ ms} * 20 = 200 \text{ ms}$$

Dead time until upwards movement

If, when in the closed lower end position, the used blind experiences dead time between the time when the main band is activated and the first upward movement, then you can compensate for this delay as follows:

Tab	Parameter
X: Drive	Advanced drive parameter
	Shared time basis for running time supplements/dead time
	Factor for dead time to upward movement (1-255)

Example:

$$10 \text{ ms} * 10 = 100 \text{ ms}$$

You can also use the dead time to compensate for the roller shutter opening when using a roller shutter.

Start-up delay / Run-out delay

Some motors do not achieve maximum output immediately when they are switched on, but a few milliseconds later. You can compensate for this using the start-up delay time setting.

Some motors continue to run for a few milliseconds after they have been switched off. If you observe this behaviour, then you can compensate with the settings for run-out delay.

Tab	Parameter
X: Drive	Advanced drive parameter
	Factor for start-up delay Factor * 10 ms
	Factor for run-out delay Factor * 10 ms

Start-up delay example:

$$10 \text{ ms} * 2 = 20 \text{ ms (with a time basis of 10 ms)}$$

Slat running time with time-controlled positioning

In addition to the specifications already described for the slat running times, the following values apply in the case of time-control positioning:

- 0 %: Slats open or in the top closed position
- 100 %: Slats closed or in the bottom closed position

The resulting opening angle depends on the type of blind in use.

The device converts the set slat running time to a value between 0% and 100% accordingly and calculates the resulting travel times for the desired position commands.

Start-up supplement

When opening the slats, some blind types need an extra start-up supplement until the slats start to respond depending on the tightening and loosening of the slat cords. This depends on the current position of the slats. You can use the following parameter to set a start-up supplement for both the top and bottom slat position.

These parameters allow you to set the start-up delay for an upwards movement until the slat turns when the slats are in the open position (0%) (the previous blind movement was an upwards movement):

Tab	Parameter
X: Drive	Advanced drive parameter
	Shared time basis for running time supplements/dead time
	Factor for slat open up start-up supplement

The start-up delay until the slat turns that you specify here is always considered when the blind is opened if the slats are in the closed position (100 %) (the previous blind movement was a downwards movement):

Tab	Parameter
X: Drive	Advanced drive parameter
	Shared time basis for running time supplements/dead time
	Factor for slat open down start-up supplement

i Note: For every slat movement, it is assumed that the drive is switched on for a minimum running time. This minimum running time of the slat results from the switching capacity of the blind actuator's relay and is approx. 20 ms. Slat movements that are mathematically less than 20 ms are not carried out.

● **Basic functions: Moving height position and slat opening angle manually**

The basic function allows you to move the connected drive into the desired position manually. You have two communication objects to do this: "Manual movement object" and "Manual stop/step object" (for roller shutters: "Manual stop/step object").

- Move drive
The "Manual movement object" is responsible for opening and closing the blind or the roller shutter. When the value "1" is received, the drive moves down; "0" moves it up.
- Running time
The active output remains active until the set running time expires. If a new movement command in the same direction is received, then the drive continues moving.
- Pause on reverse for change of direction
If, during a drive movement, a control command in the opposite direction is received, then the drive stops and waits for the defined pause on reverse time before moving in the new direction of movement.
- Stop drive
When a drive that is currently moving receives a bus telegram for the "Manual stop/step object" (for roller shutters: "Manual stop/step object"), it stops. The object value received is irrelevant.
- Slat adjustment
If the drive has been stopped, then the slats are turned into the desired position depending on the settings for the "Slat position after movement" parameter.
- Turn blind slats
The "Manual stop/step object" allows you to adjust the opening angle of the slats gradually for blinds. The drive must be idle. If the communication object receives the object value "1", then the slats are closed by one increment; if "0" is received, they open by one (type 1).

Note the following special cases:

1. If a step command is executed and the slats subsequently reach the limit of their possible movement range or if they are already in a maximum position, then the drive moves briefly in the desired direction. The duration of this movement also corresponds to the set step time.
2. If the direction changes from one step command to the next, then the device waits the pause on reverse time between steps in this case also.

Parameter settings in the ETS:

Set the following parameters for this function in the ETS:

Tab	Parameter	Blind	Roller shutter
Channel configuration	Channel X operating mode	X	X
X: Blind	How does the existing blind move?	X	
	Slat position after movement	X	
	Slat working position in %	X	
	What is the current slat position on downward movement in %	X	
X: Drive	Time basis for height running time	X	X
	Factor for height running time (10-64000) 1 second = 1000 ms	X	X
	Time basis for slat step interval	X	
	Factor for slat step interval (5-255)	X	
	Time basis for slat running time	X	
	Factor for slat running time (5-255)	X	
	Pause on reverse for change of direction (1-255) factor * 100 ms, manufacturer data!	X	X

Communication objects

Communication objects for blind:

Function	Object name	Type	Prio	Flags	Behaviour
Blind	Manual movement object	1 bit	Low	WC	Receive
Blind	Manual stop/step object	1 bit	Low	WC	Receive

Communication objects for roller shutters:

Function	Object name	Type	Prio	Flags	Behaviour
Roller shutter	Manual movement object	1 bit	Low	WC	Receive
Roller shutter	Manual stop object	1 bit	Low	WC	Receive

Settings for this function:

- "Manual movement object" = "0": Blind/Roller shutter open
- "Manual movement object" = "1": Blind/Roller shutter close
- Drive is moving and "Manual stop/step object" or "Manual stop object" = "0" or "1": Stop drive

Extra for blinds:

- Drive is idle and "Manual stop/step object" = "0": Slats one step upwards
- Drive is idle and "Manual stop/step object" = "1": Slats one step downwards.

Special cases:

- Slats in top end position (slat position 0 %) and "Manual stop/step object" = "0": Drive moves one step upwards
- Slats in bottom end position (slat position 100 %) and "Manual stop/step object" = "1": Drive moves one step downwards.

● **Advanced functions: Move height position and slat opening angle using absolute position commands**

This function allows you to manually set a height position, and in the case of blinds the opening angle of the slats, directly using a percentage value. The desired percentage value always relates to the possible movement range of 0–100 % that you set by specifying the running times. You therefore set an absolute height position for the entire movement range.

After receiving a new position value, the blind actuator calculates a proportional movement time from the current position and the new desired position and then moves the drive in the corresponding direction of movement for this period of time. The new position is buffered. The precision of the position settings depends on the precision of your settings for the drive running times.

After a few position movements, there will be minimal deviations between the actual position and the calculated position for physical and mechanical reasons. You can reset these deviations with reference movements.

If a reference movement is necessary before a new position movement, then the blind actuator allows this to be carried out before moving into the new setpoint position (see the section "Calibration/Reference movement").

The communication objects "Manual height position" and "Manual slat position" (for blinds) allow you to set the absolute position values.

- Set height position
The "Manual height position" object is responsible for the height position of the blind or roller shutter. The limit position 0 % means that the blind/roller shutter is fully up. If 100% is set, then the blind/roller shutter is fully down.
- Turn slats into opening position
The "Manual slat position" object allows you to set the slat opening angle directly. In slat position 0 % the slats are horizontally open or closed up. At 100 % they are closed down. The actual opening angle of the slats depends on the type of blind in use.

When it receives a new position value, the blind actuator calculates the running time necessary to reach the new position from the current position. Then the drive is moved to the new position for the calculated period of time. The calculation also determines the direction of travel. If, during a positioning movement, the device receives a new position value and the calculation results in the same direction of travel, then the drive continues moving until it reaches the new setpoint position.

- Pause on reverse for change of direction
If, during a drive movement or slat adjustment, a new position command is received and the

calculation results in the opposite direction of travel, then the drive stops and waits for the defined pause on reverse time before starting the new position movement.

- Slat adjustment
When the height position of the blind is changed and the blind reaches the desired position, then the slat adjustment function is carried out and the slats are moved into the desired position.

Parameter settings in the ETS:

Set the following parameters for this function in the ETS:

Tab	Parameter	Blind	Roller shutter
Channel configuration	Channel X operating mode	X	X
X: Blind	How does the existing blind move?	X	
	Slat position after movement	X	
	Slat working position in %	X	
	What is the current slat position on downward movement in %	X	
X: Drive	Advanced drive parameter	X	X
	Time basis for height running time	X	X
	Factor for height running time (10-64000) 1 second = 1000 ms	X	X
	Shared time basis for running time supplements/dead time	X	X
	Factor for running time upwards supplement	X	X
	Factor for dead time until upwards movement	X	X
	Factor for slat open up start-up supplement	X	
	Factor for slat open down start-up supplement	X	
	Time basis for slat step interval	X	
	Factor for slat step interval (5-255)	X	
	Time basis for slat running time	X	
	Factor for slat running time (5-255)	X	
	Pause on reverse for change of direction (1-255) Factor * 100 ms, manufacturer data!	X	X
	Factor for start-up delay Factor * 10 ms	X	X
	Factor for run-out delay Factor * 10 ms	X	X

Blind 5700/1.0

Application examples

The following examples show the running times that result in order to reach certain positions.

Starting position and set values:

- Blind type 1, working position 50 %, slat adjustment = working position
- Running times:
 - Start-up delay disabled
 - Run-out delay disabled
 - Slat open up/down start-up supplement disabled
 - Height running time 120 s
 - Running time supplement upwards 0.2 s
 - Slat running time 2.5 s
- Current height position 0 % (blind up)
- Current slat position 0 % (slats open)

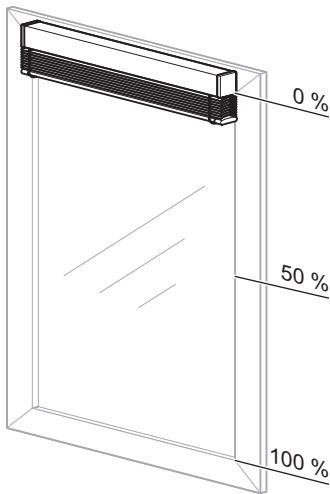

New height position: 50 %

- Step 1:
Close slats for downwards movement = **2.5 s**
(Slat running time from 0 % to 100 %)

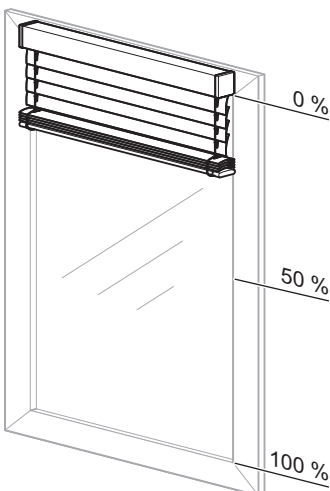

- Step 2:
Height running time = 60 s, downwards direction
(Difference between current 0 % and new position 50 % = 50 % of height running time)

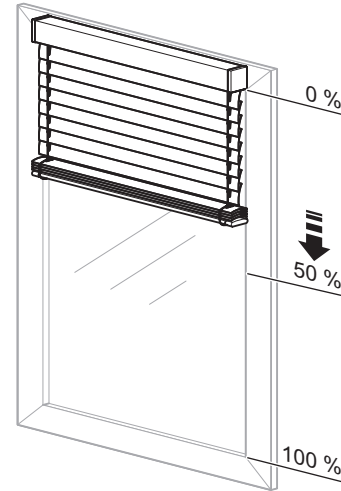

- Step 3:
Slat adjustment into the working position after downwards movement = **1.25 s**
(Slat running time from 100 % to 50 %)

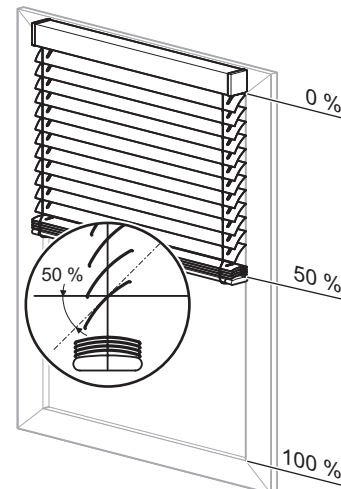

Total movement time therefore:
 $2.5 \text{ s} + 60 \text{ s} + 1.25 \text{ s} = \mathbf{63.75 \text{ s}}$

Blind 5700/1.0

New height position: 30 %

Step 1:

Open slats for the upwards movement = 1.25 s
(Slat running time from 50 % to 0 %)

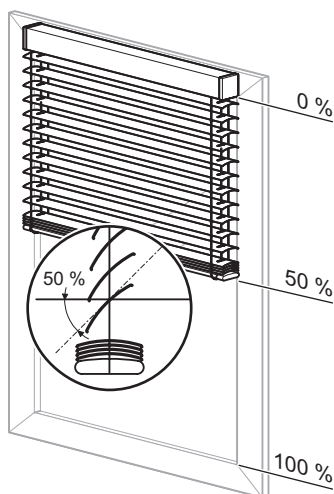

Step 2:

Height running time = 24 s, upwards direction
(Difference between current position 50 % and new position 30 % = 20 % of height running time)
plus

Running time supplement upwards = 0.04 s
(Difference between current position 50 % and new position 30 % = 20% of running time supplement)

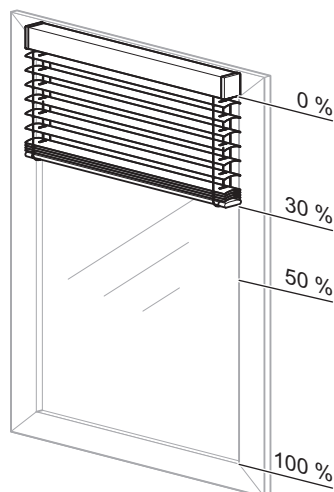

Step 3:

Slat adjustment into the working position after upwards movement = **1.25 s**
(Slat running time from 0 % to 50 %)

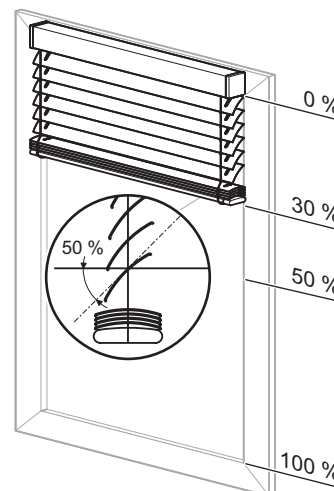

Total movement time therefore:

$$1.25 \text{ s} + 24 \text{ s} + 0.04 \text{ s} + 1.25 \text{ s} = \mathbf{26.54 \text{ s}}$$

New slat position: 20 %

Step 1:

Slat running time = 750 ms
(Difference between current position 50 % and new position 20 % = 30 % of slat running time)

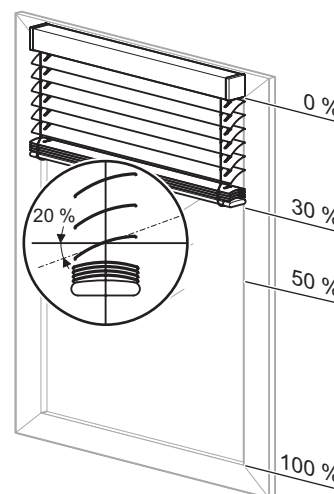

Communication objects

Communication objects for blind:

Function	Object name	Type	Prio	Flags	Behaviour
Channel X	Manual height position	1 byte	Low	WC	Receive
Channel X	Manual slat position	1 byte	Low	WC	Receive

Communication objects for roller shutters:

Function	Object name	Type	Prio	Flags	Behaviour
Channel X	Manual height position	1 byte	Low	WC	Receive

● **Advanced functions: Automatic control**

In addition to manual control of the blind/roller shutter drives (using the communication objects for the manual operation options), the software application **also** provides you with another group of communication objects for automatic control.

Automatic control can take place from other bus devices, e.g., presence detectors, light controllers or through a building control centre. When you have activated automatic control for a channel, then initially you can position the connected drive equally using manual or automatic control. The drive responds identically to control telegrams received from both types of control.

Using parameter settings and objects you can change the operating principle of both control options. You can also configure manual and automatic control to influence each other.

Activating automatic control

In order to be able to use automatic control, you have to activate the function in the ETS first:

Tab	Parameter
X: Blind X: Roller shutter	Automatic control/Presets

When automatic control is active, the extra tab "X: Automatic" appears. Here you can make more settings.

The communication objects for manual operation and automatic control have the same effects. The drive carries out the last command it received to one of the objects.

Deactivating/Disabling automatic control

If manual control and automatic control operating on an equal basis doesn't always suit your application, then you can disable the automatic function using another object if necessary, and then enable it again later.

In addition, you can specify how automatic control responds to a manual operating telegram.

Tab	Parameter
X: Automatic	Automatic lock

If you set "Automatic lock" to the value "on object value 0" or "on object value 1", then the communication object "Automatic lock" also appears.

Depending on how it is set, the automatic function is either enabled or disabled when it receives a new telegram value.

- "Automatic lock" = "on object value 0"
If "Automatic lock" = "0": Automatic function disabled (automatic lock active)
If "Automatic lock" = "1": Automatic function enabled (automatic lock inactive)
- "Automatic lock" = "on object value 1"
If "Automatic lock" = "0": Automatic function

enabled (automatic lock inactive)
If "Automatic lock" = "1": Automatic function disabled (automatic lock active)

You can also specify the behaviour of the drive at the end of an automatic lock.

Tab	Parameter
X: Automatic	Behaviour on deactivation of the automatic lock via object value

Specifying dependency between automatic function and manual control

The following parameter allows you to define the response of the automatic function to the receipt of a control telegram from the manual control options (manual movement object, manual stop/step object, manual height position, manual slat position and scene retrieval):

Tab	Parameter
X: Automatic	Response in automatic operation on receipt of a manual object value

If this parameter is set to "Automatic control temporarily disabled", two additional parameters appear:

Tab	Parameter
X: Automatic	Time basis for automatic function deactivation time
	Factor for automatic function deactivation time (1-255)

The deactivation time period results from the time basis x factor.

The only way to cancel a continuous deactivation of the automatic function is with a telegram to end an automatic lock via the automatic lock object. The action that you set in the parameter "Behaviour on deactivation of the automatic lock via object value" is executed.

After a time-limited deactivation has expired, the drive remains in its current position until it receives the next control telegram.

Communication objects

Function	Object name	Type	Prio	Flags	Behaviour
Channel X	Automatic movement object	1 bit	Low	WC	Receive
Channel X	Stop/step object automatic	1 bit	Low	WC	Receive
Channel X	Height position automatic	1 byte	Low	WC	Receive
Channel X	Slat position automatic	1 byte	Low	WC	Receive
Channel X	Automatic lock	1 bit	Low	CRW T	Send/ Receive/ Read out

● **Advanced functions: Calibration/Reference movement**

The blind actuator calculates the current position of a drive from the running times that you set for the drive and also from the control commands that it executes. This calculation has to be performed because the drive cannot provide any status feedback on its position. Even if you set the running times very precisely, small variations occur between the internally calculated height position and the actual height position after a few movements. These are due to mechanical tolerances and weather influences (temperature fluctuations, frost, rain etc.).

The blind actuator can reset these deviations with reference movements. To do this, it moves the drives specifically into the top or lower end position. After the reference movement, the internal position calculation re-starts from a fixed value. This means that any deviations that have occurred in the meantime are deleted.

i Note: The calibration function is primarily important if you are working with a lot of position commands and require a high level of positioning precision. If you are controlling the blind with the basic function only and position commands are irrelevant, then you don't need this function.

Operation

A reference movement can be triggered by a communication object or after a certain number of movements. When a reference movement is triggered, the drive moves into the desired reference position (end position). If you have set both end positions as reference positions, then the drive moves into the nearest end position, depending on its current position. In order to ensure that the drive reaches the end position fully, the actuator adds a running time supplement of 5% of the total running time to the calculated movement time for every reference movement.

Application example

- Blind type 1, automatic slat position after downwards movement (working position) 50 %
- Start-up delay: disabled
- Run-out delay: disabled
- Slat up start-up supplement: disabled
- Height running time 120 s
- Running time supplement upwards 0.2 s
- Slat running time 2.5 s
- Current height position 40 %
- Current slat position 50 % (work position)

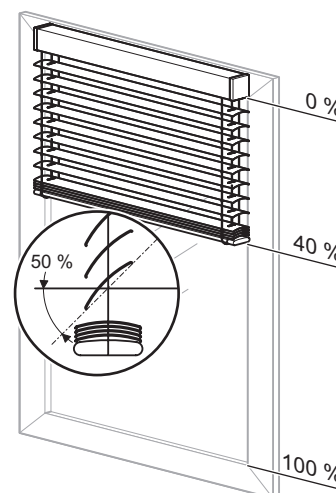

Calculated movement time for reference movement to top end position:

- Open slats fully for the upwards movement = 1.25s
- plus height running time (40 % of total movement range) 48 s, upwards direction
- plus running time supplement upwards (40 % of 0.2 s) 0.08 s
- Calculated movement time: 49.33 s
- plus supplement for reference movement (5 % of total running time) 6 s
- **Total movement time of the reference movement 55.33 s**

Calibration is also automatically carried out when the drive moves into an end position following a "normal" positioning command. The running time supplement of 5% also applies in the case of automatic calibration.

i Note: If during a calibration function a weather alarm or any other higher-level function is activated, then the calibrating function is cancelled and the higher-level function is executed.

You can activate the calibration function for every channel individually: Enable the "Calibration" parameter.

Tab	Parameter
X: Blind	Calibration
X: Roller shutter	

Blind 5700/1.0

A new tab "X:Calibration" appears for those channels for which you activated the calibration function. Here you can make the desired settings for each channel. Using the "Reference position" parameter, first select the end position that you want to use as the reference position.

Tab	Parameter
X: Calibration	Reference position

Then you can specify what triggers a reference movement:

Trigger reference movement after a certain number of movements

The actuator adds the number of all movements regardless of which control command triggered the movements. Once the defined number of movements has been reached, the drive carries out a reference movement before the next positioning command. Then it moves into the required position. After the reference movement, the movement counter is reset.

Trigger reference movement by communication object

When the "Trigger reference movement" object receives the value "1", a reference movement is started on all associated channels. So as not to overload the power supply of the blind system, you can stagger the reference movements by specifying a delay time for each individual channel. If during this delay time, the object receives a new value of "1", the delay time is restarted. The object value "0" has no meaning.

You can define the height position after the reference movement with the "Position after reference movement via object". If you want the drive to move into a new position, then set the height, and in the case of blinds the opening angle of the slats also, to a value in the movement range between 0% and 100%.

If the blind actuator receives an absolute positioning command during the reference movement, it moves into the desired position after the reference movement. The settings in the "Position after reference movement via object" parameter have no effect in this case. All other control commands interrupt the calibration function. The drive responds to the control commands received.

Automatic calibration

Every time the drive moves into the defined end position following a positioning command, the calibration function is carried out. This means that a running time supplement of 5% of the total running time is added to the calculated movement time needed by the drive, so that the drive can reach the desired end position fully. When the end position is reached, the movement counter is reset.

Reference movement after initialisation

The aim of the reference movement after a download or recovered bus voltage is to have an exact starting position for subsequent position movements.



Note: The reference movement after initialisation is always carried out, even if the "General reference movement" function is disabled.

The reference movement is triggered by an absolute positioning command. These are, for example, the receipt of a value on the "Manual height position" or "Automatic height position" objects, retrieval of scenes or pre-set values, or if an absolute position is assumed in the event of a weather alarm, alarm or lock. If after initialisation the "Manual movement object" object receives a value that moves the blind/roller shutter into the top end position, then the actuator automatically assesses this movement as a reference movement.

In general, the reference movement after initialisation is towards the top end position. If you enabled transmission of the status messages "Height status" and/or "Slat status" (active status feedback object), the current status is automatically transmitted via this object.

Reference movement in the event of movement range limitation



Caution!

Blinds/roller shutters could be damaged. The blinds/roller shutter may move beyond the limits of the movement range into windows that may be open. Pay attention therefore to where you want the reference movement to go.

A reference movement also takes place after initialisation even if the "Limit movement range" function is active. The blinds/roller shutter may move beyond the limits of the movement range into windows that may be open. Pay attention therefore to where you want the reference movement to go. In general, the reference movement after initialisation is towards the top end position. Only when the "Reference position" is set to "down" does a reference movement take place towards the lower end position. In the case of a reference movement, the "Movement range limit status feedback" object receives the value "0". The blind/roller shutter only moves in the travel range after the reference movement has completed.

Parameter settings in the ETS:

Set the following parameters for this function in the ETS:

Tab	Parameter
General	General reference movement
X: Blind or X: Roller shutter	Calibration
X: Calibration	Reference movement after
	number of movements until a reference movement is executed (1-20)
	Reference movement delay time via object in seconds
	Position after reference movement via object
	Height position after reference movement in %
	(for blind) slat position after reference movement in %
	Reference position
	Automatic calibration

Communication objects

If the "General reference movement" parameter is enabled in the "General" tab, the "Trigger reference movement" object appears.

Function	Object name	Type	Prio	Flags	Behaviour
Calibration	Trigger reference movement	1 bit	Low	WC	Receive

● **Advanced functions: Disable function for manual operating options**

You can control the connected drives using the communication objects for manual operation or by automatic control. There are two manual operation options available:

- Manually move height position and slat opening angle with up/down/step/stop commands
- Move height position and slat opening angle using absolute position commands

Disable manual operation

If you want to disable manual operation for a time, then you can activate a disable function for every output channel.

Tab	Parameter
X: Blind or X: Roller shutter	Manual lock

Depending on how it is set, manual operation is either enabled or disabled when it receives a new telegram value.

- "Manual lock" = on object value "0"
If "Manual lock" = "0": manual operation disabled (manual lock active)
If "Manual lock" = "1": manual operation enabled (manual lock inactive)
- "Manual lock" = on object value "1"
If "Manual lock" = "0": manual operation enabled (manual lock inactive)
If "Manual lock" = "1": manual operation disabled (manual lock active)

Alarm functions or other higher-level functions (e.g., wind alarm, rain alarm) also disable drive operation (see the section "Higher-level functions").

Communication objects

If you set "Manual lock" to the value "on object value 0" or "on object value 1", then the communication object "Manual lock" appears.

Function	Object name	Type	Prio	Flags	Behaviour
Channel X	Manual lock	1 bit	Low	WC	Receive

● **Advanced functions: Preset function**

The preset function allows you to save up to four height positions and slat opening angles (for blind drives) per blind or roller shutter channel and to activate these preset positions later by telegram. You can save current height positions as preset positions by telegram control. The difference between this function and the scene function is in terms of the data format of the allocated communication objects. In the case of the preset function, all communication objects are 1-bit objects.

You can activate the preset function as an alternative to the automatic function.

Activating the preset function

You can activate the preset function for each channel individually:

Tab	Parameter
X: Blind	Automatic control/Presets
X: Roller shutter	

After you have activated the function, the "X: Presets" tab opens. Here you can specify the four preset positions. You can change these positions later during operation using telegrams.

Retrieving preset positions

You can retrieve the preset positions with the communication objects "Preset 1/2" or "Preset 3/4". Following receipt of a telegram on either of the two objects, the drive moves into the saved pre-set position.

- "Retrieve preset 1/2" = "0": Preset position 1 is activated
- "Retrieve preset 1/2" = "1": Preset position 2 is activated
- "Retrieve preset 3/4" = "0": Preset position 3 is activated
- "Retrieve preset 3/4" = "1": Preset position 4 is activated

If a reference movement is necessary before moving into the preset position, the reference movement is carried out first and then the drive moves into the requested preset position.

Saving a preset position

You can replace the preset positions during operation with the communication objects "Preset 1/2" or "Preset 3/4".

Following receipt of a telegram on either of the two objects, the current position of the drive is saved as the new preset position.

- "Set preset 1/2" = "0": Saves current position as preset position 1
- "Set preset 1/2" = "1": Saves current position as preset position 2
- "Set preset 3/4" = "0": Saves current position as preset position 3
- "Set preset 3/4" = "1": Saves current position as preset position 4

If you enabled the parameter "Replace preset values in the actuator on download", then the preset values saved in the device are replaced with your default values on download. If you don't want to replace the values in the device, then you must disable this parameter.

Application example 1

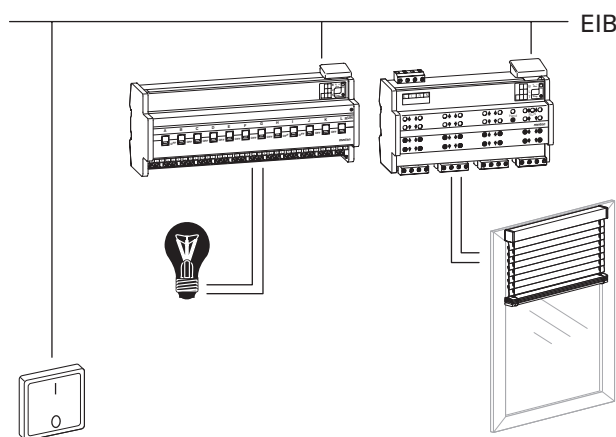

The preset function allows you, for example, to switch on the lighting and move the roller shutter at the same time by pressing one push-button. If you enter the value 0 % (roller shutter open) for preset function 1 and the value 100 % (roller shutter closed) for preset value 2, then pressing one push-button gives you the following control:

Push-button action to ON => telegram value "1" => light ON and retrieve preset position 2 = close roller shutter:

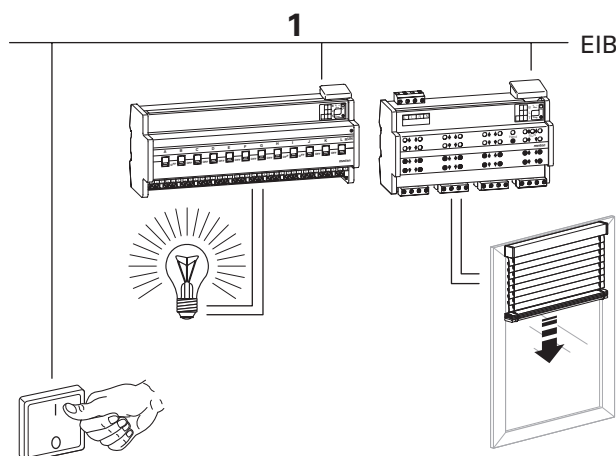

Blind 5700/1.0

Push-button action to OFF=> telegram value "0" => light OFF and retrieve preset position 1 = open roller shutter:

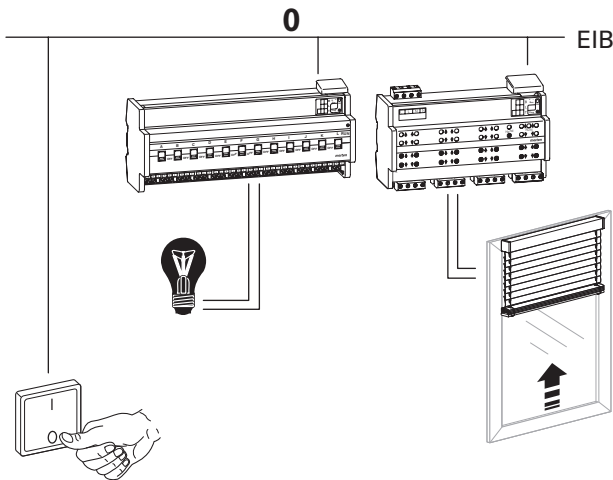

In this case, due to the fact that the roller shutter requires a certain running time to open, the light needs to be switched off with a switch-off delay so that it doesn't suddenly become dark prematurely.

Application example 2

You can also use a 1-bit light sensor to retrieve a preset. The following devices can be used as a light sensor: INSTABUS-ARGUS 220 Connect Art. No. 6315., light-sensitive switch REG-S/DS1 Art. No. 670601, weather station REG-K/4-gang Art. No. 682991.

Parameter settings in the ETS:

Set the following parameters for this function in the ETS:

Tab	Parameter
X: Blind or X: Roller shutter	Automatic control/Presets
X: Presets	Replace preset values in the actuator on download
	Preset 1 height pos. in %
	Preset 1 slat pos. in %
	Preset 2 height pos. in %
	Preset 2 slat pos. in %
	Preset 3 height pos. in %
	Preset 3 slat pos. in %
	Preset 4 height pos. in %
Preset 4 slat pos. in %	

Communication objects

Use the following objects to retrieve the preset functions:

Function	Object name	Type	Prio	Flags	Behaviour
Channel X	Retrieve preset 1/2	1 bit	Low	WC	Receive
Channel X	Retrieve preset 3/4	1 bit	Low	WC	Receive
Channel X	Set preset 1/2	1 bit	Low	WC	Receive
Channel X	Set preset 3/4	1 bit	Low	WC	Receive

● **Advanced functions: Scene function**

If you want to change various room functions at the same time using a bus telegram, then the scene function is ideal. Retrieving a scene allows you, for example, to dim the room lighting to a desired value, move the blinds into a desired position and turn the slats, switch heating control to daytime operation and switch on the power to the socket-outlets in a room. Due to the fact that these functions can have different telegram formats and moreover, the telegram values have different meanings (e.g., for lighting value "0" means OFF and for blinds OPEN), without the scene function you would have to send a separate telegram to each actuator to achieve the same result.

The scene function allows you to integrate the blind actuator into scene control. There are memory slots for up to five different scene values for each output channel. Each of these scene memory slots can be assigned one of 64 possible scene numbers (scene numbers 0 to 63 correspond to telegram values 0 to 63). You can save height positions, and for blinds also slat opening angles, as scene values. When the actuator receives a telegram that retrieves a scene number, the drive is moved into the saved position and the slats are turned. The scene numbers that you save on commissioning can be replaced later by users if they want.

Telegram format

Telegrams for the scene function have the data format L X D D D D D D.

L: Learn bit

X: is not used

DDDDDD: retrieved scene number

If the learn bit in a telegram has the value "0", the position values saved for this scene number are retrieved and engaged.

If the learn bit has the value "1", then the current drive and slat positions are saved as new position values for the scene number.

Examples:

- Telegram value 2
Binary 0000 0010
Hexadecimal 02
Retrieve scene number 2
- Telegram value 45
Binary 0010 1101
Hexadecimal 2D
Retrieve scene number 45
- Telegram value 173
Binary 1010 1101
Hexadecimal AD
Learn scene number 45
- Telegram value 190
Binary 1011 1110
Hexadecimal BE
Learn scene number 62

Activating the scene function

In order to be able to use the scene function for the individual channels, you first have to enable the function for the device once:

Tab	Parameter
General	Scenes general

After you enable the function, the communication object "Scene object" appears. This object receives the scene telegrams.

Now you can activate the function for each channel individually:

Tab	Parameter
X: Blind X: Roller shutter	Scenes

After you enable the "Scenes" parameter, the "X: Scenes" tab appears. Here you can assign the scene position. You can activate each of the scene memory slots independently of each other.

Parameter settings in the ETS:

Set the following parameters for this function in the ETS:

Tab	Parameter
General	Scenes general
X: Blind X: Roller shutter	Scenes
X: Scenes	Replace scene values in the actuator on download
	Scene 1
	Scene 1: Scene number (0-63)
	Scene 1: Height pos. in %
	Scene 1: Slat pos. in % <i>(only for blind)</i>
	Scene 2
	Scene 2: Scene number (0-63)
	Scene 2: Height pos. in %
	Scene 2: Slat pos. in % <i>(only for blind)</i>
	Scene 3
	Scene 3: Scene number (0-63)
	Scene 3: Height pos. in %
	Scene 3: Slat pos. in % <i>(only for blind)</i>
	Scene 4
	Scene 4: Scene number (0-63)
	Scene 4: Height pos. in %
	Scene 4: Slat pos. in % <i>(only for blind)</i>
	Scene 5
	Scene 5: Scene number (0-63)
	Scene 5: Height pos. in %
	Scene 5: Slat pos. in % <i>(only for blind)</i>

Retrieving and saving a scene position

The "Scene object" object allows you to retrieve scene positions. When a scene telegram is received, the blind actuator evaluates the scene number sent.

If a reference movement is necessary before moving into the scene position, the reference movement is carried out first and then the drive moves into the requested scene position.

If the "Scene object" object receives a scene telegram with learn bit "1", then the current position, and in the case of blinds the current slat position, is saved as the new scene value in all those scene memory slots allocated the scene number received.



Note: If a scene number has been allocated to more than one scene within a channel, then the first scene that has this scene number and is found will be activated (only this scene number). Or it will be saved in the memory. To avoid this, you should allocate different scene numbers to every scene within a channel.

Example:

– **Output channel 1**

Scene 1 activated to scene number 13
 (Scene 1 Height position = 50 %,
 Scene 1 Slat position = 75 %,
 Scene 2 activated to scene number 7
 (Scene 2 Height position = 0 %,
 Scene 2 Slat position = 0 %,
 Scene 3, 4, 5 deactivated

– **Output channel 5**

Scene 1 activated to scene number 7
 (Scene 1 Height position = 100 %,
 Scene 1 Slat position = 0 %,
 Scene 3 activated to scene number 21
 (Scene 3 Height position = 50 %,
 Scene 3 Slat position = 50 %,
 Scene 2, 4, 5 deactivated

"Scene object" object receives "Retrieve scene number 13" telegram:

- Output channel 1 moves into position 50 % height, 75 % slat
- Output channel 5 does not respond

"Scene object" object receives "Retrieve scene number 1" telegram:

- Actuator does not respond because scene number 1 is not assigned.

"Scene object" object receives "Retrieve scene number 7" telegram

- Output channel 1 moves into position 0 % height, 0 % slat
- Output channel 5 moves into position 100 % height, 0 % slat

"Scene object" object receives "Retrieve scene number 21" telegram

- Output channel 1 does not respond
- Output channel 5 moves into position 50 % height, 50 % slat

Drives are moved into the following positions either manually or automatically:

- Output channel 1: Height position = 30 %, Slat position = 70 %
- Output channel 5: Height position = 20 %, Slat position = 10 %

The "Scene object" object now receives a learning telegram for scene number 13

- Output channel 1: Scene 1 Height position = 30 %, Scene 1 Slat position = 70 %
- Output channel 5 does not respond

"Scene object" object receives "Retrieve scene number 13" telegram:

- Output channel 1 moves into position 30 % height, 70 % slat
- Output channel 5 does not respond

Note the difference with the first retrieval of scene number 13!

If you enabled the parameter "Replace scene values in the actuator on download", then the scene values saved in the device are replaced with your default values on download. If you don't want to replace the values in the device, then you must disable this parameter.

Extension function for scenes

This function allows you to activate or re-program the scene values for scene numbers 0–3 also using 1-bit telegrams. Activate the extension function for the device:

Tab	Parameter
General	Extension scenes

After you enable this function, two communication objects appear to activate a scene number:

- "Retrieve scene 1/2" = "0": Scene number 0 is activated
- "Retrieve scene 1/2" = "1": Scene number 1 is activated
- "Retrieve scene 3/4" = "0": Scene number 2 is activated
- "Retrieve scene 3/4" = "1": Scene number 3 is activated

Two communication objects to set a scene number also appear:

- "Set scene 1/2" = "0": Scene number 0 is programmed
- "Set scene 1/2" = "1": Scene number 1 is programmed
- "Set scene 3/4" = "0": Scene number 2 is programmed
- "Set scene 3/4" = "1": Scene number 3 is programmed



Note: The actions correspond to a normal retrieval or learn command for scene numbers 0, 1, 2, or 3 or using the "Scene object" object. The extension function is not available for scene numbers 4 to 63. You can only address these scene numbers using the "Scene object" object.

By using this extension function for scenes, you can also avail of a preset function (retrieving saved position values using 1-bit telegrams) if you want to use automatic control instead of the actual preset function. If you use the preset function and the extension function for scenes together, you have up to eight different positions available for each channel, which you can retrieve using 1-bit telegrams.

Communication objects

Use the following objects to retrieve the preset functions:

Function	Object name	Type	Prio	Flags	Behaviour
Scene extension	Retrieve scene 1/2	1 bit	Low	WC	Receive
Scene extension	Retrieve scene 3/4	1 bit	Low	WC	Receive
Scene extension	Set scene 1/2	1 bit	Low	WC	Receive
Scene extension	Set scene 3/4	1 bit	Low	WC	Receive
Scenes	Scene object	1 byte	Low	WC	Receive

Higher-level functions: General information

You can use four higher-level functions with the blind actuator:

- Weather alarm
- Alarm function
- Disable function
- Limit travel range

Higher-level functions are executed before the basic function and advanced functions.

You can prioritise the higher-level functions among each other as you wish with the following parameter:

Tab	Parameter
General	Priority sequence of higher-level functions

A higher-level function only becomes active if there is no other higher-level function active at the same time. If a higher-level function has been reset and there is another higher-level function of lower priority active at the same time, then the actions of the function of lower priority are carried out.

Higher-level functions: Weather alarm

The weather alarm functions allow you to protect the blinds or roller shutters from weather damage such as wind, rain and frost.. If an alarm is triggered for one of these three weather events, the drives move into a safe position and stay there until the event has passed.

Enabling the weather alarm function

Enable the weather alarm function for the blind actuator as a higher-level function:

Tab	Parameter
General	General weather alarm function

Once you have enabled the function, the new "General weather alarm" tab appears. Here you can configure the alarm function in detail for three wind alarms, one rain alarm and one frost protection alarm.

You can enable and disable the individual alarm functions separately. For each function you enable, a communication object appears through which the sensor signals are received.

Cyclical monitoring of sensor signals

The signals of the active weather sensors can be monitored cyclically. The device then expects a telegram from the sensor in question within the set cycle time. If it doesn't receive this telegram within the monitoring period, the associated weather alarm is still triggered for security reasons (if for example the sensor or the cable connection between the sensor and the blind actuator is defective and no signalling takes place in the event of a real alarm).

First define the time basis for the monitoring time:

Tab	Parameter
General weather alarm	Time basis for monitoring time of weather alarms

Now you can set the relevant monitoring time for each active sensor by specifying a factor:

Tab	Parameter
General weather alarm	Wind alarm no. 1
	<i>(if wind alarm no. 1 is enabled)</i> Factor for wind alarm no. 1 monitoring time
	Wind alarm no. 2
	<i>(if wind alarm no. 2 is enabled)</i> Factor for wind alarm no. 2 monitoring time
	Wind alarm no. 3
	<i>(if wind alarm no. 3 is enabled)</i> Factor for wind alarm no. 3 monitoring time
	Rain alarm
	<i>(if rain alarm enabled)</i> Factor for rain alarm monitoring time
	Frost alarm
	<i>(if frost alarm enabled)</i> Factor for frost alarm monitoring time

The monitoring time is calculated by multiplying the time basis by the factor. If you have disabled the value of a factor, then cyclical measured value monitoring will not take place for this sensor value. In this case 1-bit telegrams trigger the alarm.

Weather alarm priorities

You can prioritise the weather alarms as you wish.

Tab	Parameter
General weather alarm	Priority sequence of weather alarms

This prioritisation applies for all blind and roller-shutter channels for which you have enabled the weather protection function. Responses to a weather alarm only become active if there is no other higher-level weather alarm active at the same time. If a weather alarm is reset and there is another lower-priority weather alarm active at the same time, then the responses of the lower-priority alarm are carried out.

Response of the individual drives in the event of a weather alarm

After you have prioritised the weather alarm functions, you can specify the behaviour of the drive in the event of a weather alarm for each output channel. First you must enable the weather alarm function for each output channel:

Tab	Parameter
X: Blind	Weather alarm
X: Roller shutter	

When you have enabled the weather alarm function for an output channel, a new tab appears: "X: Weather alarm"

First select how you want the drive to respond to an active weather alarm. To protect against damage in the event of high wind speeds, you can individually assign each channel to one of the three wind sensor categories, 1, 2 or 3. Alternatively, you can choose to connect the three signals logically with the OR and AND operators.

Tab	Parameter
X: Weather alarm	Responds to wind alarm no.
	Response to wind alarms
	Response to rain alarm
	Response to frost alarm

If a wind alarm becomes active, the drive has one of the following responses depending on its settings:

- No response: The drive remains in its current position.
- Up: The drive moves into the top end position.
- Down: The drive moves into the lower end position.
- Move to position: The drive moves into the specified safety position.

When the drive has responded accordingly, it remains in this position and cannot be operated as long as the weather alarm is active. Only when a higher-level function becomes active will the response defined for this function be carried out.

If you want the drive to move into a special safety position, you can define this position using the following parameters:

Tab	Parameter
X: Weather alarm	Height position on weather alarm in %
	Slat position on weather alarm in %

This safety position applies for all three weather alarms if you selected the "Move to position" parameter value as the response to a weather alarm.

Drive behaviour after weather alarm ends

When the sensor values of the weather sensors return to within the normal measurement range, the weather alarms are deactivated again. You can specify how you want the drive to respond when the weather alarm ceases to be active.

Tab	Parameter
X: Weather alarm	Behaviour on end of all weather alarm functions

The drive then carries out the following functions:

- No response: The drive remains in its current position.
- Up: The drive moves into the top end position.
- Down: The drive moves into the lower end position.
- Move into position prior to weather alarm: The drive returns to the same position it was in before the weather alarm.
- Assume current automatic position: This setting only makes sense if the automatic function is active. The drive moves into the last requested automatic position.

Communication objects

The following communication objects are available:

Function	Object name	Type	Prio	Flags	Behaviour
Weather alarm	Wind alarm 1	1 bit	Low	WC	Receive
Weather alarm	Wind alarm 2	1 bit	Low	WC	Receive
Weather alarm	Wind alarm 3	1 bit	Low	WC	Receive
Weather alarm	Rain alarm	1 bit	Low	WC	Receive
Weather alarm	Frost alarm	1 bit	Low	WC	Receive

Higher-level functions: Alarm function

In the event of an alarm situation, the drive can be moved into a specified alarm position. When the drive reaches the alarm position, further operation is disabled. Now only a higher-level function of higher priority can move the drive into another position. You can activate the alarm function for each output channel individually:

Tab	Parameter
X: Blind	Alarm function
X: Roller shutter	

After you activate the alarm function, the communication object "Alarm object" appears for this channel. This object allows you to switch the function on and off.

You can make the other function settings in the additional "X: Alarm function" tab.

First select the object value that you want to switch on the alarm function:

Tab	Parameter
X: Alarm function	Alarm

Values to be set:

- For object value "1": Object value "1" switches the alarm function on. If the object value "0" is received, the alarm function is switched off again.
- For object value "0": Object value "0" switches the alarm function on. A telegram with the object value "1" deactivates the function again.

Drive behaviour when alarm function is activated

Here you specify how you want the blind actuator to behave when the alarm function is enabled:

Tab	Parameter
X: Alarm function	Behaviour on alarm start

Values to be set:

- No response: The drive remains in its current position.
- Up: The drive moves into the top end position.
- Down: The drive moves into the lower end position.
- Move to position: The drive moves into the specified safety position.

After the drive has carried out the desired action, it remains in this position and cannot be operated as long as the alarm function is active. Only when a higher-level function becomes active will the response defined for this function be carried out.

You can define a special safety position for the alarm function:

Tab	Parameter
X: Alarm function	Height position on alarm start in %
	Slat position on alarm start in %

The drive moves into this safety position if you selected the "Move into position" parameter value as the behaviour when the alarm function begins.

Drive behaviour when alarm function has finished

When a new object value has switched the alarm function off, you can operate the drive as normal again. If you want the drive to carry out an automatic action when the alarm function ends, you can define this action using the following parameter:

Tab	Parameter
X: Alarm function	Behaviour on alarm end

Values to be set:

- No response: The drive remains in its current position.
- Up: The drive moves into the top end position.
- Down: The drive moves into the lower end position.
- Move into position prior to alarm: The drive returns to the same position it was in before the alarm.
- Assume current automatic position: This setting only makes sense if the automatic function is active. The drive moves into the last requested automatic position.

Alarm function on bus voltage recovery

This parameter allows you to specify how you want the alarm function to respond when bus voltage is recovered:

Tab	Parameter
X: Alarm function	Alarm status on bus voltage recovery

Values to be set:

- Inactive: After bus voltage has been recovered, the alarm function is deactivated, regardless of its status prior to bus voltage failure.
- Active: The alarm function is activated when bus voltage has recovered. The output relay responds in line with your settings for behaviour following bus voltage recovery (see the section "Operating behaviour on failure and recovery of supply voltage").
- As before bus voltage failure: The alarm function resumes the status it had before bus voltage failure. Your settings regarding behaviour following bus voltage recovery determine the output relay's response in this case also.

Communication objects

The following communication objects are available:

Function	Object name	Type	Prio	Flags	Behaviour
Channel X	Alarm object	1 bit	Low	WC	Receive

● **Higher-level functions: Disable function**

In the event of a special operating status, the drive can move into a specified disable position. When the drive has reached the disable position, operation is no longer possible. Now only a higher-level function of higher priority can move the drive into another position. You can activate the disable function for each output channel individually:

Tab	Parameter
X: Blind	Disable function
X: Roller shutter	

After you activate the disable function, the "Disable object" communication object appears for this channel. This object allows you to switch the function on and off.

You can make the other function settings in the additional "X: Disable function" tab.

First select the object value that you want to switch on the disable function:

Tab	Parameter
X: Disable function	Lock

Values to be set:

- For object value "1": Object value "1" switches the disable function on. If the object value "0" is received, the disable function is switched off again.
- For object value "0": Object value "0" switches the disable function on. A telegram with the object value "1" deactivates the function again.

Drive behaviour when disable function is activated

Here you specify how you want the blind actuator to behave when the disable function is enabled::

Tab	Parameter
X: Disable function	Behaviour on lock start

Values to be set:

- No response: The drive remains in its current position.
- Up: The drive moves into the top end position.
- Down: The drive moves into the lower end position.
- Move to position: The drive moves into the specified safety position.

After the drive has carried out the desired action, it remains in this position and cannot be operated as long as the disable function is active. Only when a higher-level function becomes active will the response defined for this function be carried out.

Blind 5700/1.0

You can define a special safety position for the disable function:

Tab	Parameter
X: Disable function	Height position on lock start in %
	Slat position on lock start in %

The drive moves into this safety position if you selected the "Move into position" parameter value as the behaviour when the disable function begins.

Drive behaviour when disable function has finished

When a new object value has switched the disable function off, you can operate the drive as normal again. If you want the drive to carry out an automatic action when the disable function ends, you can define this action using the following parameter:

Tab	Parameter
X: Disable function	Behaviour on lock end

Values to be set:

- No response: The drive remains in its current position.
- Up: The drive moves into the top end position.
- Down: The drive moves into the lower end position.
- Move into position prior to disable: The drive returns to the same position it was in before the disable function.
- Assume current automatic position: This setting only makes sense if the automatic function is active. The drive moves into the last requested automatic position.

Disable function on bus voltage recovery

This parameter allows you to specify how you want the disable function to respond when bus voltage fails:

Tab	Parameter
X: Disable function	Behaviour of disable function on bus voltage recovery

Values to be set:

- Inactive: After bus voltage has been recovered, the disable function is deactivated, regardless of its status prior to bus voltage failure.
- Active: The disable function is activated when bus voltage has been recovered. The output relay responds in line with your settings for behaviour following bus voltage recovery (see the section "Operating behaviour on failure and recovery of supply voltage").

- As before bus voltage failure: The disable function resumes the status it had before bus voltage failure. Your settings regarding behaviour following bus voltage recovery determine the output relay's response in this case also.

Communication objects

The following communication objects are available:

Function	Object name	Type	Prio	Flags	Behaviour
Channel X	Disable object	1 bit	Low	WC	Receive

● **Higher-level functions: Limitation of the movement range**

For certain applications, e.g. open pivot-hung windows, it can be helpful or necessary to limit the possible movement range of a drive temporarily or permanently. If the movement range has been limited, then during manual operation, automatic functions, scene retrievals or presets, the drive can only move within the defined limits. The limit also applies for movement commands from functions of lower priority. Only a higher-level function of higher priority can move the drive into another position beyond the limit.

You can activate the movement range limitation for each output channel individually:

Tab	Parameter
X: Blind X: Roller shutter	Movement range limits

After you have activated the movement range limits, the additional "X: Movement range limits" tab appears:

Tab	Parameter
X: Movement range limits	Limit movement range

Values to be set:

- Immediately after bus voltage recovery: The function becomes active immediately after bus voltage recovery or a download. The drive can only move between the limit values. Only a function of higher priority can move the drive into a position beyond the limit.
- For object value "1": Object value "1" switches the limit on. If the object value "0" is received, the entire movement range is enabled again.
- For object value "0": Object value "0" switches the limit on. A telegram with the object value "1" deactivates the limit again.

When activated by an object value, an additional communication object "Activate movement limits" appears for this channel. This object allows you to switch the limit on and off.

You can set the limits of the movement range using additional parameters:

Tab	Parameter
X: Movement range limits	upper limit value in %
	lower limit value in %

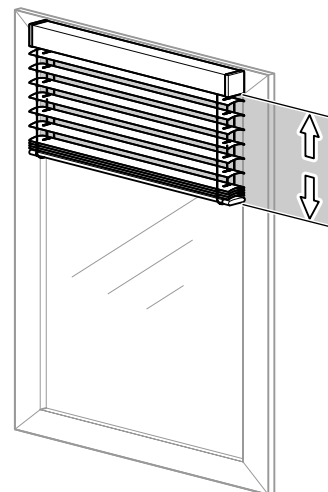

When the limit function is active, the drive only moves between the limit values. The limit applies for all movement commands from manual operation, automatic functions, scenes, presets and for movements from functions of lower priority.

If the drive is outside the limits when the movement range limitation is activated, then it is automatically moved to the nearest limit and remains there.

i Note: Remember to set the lower limit value higher than the top limit value because otherwise the drive can't move.

When a drive reaches its movement range limits, this is reported by a status object on the bus. Dependent functions, for example opening a window, can now be carried out. The next section on "Status responses" has more information on this.

Reference movement after initialisation

⚠ Caution! Blinds/roller shutters could be damaged. The blinds/roller shutter may move beyond the movement range limits into windows that may be open. Pay attention therefore to where you want the reference movement to go.

After a download or bus voltage recovery, a reference movement takes place following initialisation, even if the "General reference movement" function is disabled. The blinds/roller shutter may move beyond the limits of the movement range into windows that may be open.

Pay attention therefore to where you want the reference movement to go. In general, the reference movement after initialisation is towards the top end position. Only when the "Reference position" is set to "down" does a reference movement take place towards the lower end position.

In the case of a reference movement, the "Movement range limit status feedback" object receives the value

"0". The blind/roller shutter only moves in the travel range after the reference movement has completed.

Drive behaviour after movement limitation ends

If object values are responsible for limiting the movement range and a new object value disables the limitation, then you can operate the drive as normal again. If you want the drive to carry out an automatic action in this case, you can define this action using the following parameter:

Tab	Parameter
X: Movement range limits	Behaviour at end of movement limitation

Values to be set:

- No response: The drive remains in its current position.
- Up: The drive moves into the top end position.
- Down: The drive moves into the lower end position.
- Move into position prior to movement limitation: The drive returns to the same position it was in before movement limitation.
- Assume current automatic position: This setting only makes sense if the automatic function is active. The drive moves into the last requested automatic position.

Communication objects

The following communication objects are available:

Function	Object name	Type	Prio	Flags	Behaviour
Channel X	Activate movement limits	1 bit	Low	WC	Receive

● **Status messages/status feedback**

The software application provides you with numerous options to report the current device status and the status of output channels via communication objects. Depending on these status messages, you can trigger certain control processes or enable and disable functions in the system.

So for example, opening a window is permitted if a blind drive reports that it has reached the height position within a movement range limitation. The window status in turn can be used to deactivate an active movement range limitation.

In addition, status messages are also suitable for displaying current operating statuses by means of visualisation software.

The status messages of the output channels are made available through communication objects. You can set the transmission characteristics of these status objects to one of the following values using parameters:

- disabled
The status object is not active.
- active status feedback object
When the status changes, the new status is automatically transmitted.
- passive status object
The status object does not transmit its values. But the current status is available and can be read out by other bus devices.

Transmission behaviour of the status messages in time

You can prioritise the interval between two status telegrams for the device. This setting applies for the transmission behaviour of all status messages.

Tab	Parameter
General	Minimum interval between status messages

If there is only one pending transmission job, then the message is sent immediately. If there are several status messages pending, then the first one is sent immediately and the remainder are staggered according to the delay time specified in the "Minimum interval between status messages" parameter.

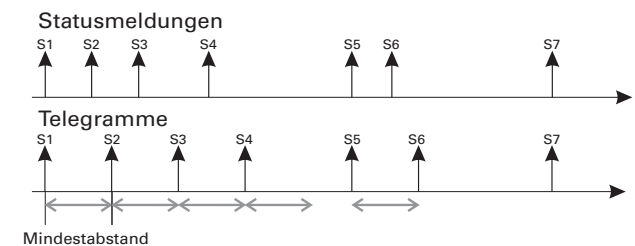

Blind 5700/1.0

If you want to activate the status messages for an output channel, then you have to enable the "Status messages" parameter:

Tab	Parameter
X: Blind X: Roller shutter	Status messages

A new tab "X: Status messages" then appears for this output channel. Here you make settings for the possible status messages.

Height status

The current position of the drive is available as a value between 0 –100 %. The associated status objects change name depending on whether the status is to be transmitted (Height status feedback) or read out (Height status).

Tab	Parameter
X: Status messages	Height status

The height status object is only updated when the drive has reached a fixed position after a movement.

Slat status

The current angle of rotation of the blind slats is available as a value between 0 –100 %. The associated status objects change name depending on whether the status is to be transmitted (Slat status feedback) or read out (Slat status).

Tab	Parameter
X: Status messages	Slat status

The slat status object is only updated when the drive has reached a fixed position after a movement.

Automatic status

The status message of the automatic function takes place via the "Automatic lock" object of the output channels (see the section "Automatic control"). This is a bidirectional object. In addition to its status function, it also serves to enable and disable the automatic function directly using bus telegrams.

If you want to display an activation and lock of the automatic function via operating telegrams as a status function, then set the "Automatic status" to the desired value:

Tab	Parameter
X: Status messages	Automatic status

The current object value of the "Automatic lock" object is simultaneously the status value.

Disable message status

There are two types of disable messages you can activate as the status message: a drive lock or a movement range limitation.

Tab	Parameter
X: Status messages	Disable message type

Disable message type = Drive lock

A drive lock is triggered by the higher-level functions weather alarm, alarm function and disable function.

Tab	Parameter
X: Status messages	Drive lock status

If one of the higher-level functions is active and the drive has reached its defined safety position, the status object receives the value "1". When the drive is enabled again, the object value of the status message changes to "0".

Disable message type = Movement range limit

If you are using the higher-level function movement range limitation and other control functions depend on whether the drive has reached its limit if movement range limitation is active, then you can report this using this status type:

Tab	Parameter
X: Status messages	Movement range limit status

The value of the status object receives the object value "1" if movement range limitation is active and the drive has reached one of the specified limits.

- If, when movement range limitation is activated, the drive is already within the specified limits, then the status object receives the object value "1" immediately.
- If a function of higher priority causes the drive to leave the movement range or if the limitation is cancelled, then object value switches to "0".

Communication objects

The following communication objects are available:

Function	Object name	Type	Prio	Flags	Behaviour
Channel X	Height status feedback	1 bit	Low	CRT	Transmit/Read out
Channel X	Height status	1 bit	Low	CR	Read out
Channel X	Slat status feedback	1 bit	Low	CRT	Transmit/Read out
Channel X	Slat status	1 bit	Low	CR	Read out
Channel X	Drive lock status feedback	1 bit	Low	CRT	Transmit/Read out
Channel X	Drive lock status	1 bit	Low	CR	Read out
Channel X	Movement range limit status feedback	1 bit	Low	CRT	Transmit/Read out
Channel X	Movement range limit status	1 bit	Low	CR	Read out
Channel X	Automatic lock	1 bit	Low	CRW T	Transmit/Receive/Read out

● **Manual operation and status displays**

On the front of the device there is a channel key and a yellow LED for each channel to display the operating statuses of the channel (channel status LED).

In addition to the channel keys for the output channels and the channel status LED, the device also has a toggle switch and a red LED labelled "Manual" (manual operation LED). The toggle switch allows you to activate and deactivate manual operation. Another green operation LED labelled "RUN" (RUN LED) indicates that the device is ready for operation.

The programming key for programming the physical address of the device and an associated red programming LED are located under the cover of the bus connection.



Note: For more information see the chapter "Operation".

After the mains or bus voltage has been connected, you can move the connected drives using the operating keys, if you have activated manual operation. The status LEDs allocated to the channels indicates the current switching status.

Setting manual operation

You can set the blind actuator in such a way that it can be operated using the channel keys:

Tab	Parameter
General	Manual operation type
	Manual operation activation
	Time-dependent reset of manual operation
	<i>(if "Time-dependent reset of manual operation" is enabled):</i> Time in minutes when hand operation will be automatically reset (5-255)

If "Manual operation type" = "Manual operation only" and you press the manual key, the device is in pure manual operation (manual LED lights up). It does not evaluate any bus telegrams. The connected drives can only be moved manually using the channel keys. Due to the fact that bus telegrams are suppressed, the drives can also be moved if higher-level functions are active.



Caution!

When operating blinds or roller shutters in "Manual operation only" using the channel keys, safety functions such as weather alarm position, alarm position, disable position or travel range no longer work. To prevent damage to the blind/roller shutter, you should therefore be very careful when operating manually!

If the "Manual operation type" parameter has the value "Bus and manual operation", you can operate the connected drives manually with the channel keys and with bus telegrams. This has the same effect as receiving a bus telegram. If however during this mode one of the higher-level functions (weather alarm, alarm function, disable function or limit travel range) is active, then manual operation is disabled.

First select the desired operation mode for manual operation, as described above. Then you can select the settings for enabling manual operation:

- disabled
Switching to manual operation using the manual key is not possible.
- enabled
Switching to manual operation using the manual key is possible. The manual LED indicates the current manual operation mode.
- enabled with status message
Switching to manual operation using the manual key is possible. The manual LED indicates the current manual operation mode. When you switch to manual operation mode, a telegram with the value "1" is sent via the "Manual operation status" object. When manual operation is reset, a telegram with the value "0" is sent.
- Enable via object
The "Enable manual operation" object allows you to enable and disable the switching option for manual operation. Manual operation is enabled on receipt of a telegram with the value "1" and disabled on receipt of a telegram with the value "0".
- Enable via object with status message
In addition to enabling manual operation with the "Enable manual operation" object, the "Manual operation status" object reports the switching status.



Note: To switch the blind actuator to manual operation, press the manual key before pressing a channel key.

Resetting manual operation dependent on time

You can limit the switch to manual operation on a time basis. To do this, set the "Time-dependent reset of manual operation" parameter to "enabled".

Then set the "Time for automatic reset of manual operation in minutes" parameter. When the time you specify here expires, the device automatically resets manual operation. The manual LED indicates the current operating status.

Enabling manual operation on bus voltage failure

If bus voltage fails, then you can provide users with an additional control option for the connected loads: manual operation. Mains voltage must still be present however. You can enable manual operation on bus voltage failure for each channel individually. Enable or disable the following parameter:

Tab	Parameter
X: Blind	Manual operation on bus voltage failure (mains voltage present)
X: Roller shutter	

"Manual operation on bus voltage failure" disabled

If bus voltage has failed and you press a channel key, the blind/roller shutter drive does not respond.

"Manual operation on bus voltage failure" enabled

You can continue to operate the connected drive using the channel keys in the event of bus voltage failure (press manual key). Manual operation during bus voltage failure is possible independently of the settings for manual operation activation. The status LEDs indicate the current output status. When bus voltage is recovered, manual operation is automatically reset.



Caution!

Risk of damage!

When using the channel keys to manually operate blinds or roller shutters during a bus failure, safety functions such as the weather alarm position, alarm position, disable position and travel range no longer have any effect.

To prevent damage to the blind/roller shutter, you should therefore be very careful when operating manually!

Manual operation for blind/roller shutter

When manual operation is enabled, you can move connected drives using the channel keys (see section "Operation").

The running time of the drive is preset to 2 min and the switching time to 500 ms. Please observe the specifications of the drive manufacturer.

If you press a channel key when manual operation is not active or has been temporarily disabled by a higher-level function, nothing happens.

Communication objects

The following communication objects are available:

Function	Object name	Type	Prio	Flags	Behaviour
Manual operation	Enable manual operation	1 bit	Low	CW	Receive
Manual operation	Manual operation status	1 bit	Low	CRT	Transmit/Read out

● **Behaviour after failure and recovery of supply voltage**

 **Note:** Normally, the device is connected to both bus and mains voltage. All device functions can only be fully guaranteed if the device is receiving both supply voltages correctly.

If the engine supply voltage for the loads fails or is recovered, the blind actuator itself doesn't carry out any action. Please note the following however:

 **Caution!** Switching on the engine can cause the drives to move if the output relay is switched on at the time. In order to avoid bodily injury or material damage, ensure that before switching the supply voltage on again that all connected blinds and roller shutters can move freely.

 **Note:** If only bus voltage is available, the blind actuator can generally carry out all functions, possibly with a short time delay however (e.g., switching relays, slat adjustment). Manual operation is possible.

Without bus voltage (mains voltage only), the blind actuator may only work in manual operation without bus communication. You can operate the blind or roller shutter directly using the channel keys.

If you want the blind actuator to respond in a certain way when supply voltage fails unexpectedly during operation, then you can configure failure behaviour for each channel.

Tab	Parameter
X: Blind X: Roller shutter	Failure behaviour

When you have enabled the failure behaviour for a channel, the additional tab "X: Failure behaviour" appears. Here you can set more parameters. These depend on the type of voltage failure:

- Possibility 1:
 Bus voltage failure/recovery
 Mains voltage present
- Possibility 2:
 Bus voltage present
 Mains voltage failure/recovery
- Possibility 3:
 Bus voltage failure/recovery
 Mains voltage failure/recovery

Blind 5700/1.0

The setting options in the "X: Failure behaviour" tab vary according to the type of voltage failure.

Possibility 1: Bus voltage failure/recovery, mains voltage present

Bus voltage has failed

The RUN LED is not lit when bus voltage fails. If the output channels for manual operation are enabled in the event of bus voltage failure, you can operate the connected drives using the channel keys.

Behaviour of channels for blind/roller shutters

You can set failure behaviour as follows:

Tab	Parameter
X: Failure behaviour	Behaviour on bus voltage failure (fixed pause on reverse = 300 ms)

Possible settings:

- no response
The drive remains in its current status, in other words, it doesn't move or it completes its current movement until the running times have expired.
- Stop
The drive stops immediately.
- Up
The drive moves upwards. If it was in the middle of an downwards movement, then it stops and waits the default pause on reverse time of 300 ms before beginning the upwards movement.
- Down
The drive moves downwards. If it was in the middle of an upwards movement, then it stops and waits the default pause on reverse time of 300 ms before beginning the downwards movement.



Caution!

If it is possible that your settings may result in a change of direction in the event of bus voltage failure (up or down settings), it is important to remember the pause on reverse. This is pre-set to a fixed value of 300 ms for bus voltage failure. The parameterised value for the drive is not active in this case. If the drive in use requires a longer pause on reverse (see manufacturer specifications), then you may not use the "up" or "down" settings in order to avoid damaging the drive.

When making your settings, ensure that the higher-level safety functions are not active during bus voltage failure. So that this doesn't cause damage, it makes sense to make the settings in such a way that the drive assumes a safe position during bus voltage failure.

Bus voltage is recovered

The RUN LED is lit, thus indicating that bus voltage is present again. The behaviour that you specified for bus voltage recovery is also carried out if the device receives a restart instruction (management function) through a bus.

Thirty seconds after bus voltage is once again stably present, the device starts transmitting the activated status messages of all the channels one after another. However, only those status messages that you did **not** define as passive status objects are transmitted, in other messages defined for read out only. The object value of the status objects valid at the time of transmission is always sent as the status message, even if it has changed once or several times since bus voltage has been recovered. For more information, refer to the section "Status messages".

Behaviour of channels for blind/roller shutters

After bus voltage has been recovered, all output relays are opened (all drives stop) and the pause on reverse specified by the parameters is started. Only after the pause on reverse time has expired will the behaviour that you set with the following parameter be carried out:

Tab	Parameter
X: Failure behaviour	Behaviour on bus voltage recovery

Possible values:

- Stop
The drive stays in its current idle state.
- Up
The drive moves upwards. If it was in the middle of an downwards movement, then it stops and waits the pause on reverse time before beginning the upwards movement.
- Down
The drive moves downwards. If it was in the middle of an upwards movement, then it stops and waits the pause on reverse time before beginning the downwards movement.
- Move to position
The blind moves into a position defined by you. The new parameter "Height position on bus voltage recovery in %" appears to allow you to set this position.
Set the desired height position in the possible travel range of 0 –100 %.
In the case of blind drives, the additional parameter "Slat position on bus voltage recovery in %" allows you to define the opening angle of the slats in the regulating range of 0 –100 %.

If there is no weather alarm present, the position movement begins. If there is a weather alarm present, then the device responds in line with your settings for this weather alarm, and the position movement is no longer carried out.

Behaviour of higher-level functions

In addition to the behaviour of the channels, you can also specify the behaviour of higher-level functions following bus voltage recovery.

Alarm function

Following bus voltage recovery, the alarm function of the channel responds in line with your settings. It remains either inactive (deactivated) or active, or it reverts to the status prior to bus voltage failure (see the section "Alarm function" also).

Tab	Parameter
X: Alarm function	Alarm status on bus voltage recovery

Disable function

Following bus voltage recovery, the disable function of the channel responds in line with you settings. It remains either inactive (deactivated) or active, or it reverts to the status prior to bus voltage failure (see the section "Disable function" also).

Tab	Parameter
X: Disable function	Lock status on bus voltage recovery

Possibility 2: Bus voltage present, mains voltage failure/recovery

Mains voltage has failed

The blind actuator can still carry out all functions if supplied by bus voltage only. The power supply for switching the relays, however, is provided primarily by the mains voltage. If the mains voltage fails, it can still carry out all functions, but there may be a slight time delay (e.g. switching of the relays, slat adjustment). Manual operation is possible.

You can transmit the status of the mains voltage to the to bus via a communications object. You can set the transmission behaviour of this status object with a parameter:

Tab	Parameter
General	Mains voltage status

Possible settings:

- disabled
The current status of the mains voltage is not transmitted to the bus and cannot be read out either. No communication object is available.
- active status feedback object
If it changes, the current status of the mains voltage is transmitted to the bus via the "Mains voltage status feedback" communication object. If mains voltage is present, the object value is "1", if there is no mains voltage "0".
- passive status object
You can export the current status of the mains voltage using the "Main voltage status" communication object. The object value is not sent in the case of changes.

For more information see the section "Status messages".

Mains voltage is recovered

When the mains voltage is present again, then the device is once again in normal operation and the switching processes can be carried out as normal. You can transmit the status of the mains voltage to the bus or make it available for readout. In this case the status object has the value "1".

Possibility 3: Bus and mains voltage failure/recovery

Bus and mains voltage fail

If the power supply for switching the relays fails in addition to the bus functions, the blind actuator cannot carry out any more switching actions. Status displays, the manual LED and the RUN LED all go out. Manual operation using the channel keys is no longer possible.

Behaviour of channels for blind/roller shutters

The relays remain permanently in their current switching position. The switching status of the relays can only be changed when bus voltage is recovered.

Behaviour when bus voltage fails after mains voltage failure

If the bus voltage fails after the main voltage has previously failed, then the relays remain in their current switching position permanently. The switching status of the relays can only be changed when bus voltage is recovered.

Behaviour when mains voltage fails after bus voltage failure

If the mains voltage fails after the bus voltage has previously failed, there is no additional response. The relays remain in their current switching position. The status displays, the manual LED and the RUN LED all go out.

Bus and mains voltage are recovered

The RUN LED is lit, thus indicating that bus voltage is present again. The status LEDs of the channels indicate the current output statuses. The manual LED is switched off, thus indicating that manual operation is deactivated.

The output channels behave in line with your settings following the failure of bus voltage only (see option 1).

The relays are not switched until there is enough power to do so safely.

Status messages

The device can transmit status messages again. For more information see "Behaviour after bus voltage recovery" (option 1).

Behaviour of higher-level functions

The settings and behaviour of higher-level functions correspond to those described under bus voltage recovery (option 1).

Behaviour on recovery of bus voltage without mains voltage

In this case, the device behaves as described under "Bus and mains voltage are recovered". It transmits the status of the mains voltage with the value "0".

Behaviour on recovery of mains voltage without bus voltage

If mains voltage is recovered without bus voltage, the device behaves as described under bus voltage failure with mains voltage present (option 1).

Communication objects

The following communication objects are available:

Function	Object name	Type	Prio	Flags	Behaviour
Status	Mains voltage status	1 bit	Low	CR	Send
Status	Mains voltage status feedback	1 bit	Low	CR	Transmit/Read out

● Behaviour after application download

Before the first download after commissioning, all relays are switched off (default setting). Manual operation is deactivated; the manual LED is switched off.

You can specify the download behaviour of the output channels:

Tab	Parameter
X: Blind X: Roller shutter	Failure behaviour
X: Failure behaviour (if failure behaviour enabled)	Relay status after download

Possible settings:

- no response
After a download, the relays remain in their current status.
- as for bus voltage recovery
The relays behave in line with your settings for a return of bus voltage for this channel.

If an internal error or a defective download results in a status in which the application is no longer operational, the device does not respond. The drives remain in their last position. All relays are switched off.

● Parameters and settings

This section lists all the parameters of the ETS application with their settings and default settings.

General	
Parameter	Setting
Manual operation type	Bus and manual operation Manual operation only
Manual operation activation	disabled
	enabled
	enabled with status message
	Enable via object Enable via object with status message
Time-dependent reset of manual operation	disabled
	enabled
Scenes general	disabled
	enabled
Extension scenes	disabled
	enabled
Mains voltage status	disabled
	active status feedback object
	passive status object
Minimum interval between status messages	100 ms, 200 ms , 500 ms, 1 sec, 1.5 sec, 2 sec

General	
Parameter	Setting
Priority sequence of higher-level functions	1. alarm, 2. weather alarm, 3. lock, 4. movement range
	1. alarm, 2. weather alarm, 3. movement range, 4. lock
	1. alarm, 2. lock, 3. weather alarm, 4. movement range
	1. alarm, 2. lock, 3. movement range, 4. weather alarm
	1. alarm, 2. movement range, 3. weather alarm, 4. lock
	1. alarm, 2. movement range, 3. lock, 4. weather alarm
	1. weather alarm, 2. alarm, 3. lock, 4. movement range
	1. weather alarm, 2. alarm, 3. movement range, 4. lock
	1. weather alarm, 2. lock, 3. alarm, 4. movement range
	1. weather alarm, lock, 3. movement range, 4. alarm
	1. weather alarm, 2. movement range, 3. alarm, 4. lock
	1. weather alarm, 3. movement range, 3. lock, 4. alarm
	1. lock, 2. alarm, 3. weather alarm, 4. movement range
	1. lock, 2. alarm, 3. movement range, 4. weather alarm
	1. lock, 2. weather alarm, 3. alarm, 4. movement range
	1. lock, 2. weather alarm, 3. movement range, 4. alarm
	1. lock, 2. movement range, 3. weather alarm, 4. alarm
	1. lock, 2. movement range, 3. alarm, 4. weather alarm
	1. movement range, 2. alarm, 3. weather alarm, 4. lock
	1. movement range, 2. alarm, 3. lock, 4. weather alarm
1. movement range, 2. weather alarm, 3. alarm, 4. lock	
1. movement range, 2. weather alarm, 3. lock, 4. alarm	
1. movement range, 2. lock, 3. weather alarm, 4. alarm	
1. movement range, 2. lock, 3. alarm, 4. weather alarm	
General weather alarm function	disabled enabled (=> "General weather alarm" tab)
General reference movement	disabled enabled

Channel_config_X	
Parameter	Setting
Channel X operating mode	disabled (default setting for all channels except 1)

Blind 5700/1.0

Channel_config_X	
Parameter	Setting
	Blind (default setting for channel 1) (=> "X: Blind" tab => "X: Drive" tab)
	Roller shutter (=> "X: Roller shutter" tab => "X_Drive" tab)

If weather alarm is enabled in the "General" tab:

General weather alarm	
Parameter	Setting
Time basis for monitoring time of weather alarms	1 sec, 1 min , 1 hr
Priority sequence of weather alarms	1. wind alarm, 2. rain alarm, 3. frost alarm 1. wind alarm, 2. frost alarm, 3. rain alarm 1. rain alarm, 2. wind alarm, 3. frost alarm 1. rain alarm, 2. frost alarm, 3. wind alarm 1. frost alarm, 2. wind alarm, 3. rain alarm 1. frost alarm, 2. rain alarm, 3. wind alarm
Wind alarm no. 1	disabled enabled
Factor for wind alarm no. 1 monitoring time (if wind alarm no. 1 enabled)	disabled , 1 to 255
Wind alarm no. 2	disabled enabled
Factor for wind alarm no. 2 monitoring time (if wind alarm no. 2 enabled)	disabled , 1 to 255
Wind alarm no. 3	disabled enabled
Factor for wind alarm no. 3 monitoring time (if wind alarm no. 3 enabled)	disabled , 1 to 255
Rain alarm	disabled enabled
Factor for rain alarm monitoring time (if rain alarm enabled)	disabled , 1 to 255
Frost alarm	disabled enabled
Factor for frost alarm monitoring time (if rain alarm enabled)	disabled , 1 to 255

X_Blind X_Roller shutter	
Parameter	Setting
Only for operation type "blind"	
How does the existing blind move?	downwards closed / upwards level (= blind type 1) downwards tilted / upwards level (= blind type 2) downwards closed / upwards closed (= blind type 3) downwards tilted / upwards closed (= blind type 4)
Slat working position in % (for blind type 1 and 3 - if working position)	0-100 Default settings: Blind type 1: 50% Blind type 3: 75%
What is the current slat position on downward movement in %? (for blind type 2 and 4)	0-100 Default settings: Blind type 2: 50% Blind type 4: 75%
Slat position after movement	no response Working position last slat position

"Blind" operation type / "Roller shutter" operation type

Automatic control/Presets	disabled Automatic control (=> "X_Automatic" tab) Presets (=> "X_Presets" tab)
Scenes	disabled enabled (=> "X_Scenes" tab)
Manual lock	inactive For object value "0" For object value "1"
Calibration	disabled enabled (=> "X_Calibration" tab)
Weather alarm	disabled enabled (=> "X_Weather alarm")
Alarm function	disabled enabled (=> "X_Alarm function" tab)
Disable function	disabled enabled (=> "X_Disable function" tab)
Movement range limits	disabled enabled (=> "X_Movement range limits" tab)
Failure behaviour	disabled enabled (=> "X_Failure behaviour" tab)
Status messages	disabled enabled (=> "X_Status messages" tab)
Manual operation on bus voltage failure (mains voltage present)	disabled enabled

X: Drive	
Parameter	Setting
Advanced drive parameter	enabled
	disabled
Time basis for height running time	10 ms, 100 ms
Factor for height running time (10-64000) 1 second = 1000 ms	10-64000, 1200 default setting
Shared time basis for running time supplements/dead time	10 ms , 100 ms
Factor for running time upwards supplement	disabled, 1-255, 20 default setting
Factor for dead time until upwards movement	disabled , 1-255
Factor for slat open up start-up supplement ("Blind" only)	disabled , 1-255
Factor for slat open down start-up supplement ("Blind" only)	disabled , 1-255
Time basis for slat step time ("Blind" only)	10 ms , 100 ms
Factor for slat step time (5-255) ("Blind" only)	5-255, 10 default setting
Time basis for slat running time ("Blind" only)	10 ms , 100 ms
Factor for slat running time (5-255) ("Blind" only)	5-255, 100 default setting
Pause on change for change of direction (1-255), factor * 100 ms, manufacturer data!	1-255, 5 default setting
Factor for start-up delay Factor * 10 ms	disabled , 1-255
Factor for run-out delay Factor * 10 ms	disabled , 1-255

If "Automatic control/Presets" in the "X_Blind" tab set to "Automatic control":

X: Automatic	
Parameter	Setting
Automatic lock	inactive
	For object value "0"
	For object value "1"
Response in automatic operation on receipt of a manual object value	Automatic control disabled
	Automatic control remains enabled
	Automatic control disabled temporarily
Behaviour on deactivation of automatic lock via object value (only if automatic lock enabled)	no response
	Assume current automatic position
Time basis for automatic control deactivation time (only if automatic control disabled temporarily)	1 sec, 1 min , 1 hr
Factor for automatic control deactivation time (only if automatic control disabled temporarily)	1-255, 1 default setting

If "Automatic control/Presets" in the "X_Blind" tab set to "Presets":

X: Presets	
Parameter	Setting
Replace preset values in the actuator on download	disabled
	enabled
Preset 1: Height pos. in %	0-100, 0 default setting

X: Presets	
Parameter	Setting
Preset 1: Slat pos. in %	0-100, 0 default setting
Preset 2: Height pos. in %	0-100, 0 default setting
Preset 2: Slat pos. in %	0-100, 0 default setting
Preset 3: Height pos. in %	0-100, 0 default setting
Preset 3: Slat pos. in %	0-100, 0 default setting
Preset 4: Height pos. in %	0-100, 0 default setting
Preset 4: Slat pos. in %	0-100, 0 default setting

If "Scenes" in the "X_Blind" tab is "enabled":

X: Scenes	
Parameter	Setting
Replace scene values in the actuator on download?	disabled
	enabled
Scene 1	disabled
	enabled
Scene 1: Scene number (0-63) (only if scene 1 enabled)	0-63, 0 default setting
Scene 1: Pos. height (1-64) (only if scene 1 enabled)	0-100, 0 default setting
Scene 1: Pos. height in % (blind operation only and only if scene 1 enabled)	0-100, 0 default setting
Scene 2	disabled
	enabled
Scene 2: Scene number (0-63) (only if scene 2 enabled)	0-63, 1 default setting
Scene 2: Pos. height (2-64) (only if scene 1 enabled)	0-100, 0 default setting
Scene 2: Pos. height in % (blind operation only and only if scene 2 enabled)	0-100, 0 default setting
Scene 3	disabled
	enabled
Scene 3: Scene number (0-63) (only if scene 3 enabled)	0-63, 2 default setting
Scene 3: Pos. height (3-64) (only if scene 1 enabled)	0-100, 0 default setting
Scene 3: Pos. height in % (blind operation only and only if scene 3 enabled)	0-100, 0 default setting
Scene 4	disabled
	enabled
Scene 4: Scene number (0-63) (only if scene 4 enabled)	0-63, 3 default setting
Scene 4: Pos. height (4-64) (only if scene 1 enabled)	0-100, 0 default setting
Scene 4: Pos. height in % (blind operation only and only if scene 4 enabled)	0-100, 0 default setting
Scene 5	disabled
	enabled
Scene 5: Scene number (0-63) (only if scene 5 enabled)	0-63, 4 default setting
Scene 5: Pos. height (5-64) (only if scene 1 enabled)	0-100, 0 default setting
Scene 5: Pos. height in % (blind operation only and only if scene 5 enabled)	0-100, 0 default setting

Blind 5700/1.0

If "Calibration" in the "X_Blind" tab is "enabled":

X: Calibration	
Parameter	Setting
Reference movement after	No. of movements
	Value "1" to object trigger reference movement
	No. of movements and trigger reference movement
Number of movements until a reference movement is executed (1-20)	1–20, 7 default setting
Reference position	up
	down
	up and down
Automatic calibration	top end position
	top and lower end position
Reference movement delay time via object in seconds (only for "Reference movement object")	disabled , 1–255
Position after reference movement via object (only for "Reference movement object")	New position
	Stay in reference position
	Same position as before reference movement
Height position after reference movement in % (only for "new position")	0–100, 0 default setting
Slat position after reference movement in % (only for "new position")	0–100, 0 default setting

If "Weather alarm" in the "X_Blind" tab is "enabled":

X: Weather alarm	
Parameter	Setting
Responds to wind alarm no.	no response
	1
	2
	3
	1 OR 2
	1 OR 3
	2 OR 3
	1 OR 2 OR 3
	1 AND 2
	1 AND 3
	2 AND 3
1 AND 2 AND 3	
Response to wind alarm(s)	no response
	Up
	Down
	Move to position
Response to rain alarm	no response
	Up
	Down
	Move to position
Response to frost alarm	no response
	Up
	Down
	Move to position
Height position on weather alarm in %	0–100, 0 default setting
Slat position on weather alarm in %	0–100, 0 default setting

X: Weather alarm	
Parameter	Setting
Behaviour on end of all weather alarm functions	no response
	Up
	Down
	Move into position prior to weather alarm
	Assume current automatic position

If "Alarm function" in the "X_Blind" tab is "enabled":

X: Alarm function	
Parameter	Setting
Alarm	For object value "0"
	For object value "1"
Behaviour on alarm start	no response
	Up
	Down
	Move to position
Behaviour on alarm end	no response
	Up
	Down
	Move to position
Alarm status on bus voltage recovery	inactive
	active
	as before bus voltage failure
Height position on alarm start in % (only for "Move to position")	0–100, 0 default setting
Slat position on alarm start in % (only for "Move to position")	0–100, 0 default setting

If "Disable function" in the "X_Blind" tab is "enabled":

X: Disable function	
Parameter	Setting
Lock	For object value "0"
	For object value "1"
Behaviour on lock start	no response
	Up
	Down
	Move to position
Behaviour on lock end	no response
	Up
	Down
	Move into position prior to lock
	Assume current automatic position
Lock status on bus voltage recovery	inactive
	active
	as before bus voltage failure
Height position on lock start in % (only for "Move to position")	0–100, 0 default setting
Slat position on lock start in % (only for "Move to position")	0–100, 100 default setting

If "Movement range limits" in the "X_Blind" tab is "enabled":

Blind 5700/1.0

X: Movement range limits	
Parameter	Setting
Limit movement range	Immediately after bus voltage recovery
	For object value "0"
	For object value "1"
upper limit value in %	0–100, 0 default setting
lower limit value in %	0–100, 0 default setting

If "Failure behaviour" in the "X_Blind" tab is "enabled":

X: Failure behaviour	
Parameter	Setting
Behaviour on bus voltage failure (fixed pause on reverse = 300 ms)	no response
	Stop
	Up Down
Behaviour on bus voltage recovery	Stop
	Up Down
	Move to position
Relay status after download	Stop
	as for bus voltage recovery
Height position on bus voltage recovery in % (only for "Move to position")	0–100, 0 default setting
Slat position on bus voltage recovery in % (only for "Move to position")	0–100, 0 default setting

If "Status messages" in the "X_Blind" tab is "enabled":

X: Status messages	
Parameter	Setting
Height status	disabled
	active status feedback object
	passive status object
Slat status	disabled
	active status feedback object
	passive status object
Automatic status	disabled
	active status feedback object
	passive status object
Disable message type	Drive lock
	Movement range limit
Drive lock status (if disable message type = drive lock)	disabled
	active status feedback object
	passive status object
Movement range limit status (if disable message type = movement range limit)	disabled
	active status feedback object
	passive status object