

Product – and Applications Description

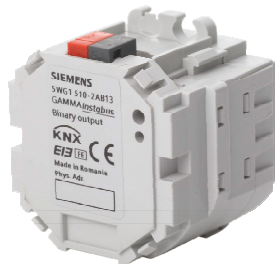

The UP 510/13 Binary output (relay) with mounting frame is a KNX device with two switching outputs. The device is installed in a flush-mount wall box (60 mm Ø, depth 60 mm). The bus is connected via a bus terminal block. The actuator electronics are supplied via the bus voltage.

The UP 510/13 can switch resistive loads (e.g. electrical heaters, incandescent lamps, high voltage halogen lamps), inductive loads (e.g. motor, low voltage halogen lamps with intermediate conventional transformers), or capacitive loads (e.g. low voltage halogen lamps with intermediate electronic transformers).

Each actuator output may be configured independently to provide switching, manual override, forced control, logical gate, and status reporting. Furthermore, if required, time-limited switching instead of permanent switching on can be enabled for each channel via an optional "Night mode" object (e.g. for lighting while cleaning), if need be with a warning before switching off by multiple switching the output on and off (flashing).

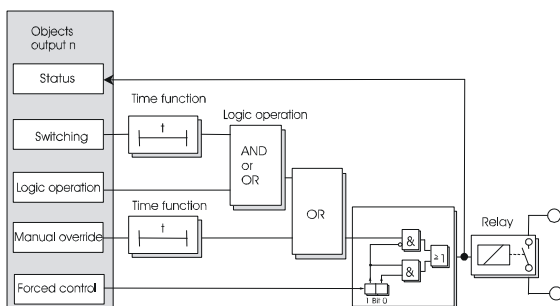

Amongst others, the application program includes optional a switching cycle and operating hours count with threshold monitoring for each output and an integrated 8-bit scene control, in which each output can be incorporated into up to 8 scenes.

Each output of the actuator may be set to one of the following operating modes:

- Normal operation
- Timer operation

Behavior at bus voltage failure / recovery

On bus voltage failure the current switching status value is saved for restoration on bus voltage recovery.

On bus voltage recovery the configured actions are executed and, if applicable, new status values are reported.

Building site function

The building site function provided ex-factory enables switching the building site lighting on and off via bus wall switches and actuators, even if these devices have not yet been commissioned with ETS.

Behavior on unloading the application program

When the application program is unloaded with ETS the building site function available as ex-factory default setting is activated.

The device is configured and commissioned with the ETS (Engineering Tool Software) version ETS3 v3.0f or later.

Application Programs

The UP 510/03 Binary output (relay) needs the application program "07 B0 A2 Switching Actuator 982E01".

Example of operation

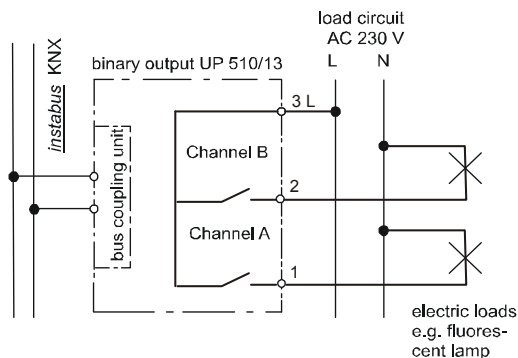

figure 1: Example of operation

Installation instructions

- The device may be used for permanent interior installations in dry locations within flush-mount boxes.



DANGER

- The device must be mounted and commissioned by an authorized electrician.
- A safety disconnection of the device must be possible.
- The device may be mounted to switch and socket combination box mounts provided VDE-certified devices are used exclusively.
- The device must not be opened.
- For planning and construction of electric installations, the relevant guidelines, regulations and standards of the respective country are to be considered.
- **When looping through the L-conductor, take care that the maximum permissible terminal load current of 16A is not exceeded!**

Technical Data

Power supply

- via the bus line
- KNX bus voltage: DC 24V (DC 21...30V) via KNX/EIB bus line
- KNX bus current: < 10 mA

Outputs

- Number: 2 outputs (potential free contacts)
- rated voltage: AC 230V, 47 ... 63Hz
- rated current: 10A resistive load
- switching current at AC 230V: 0,01 ... 10A resistive load
- switching current at DC 24V:
 - 10A resistive load
 - 4A inductive load (L/R = 7ms)
- Switching characteristic:
 - set in parameter list according to application program

Switching capacity at AC 230V

- for incandescent lamp load: max. 1000W
- for fluorescent lamp load (LL):
 - uncompensated LL, $\cos\varphi = 0,5$: max. 500W
 - parallel compensated LL, $\cos\varphi = 1$ (at $C_{ges} \leq 14\mu F$): 2 x 58W or 3 x 36W or 6 x 18W
 - Duo-configuration, $\cos\varphi = 1$: max. 1000W
 - OSRAM ECG for 58W LL: max. 10 pcs.
 - OSRAM ECG for 36W LL: max. 15 pcs.
 - OSRAM ECG for 18W LL: max. 20 pcs.

Control elements

- 1 learning button:
 - for switching between normal operating mode and addressing mode

Display elements

- 1 red LED:
 - for monitoring bus voltage and for displaying normal mode/addressing mode

Connections

- Bus line: screwless bus connection block (red-black) 0,6 ... 0,8 mm Ø single core, strip insulation 5mm
- Load circuit: screwless terminals 0.5 ... 2.5mm² single-core, stranded or multi-core, untreated, strip insulation 9 ... 10mm

Binary output (relay) UP 510/13

5WG1 510-2AB13

Physical Specifications

- housing: plastic
- dimensions (L x W x D):
50 x 50 x 41,5 mm
- weight: approx. 70 g
- fire load: approx. 1100 kJ

Electrical safety

- Degree of pollution (according to IEC 60664-1): 2
- Type of protection (according to EN 60529): IP 20
- Overvoltage category (according to IEC 60664-1): III
- Bus: safety extra low voltage SELV DC 24 V
- Relay with μ -contact
- Device complies with: EN 50428

Electromagnetic compatibility

complies with EN 50428

Environmental specifications

- climatic conditions: EN 50090-2-2
- ambient temperature operating: - 5 ... + 45 °C
- ambient temperature non-operating: - 25 ... + 70 °C
- relative humidity (non-condensing): 5 % bis 93 %

Reliability

- Failure rate: 316 fit at 40°C

MarkingsKNX *EIB***CE mark**

complies with the EMC regulations (residential and functional buildings), and low voltage regulations

Location / Function of the Display and Operating Elements

figure 2: Location / function of the display and operating elements

- A1 LED for indicating normal operating mode (LED off) or addressing mode (LED on); returns to normal operating mode automatically after receiving the physical address
- A2 Learning button for switching between normal operating mode and addressing mode and for receiving the physical address
- A3 Type label (with space for physical address of the actuator)
- A4 clamping slots for anchoring the bus lines
- A5 Snap-on cover for bus line and single bus wires
- A6 Bus connection block for single core conductors with 0,6...0,8 mm \varnothing
- A7 Terminal Channel A
- A8 Distance plate
- A9 Terminal L
- A10 Distance plate
- A11 Terminal N
- A12 Label with terminal descriptions
- A13 Identification number of the device

Mounting and Connecting

General description

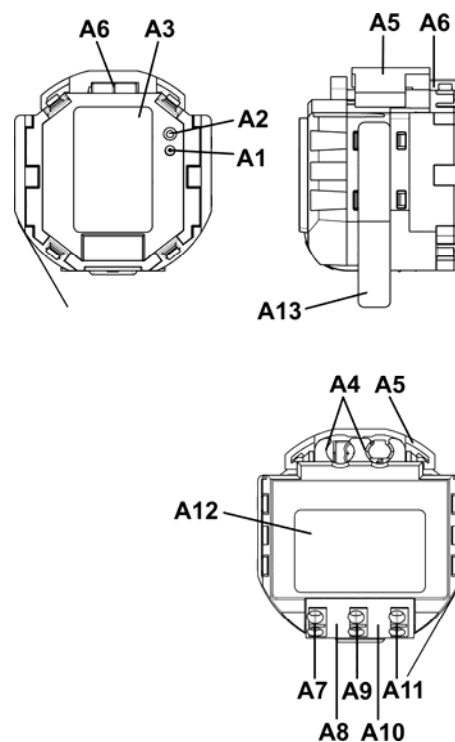
The connection to the bus line is established via bus connection block 193 (screwless plug-in terminals for single core conductors).

Mounting

B1 wall box (60 mm Ø, according to DIN 49073)
B2 Actuator

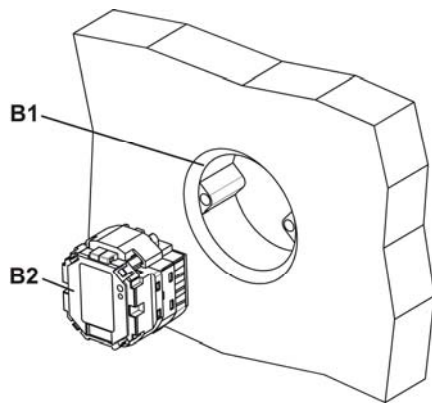

figure 3: Mounting

Slipping off/on bus connection blocks

The bus terminal block (C2) is situated on the side of the actuator (C3).

It consists of two components (C2.1 and C2.2) with four terminal contacts each. Take care not to damage the two test sockets (C2.3) by accidentally connecting them to the bus cable or with the screw driver (e.g. when attempting to unplug the bus terminal block).

Slipping off bus connection blocks

- Put the screw-driver between the cover (C1) and the actuator (C3) from the side and lever out the cover.
- Carefully put the screw driver to the wire insertion slit of the bus terminal block's grey component (C2.2) and
- pull the bus terminal block (C2) from the actuator (C3).

Note

Don't try to remove the bus connection block from the bottom side. There is a risk of shorting-out the device!

Slipping on bus connection blocks

- Slip the bus connection block (C2) onto the guide slot of the actuator (C3) and
- press the bus connection block (C2) down to the stop.
- press the sheathing of the cut-off insulation bus line projecting >3mm into the open clamping slot (C4). If a further bus line shall be connected break out the closed clamping slot with a screw-driver and press it into the clamping slot as described above. Press the single bus wires into the recess below the bus connection block and snap on the cover (C1)

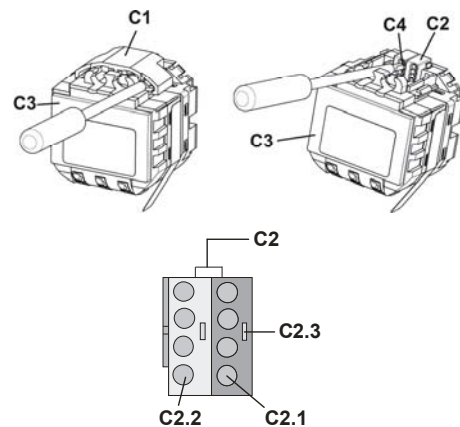

figure 4: Slipping off/on bus connection blocks

Connecting bus cables

- The bus connection block (D2) can be used with single core conductors Ø 0.6...0.8 mm.
- Remove approx. 5 mm of insulation from the conductor (D1) and plug it into the bus connection block (D2) (red = +, grey = -)

Disconnecting bus cables

- Unplug the bus connection block (D1) and remove the bus cable conductor (D2) while simultaneously wiggling it.

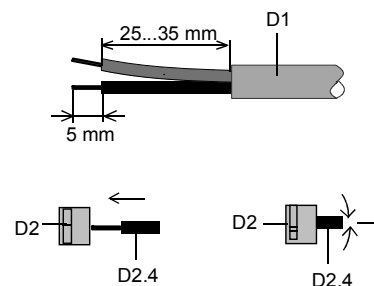

figure 5: Connecting / disconnecting bus cables

Binary output (relay) UP 510/13

5WG1 510-2AB13

Connecting/disconnecting mains and load circuit:Connect wires

- the load circuits are connected via screwless plug-in terminals (E1).
- Remove approx. 9...10 mm of insulation from the wire (E 1.1) and plug it into the terminal (E1).
- The terminals are designed for connection of two wires allowing to loop through the terminal block.

Note:

The maximum permissible terminal load current is 16A.

Remove wires

- Press the terminal interlocking of the terminal (F1) with a screw-driver and remove the wire (F2) from the terminal (F1).

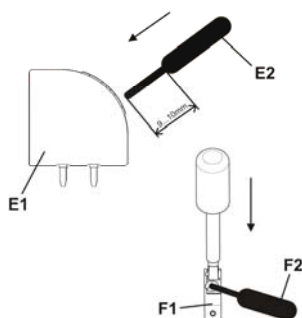
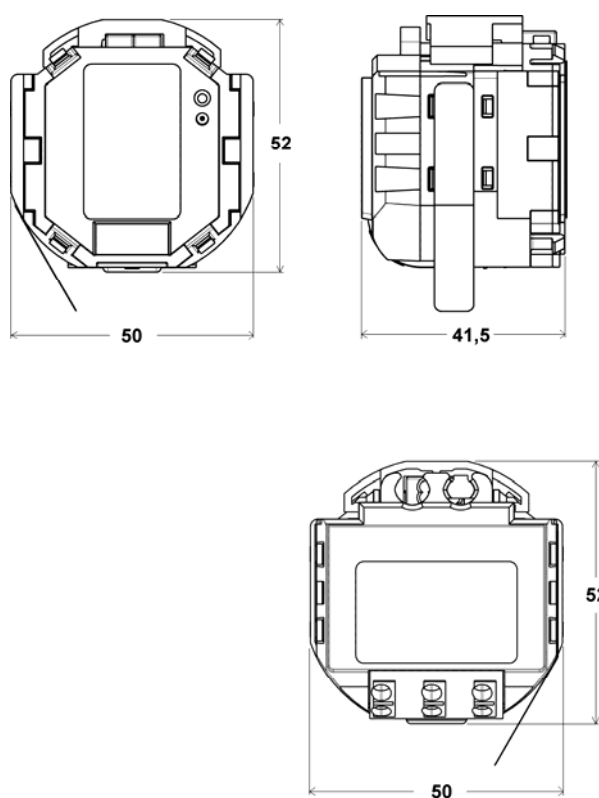

figure 6: Connecting / disconnecting mains and load circuit

Dimension drawing

Dimensions in mm

**General Notes**

- The operating instructions must be handed over to the client.
- A faulty device shall be returned with a Return Good Note for Service provided by the appropriate Siemens sales office.
- If you have further questions concerning the product please contact our technical support.

☎ +49 (911) 895-7222

☎ +49 (911) 895-7223

✉ support.automation@siemens.com

Space for notes:

