

Line/Backbone Coupler N 140/13 **5WG1 140-1AB13**

Product and Applications Description



The line-/ backbone coupler N 140/13 provides a data connection between two separate EIB bus lines and also isolates the bus lines from each other in order to enable the independent local operation of a bus line.

The N 140/13 can be used as line coupler, backbone coupler or repeater as well in existing EIB networks as in new KNX EIB networks. It has a filter table with the help of which bus telegrams are either blocked off from one of the two lines or are passed on to another line thus reducing the bus load. The filter table is created by the ETS (EIB Tool Software) automatically on commissioning the system.

As there are no differences in hardware between the line coupler, the backbone coupler and the repeater they were given the same ordering number. After downloading the physical address the function of the coupler is assigned automatically. Depending on the function of the coupler the following wording is used:

Coupler function	Primary line	Secondary line
Backbone coupler	Backbone line	Main line 1- 15
Line coupler	Main line 1- 15	Line 1- 15
Repeater	Line 1 - 15	Segment (Part) 1-3

The connection to the two bus lines is established:

- a) to the primary line: via bus connection block,
- b) to the secondary line: via bus connection block.

The power supply of the N 140/13 electronics occurs via the connection to the primary line (different to the N 140 !). This makes possible to detect and report a bus voltage failure at the secondary line.

Used as a line coupler, it joins up the lines with the main line to create a function zone; as a backbone coupler, it joins up the function zones with the overriding backbone line. Both types of couplers link primary lines and secondary lines as governed by their filtering tables to only pass on group telegrams if their destination address is recorded in the filtering table.

Used as a repeater the N 140/13 enables the connection of more than 64 bus devices to one bus line. Up to three repeaters can be connected to one bus line (as shown in figure 1) thus enabling the connection of a total of 252 bus devices (additionally to the three repeaters) to one bus line.

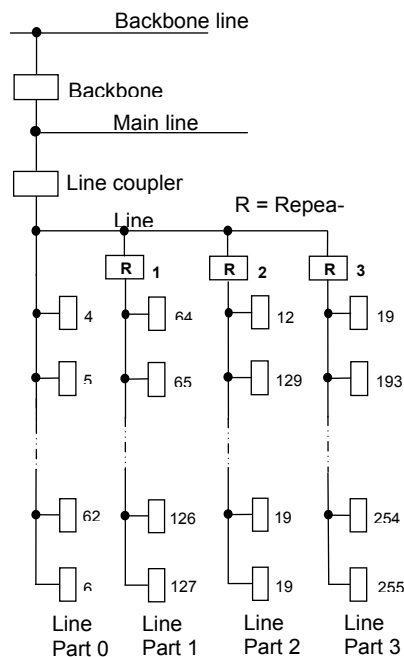

Figure 1. Connection of repeaters to a bus line

Application Programs

The coupler N 140/13 can be programmed with the ETS up from version ETS2V11. Used as a line/backbone coupler the application program “**Coupler 000121**” and used as a repeater the application program “**Repeater 000221**” has to be downloaded.

Please note: when exchanging an already programmed coupler N 140 against a new coupler N 140/13 first the file “**LK_DUMMY.VD1**” has to be loaded into the ETS2 data base. After this a physical address may be assigned to the new N 140/13 and then the old filter table and parameters may be downloaded.

Example of Operation

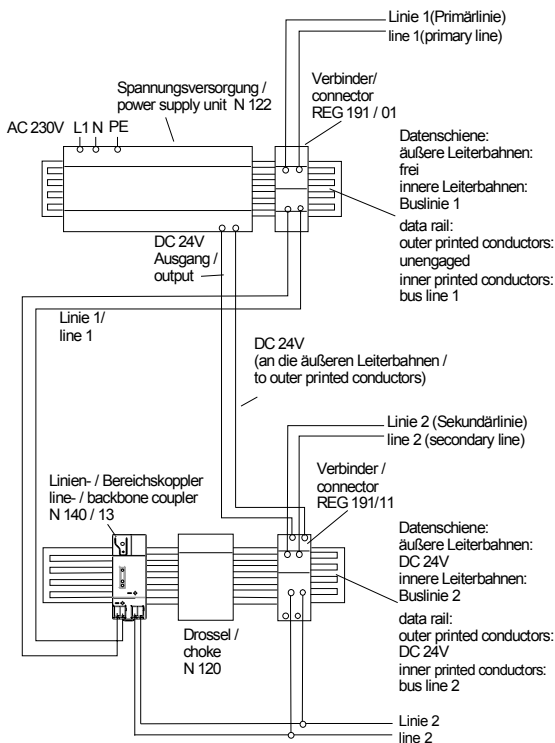

Installation Instructions

- The device may be used for permanent installations in dry locations within distribution boards or small casings with DIN rail EN 60715-TH35-7,5.



WARNING

- The device must be mounted and commissioned by an authorised electrician.
- Unassigned sections of DIN rail with inserted data rail must be covered using 5WG1 192-8AA01.
- The prevailing safety rules must be heeded.
- The device must not be opened.
- For planning and construction of electric installations, the relevant guidelines, regulations and standards of the respective country are to be considered.

Technical Specifications

Rated voltage

- primary line (used for power supply of the device) : DC 24V (DC 21...30V)
- secondary line: DC 24V (DC 21...30V)

Current input

- from primary line: 6 mA
- from secondary line: 8 mA

Operator elements

1 learning button: for switching between normal operating mode and addressing mode

Display elements

- 1 yellow LED: for data reception on the secondary line
- 1 green LED: for 'ready' state
- 1 yellow LED: for data reception on the primary line
- 1 red LED: for controlling bus voltage and displaying the actual mode, selected by the learning button (LED off: normal mode; LED on: addressing mode)

Connections

- primary line / secondary line: screwless bus connection block, 0,6...0,8mm Ø single core insulation strip length 5mm

Physical specifications

- housing: plastic
- dimensions: N-system DIN-rail mounted device, width: 2 SU (1SU = 18 mm)
- weight: approx. 90 g
- fire load: approx. 1750 kJ ± 10 %
- installation: rapid mounting on DIN rail (according to EN 60715-TH35-7,5)

Electrical safety

- degree of pollution (according to IEC 60664-1): 2
- protection (according to EN 60529): IP 20
- protection class (according to IEC 61140): III
- overvoltage class (according to IEC 60664-1): III
- bus: safety extra low voltage SELV DC 24 V
- device complies with EN 50090-2-2 and IEC 60664-1

Electromagnetic compatibility

complies with
EN 61000-6-2, EN 61000-6-3 and EN 50090-2-2

Line/Backbone Coupler N 140/13**5WG1 140-1AB13****Environmental specifications**

- climatic conditions: EN 50090-2-2
- ambient temperature operating: - 5 ... + 45 °C
- storage temperature: - 25 ... + 70 °C
- relative humidity (non-condensing): 5 % to 93 %

CE mark

complies with the EMC regulations (residential and functional buildings), and low voltage regulations.

Markings

KNX / EIB

Location and Function of the Display and Operator Elements

Figure 2: Location of the display and operator elements

- A1 Green LED for 'ready'
- A2 Yellow LED for data reception on the secondary bus line
- A3 Yellow LED for data reception on the primary bus line
- A4 Red LED for indicating normal operating mode (LED off) or addressing mode (LED on); upon receiving the physical address the device automatically returns from addressing mode to normal operating mode
- A5 Learning button for switching between normal operating mode and addressing mode for assigning the physical address
- A6 Bus connection block for secondary line (e.g. line)
- A7 Bus connection block for primary line (e.g. main line)

Mounting and WiringGeneral description

The N-system DIN-rail device (1 SU) can be installed to N-system distribution boards, surface or flush mounted, or to any DIN-rail EN 60715-TH35-7,5 with glued-in data rail.

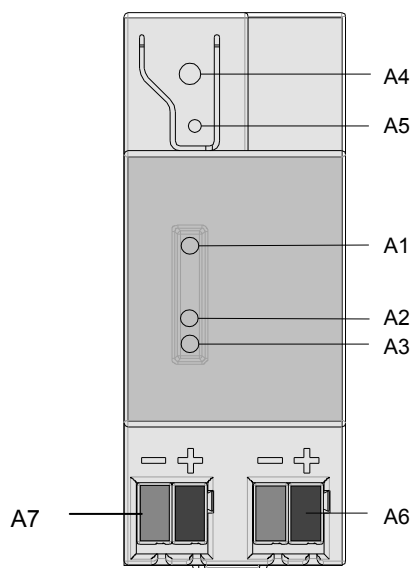
The connection to the secondary bus line is established by clicking the device onto the DIN-rail (with a glued-in data rail). Take care that the type plates of all devices on the DIN-rail can be read in the same direction, guaranteeing the bus voltage being applied to the devices with correct polarity.

Mounting DIN-rail devices (figure 3)

- Slide the device (B1) onto the DIN-rail (B2) and
- swivel back the device until the slide clicks into place audibly.

Dismounting DIN-rail devices (figure 3)

- Remove all connected bus wires,
- press down the slide (C3) with a screw-driver until it clicks into place due to a slight pressure and
- swivel the device (C1) from the DIN-rail (C2).

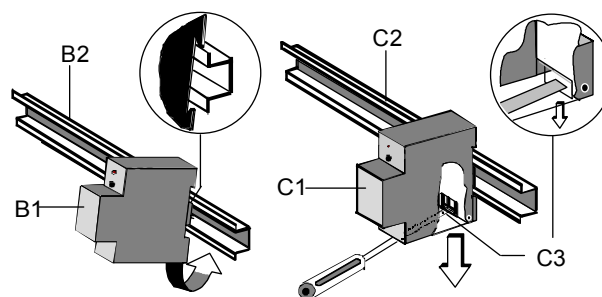

Figure 3: Mounting / dismounting a DIN-rail device

Slipping off bus connection blocks (figure 4)

- The bus connection block (D2) consists of two components (D2.1 and D2.2) with four terminal contacts each. Take care not to damage the two test sockets (D2.3) by accidentally connecting them to the bus cable or with the screw driver (e.g. when attempting to unplug the bus connection block).
- Carefully put the screw driver to the wire inserting slit of the bus connection block's grey component (D2.2) and pull the bus connection block (D2) from the device (D1).

**CAUTION**

Don't try to remove the bus connection block from the bottom side with a screw driver. There is a risk of short-cutting the bus voltage!

Slipping on bus connection blocks (figure 4)

- Slip the bus connection block onto the guide slot and
- press the bus connection block (D2) down to the stop.
- Stick on the bus connection block cover.

Connecting bus cables (figure 4)

- The bus connection block (D2) can be used with single core conductors \varnothing 0,6 ... 0,8 mm.
- Remove approx. 5 mm of insulation from the conductor (D2.4) and plug it into the bus connection block (D2) (red = +, grey = -).

Disconnecting bus cables (figure 4)

- Unplug the bus connection block (D2) and remove the bus cable conductor (D2.4) while simultaneously wiggling it.

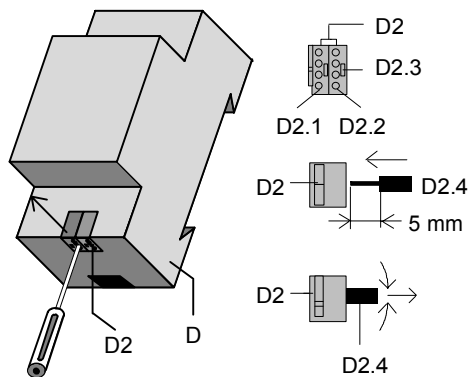
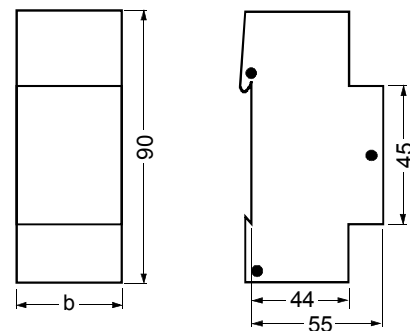

Figure 4: Connecting / disconnecting bus cables

Dimension Diagram

Dimension



$b = 2 \text{ SU}$

1 Spacing unit (SU) = 18 mm

Allgemeine Hinweise

- Any faulty devices should be returned to the local Siemens office.
- If you have further questions about the product, please contact our Technical Support:



+49 (0) 180 50 50-222

+49 (0) 180 50 50-223

www.siemens.de/automation/support-request