

Venetian blind actuator N 523/04
4 x 230 V AC / 6 A

5WG1 523-1AB04

Product and functional description



The Venetian blind actuator N 523/04 is a DIN rail mounted device in N-system dimensions with a width of 4 module units. Only one AC 230V drive (motor) with electro-mechanical limit switches or with integrated electronics for disconnection at the limit positions can be connected to a channel of the 4-fold Venetian blind actuator N 523/04. The parallel operation of several drives on one channel requires the intermediate switching of a special relay. Apart from the possibility to move the sun/sight guard directly into one of its two final positions (via EIS 1 objects) it is also possible for both the sun blind and the slats to be moved independently into intermediate positions, defined in percentages, by positioning commands (EIS 6 objects). This actuator may therefore be used in projects with tracking of the sun's position.

The power supply of the Venetian blind actuator electronics is carried out via an integrated power supply unit, which is fed via the mains connection L1 for channels A and B. The mains connection of channels C and D is carried out via the connection L2. This enables two channels to be connected to different external conductors. If this is not required, one of the terminals L1 must be linked to one of the terminals L2 via a wiring jumper.

For direct operation (also in the event of communications failure or if EIB communication has not yet been put into operation), four pairs of push buttons are available on the top of the device. For direct operation, both AC 230 V and bus voltage must be applied at the actuator. Moreover, the actuator must be switched to direct operation via the appropriate push button with a LED. In direct operation mode, an output remains switched on while the associated push button is pressed. As the direct operation is completely isolated from the bus communication, any active alarm or blockade mode (for blocking the raising or lowering of the sun/anti-glare protection) is not taken into account.

Application program

The sunblind actuator N 523/04 only works together with the application program 25 A4 Venetian blind actuator 981201. The Engineering Tool Software (ETS) up from ETS2 V1.3 is required for the parameterisation and for loading the application program.

This is structured so that there is sufficient basic functionality available in the supplied state for simple applications in combination with 11 basic communication objects: the always available object "Status Direct mode", an alarm object that influences all channels, an object "Blockade" that also influences all channels and the two 1-bit command objects per channel enabling a blind to be moved into the upper or lower final position, to stop the drive and to open or close the slats stepwise. When commissioning the sunblind actuator the following objects can be added per channel, if needed, via the parameter tab "Functions, Objects":

- one "Alarm" object,
- one "Blockade" object,
- the objects for Automatic mode and
- one "Sun" object per device or per channel or
- two 8-bit command objects for standard operation mode (Venetian blind and slat position in %),
- two 8-bit status objects (blind and slat position in %),
- up to two 1-bit status objects (upper / lower final position reached).

It can further be selected whether the parameterisation is adopted for all the channels or by pairs or whether each channel should be configured individually.

Note: After an "unload" of the application program with the ETS the device will be without any function. Even the direct operation is impossible.

Connection example

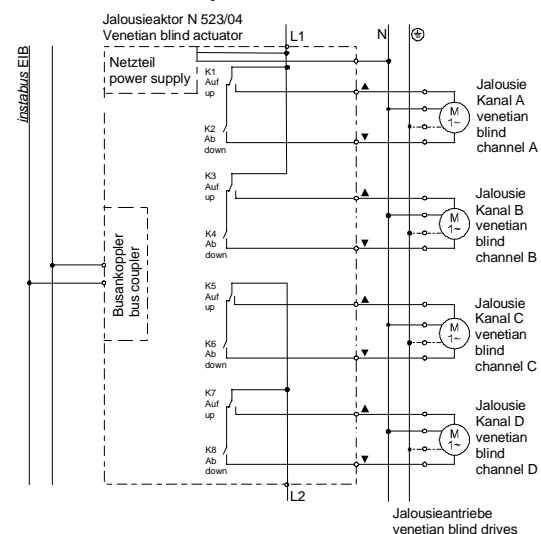

Venetian blind actuator N 523/04
4 x 230 V AC / 6 A

5WG1 523-1AB04

Notes for installation

The device may be used for permanent interior installations in dry locations within distribution boards or small casings with DIN rail EN 60715-TH35-7.5.



DANGER

- The device must be mounted and commissioned by an authorised electrician.
- When connecting the device, it should be ensured that the device can be isolated.
- The device must not be opened.
- For planning and construction of electric installations, the relevant guidelines, regulations and standards of the respective country are to be considered.
- In the case of motors with electronic limit switches, the switching points must be adapted on site.

Technical data

Power supply

- Bus voltage: carried out via the bus line
- N 523 electronics: integrated power supply unit 230V AC, +10% / -15%, 50Hz
- Supply voltage for bus: 21V DC to 30V DC

Operating elements

- 1 push button:
for toggling between normal mode / addressing mode
- 1 push button:
for toggling between bus / direct operation
- 4 x 2 push buttons:
for direct operation of the Venetian blind drives, independent of the EIB

Display elements

- 1 red LED: for displaying normal mode / addressing mode (off / on)
- 1 yellow LED: for displaying bus / direct operation (off / on)

Inputs/outputs

- Mains connection:
 - 2 x 2-pole (N, L1) (L1 is also the power supply for outputs A and B)
 - 2-pole L2 (power supply for channels C and D)
- 4 load outputs for 4 Venetian blinds:
 - each 2-pole (up, down)
 - rated voltage: AC 230 V, 50Hz
 - rated current per relay contact: 6 A (resistive load)
 - Switching cycles: >20,000 at $\cos \varphi = 1$

Connections

- Load circuit, mechanical:
 - Insulation strip length 9... 10 mm
 - The following conductor cross-sections are permitted:
 - 0.5... 2.5 mm² single-core or finely stranded
 - 0.5... 2.5 mm² finely stranded with plug connector, sealed crimp connection
 - 0.5... 1.5 mm² finely stranded with connector sleeve
 - 1.0 and 1.5 mm² finely stranded, untreated
- Load circuit, electrical:
 - Finely stranded conductor, untreated, from 1mm²: current-carrying capacity of max. 6 A
 - Finely stranded conductor, with plug connector, sealed crimp connection, from 1.5mm²: current-carrying capacity max. 10 A
 - All other conductors from 1.5mm²: current-carrying capacity of max. 10A.
- Bus line: Pressure contacts on data rail and bus terminal



DANGER

When looping through the L and N conductors, it should be noted that the maximum terminal current of 10 A, which is limited by the permitted printed conductor load, may not be exceeded.

Mechanical data

- Housing: plastic
- Dimensions: DIN rail mounted device in N-system dimensions, width: 4 modules (1 module = 18 mm)
- Weight: approx. 260 g
- Fire load: approx. 3600 KJ \pm 10%
- Installation: snap-on fixing onto DIN rail EN 60715-TH35-7.5

Electrical safety

- Degree of pollution (in accordance with IEC 60664-1): 2
- Protection type (in accordance with EN 60529): IP 20
- Bus: safety extra-low voltage SELV DC 24 V
- Device complies with EN 50090-2-2 and EN 60669-2-1

EMC requirements

complies with EN 50090-2-2

Environmental conditions

- Ambient operating temperature: - 5 ... + 45 °C
- Storage temperature: - 25 ... + 70 °C

Venetian blind actuator N 523/04
4 x 230 V AC / 6 A

5WG1 523-1AB04

Markings

KNX / EIB

CE mark

In accordance with the EMC guideline (residential and functional buildings) and the low voltage guideline

Location and function of the display and operating elements

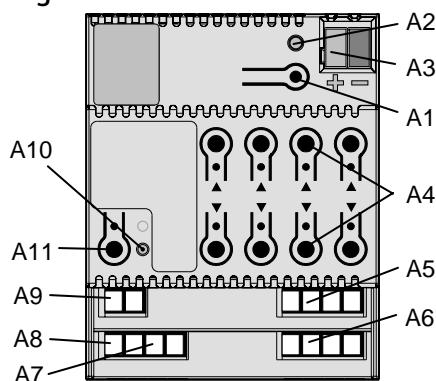

Figure 1: Location of the display and operating elements

- A1 Commissioning button
- A2 Commissioning LED
- A3 Bus terminal
- A4 Buttons for direct operation UP/DOWN of a sunblind
- A5 Terminals for sunblind UP/DOWN (Channel C + D)
- A6 Terminals for sunblind UP/DOWN (Channel A + B)
- A7 Terminals N
- A8 Terminals L1
- A9 Terminals L2
- A10 LED direct operation
- A11 Button for toggling between bus / direct operation

Mounting and wiring

General description

The DIN rail mounted device with N-system dimensions (4 module units) can be inserted in N-system distribution boards, either surface- or flush-mounted, and wherever DIN rails EN 60715-TH35-7.5 are available. The contact with the bus line is carried out via the bus terminal or via the contact system to the data rail.

Assembling the DIN rail mounted device (Figure 2)

- Place the device (B1) on the DIN rail (B2) and
- rotate the device downwards until the slide switch audibly clicks into position.

Dismantling the DIN rail mounted device (Figure 2)

- Remove all the connected cables,
- press the slide switch (B3) down with a screwdriver and
- remove the device (B1) from the DIN rail (B2) with a swivel action.

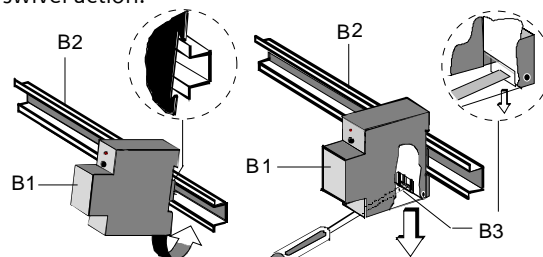

Figure 2: Assembling and dismantling the DIN rail mounted device

Removing the bus terminal (Figure 3)

- The bus terminal is located on the top of the Venetian blind actuator N 523/04 (C1)
- The bus terminal (C2) consists of two sections (C2.1, C2.2), each with four terminal contacts. Care should be taken not to damage the two test sockets (C2.3) either by accidentally connecting them to the bus conductor or with the screwdriver when attempting to remove the bus terminal.
- Carefully insert the screwdriver into the black part of the bus terminal (C2.1) and pull the bus terminal forwards out of the Venetian blind actuator N 523/04 (C1).

Note

When removing the bus terminal, there is a danger of short circuits.

Plugging in the bus terminal (Figure 3)

- Place the bus terminal (C2) in the guide slot and
- press downwards until it reaches the stop.

Connecting the bus cable (Figure 3)

- The bus terminal (C2) is suitable for single-core conductors with 0.6 ... 0.8 mm Ø.
- Strip approx. 5 mm of insulation from the conductor (C2.4) and then plug in the terminal (C2) (red = +, black = -).

Disconnecting the bus cable (Figure 3)

- Remove the bus terminal (C2) and the conductor (C2.4) from the bus cable by rotating them simultaneously backwards and forwards.

Venetian blind actuator N 523/04
4 x 230 V AC / 6 A

5WG1 523-1AB04

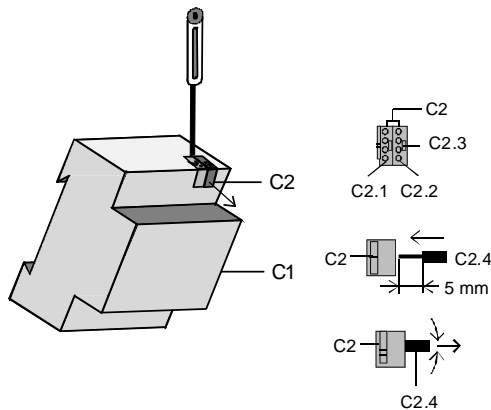

Figure 3: Connecting and removing the cable

Connecting the mains voltage and Venetian blind drives

- The connections are carried out with plug-in terminals.
- Strip approx. 9-10 mm of insulation from the conductor and slide into the respective terminal.
- Outputs A and B are supplied via terminal L1 while outputs C and D are supplied via terminal L2. This enables two outputs to be connected to different external conductors. If all the actuator outputs should be connected to the same external conductor, a terminal L1 must be linked to a terminal L2 via a wiring jumper.

Cross-sections:

- The following conductor cross-sections are permitted:
 - 2 x 0.5... 2.5mm² single-core or 2 x 0.5... 1.5mm² finely stranded with connector sleeve
- Each of the mains connections L1 and L2 must be fused with a miniature circuit breaker of characteristic B or C with a max. nominal current of 10 A.

Mounting the insulating cap

If the device should be mounted on a DIN rail without an data rail, the contact system must be covered with the supplied insulating cap.

Removing the locating clamp: (Figure 4)

- The locating clamp (D3) encloses the contact system (D2) on the rear of the Venetian blind actuator (D1).
- Insert the screwdriver between the DIN rail mounted device (D1) and the locating clamp (D3) and remove the clamp.

Clipping on the insulating cap: (Figure 4)

Place the insulating cap (D4) on the contact system and press so that it snaps in place.

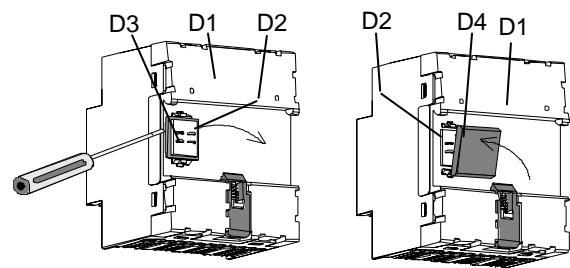
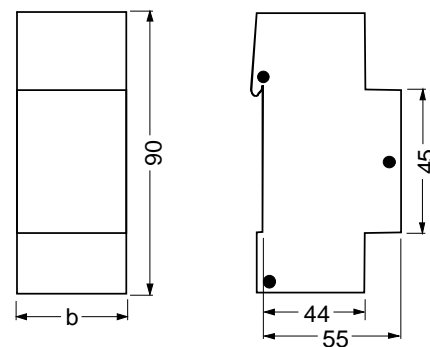

Figure 4: Covering the contact system

Dimension drawing

Dimensions in mm



b = 4 module units

1 module unit = 18 mm

General notes

- Any faulty devices should be returned to the local Siemens office.
- Should you have any additional queries, please contact our Technical Support department:



+49 (0) 180 50 50-222



+49 (0) 180 50 50-223



www.siemens.com/automation/support-request