

12 S1 Mot.detect. central 211E01

Use of the application program

Product family: Physical sensors
 Product type: Motion detector
 Manufacturer: Siemens

Mounting height 1.10 m and 2.20m:

Name: Motion detector UP 258H
 DELTA i-system
 Order no.: 5WG1 258-2HB__

Name: Motion detector UP 255
 DELTA profil
 Order no.: 5WG1 255-2AB__

Name: Motion detector UP 257
 DELTA style
 Order no.: 5WG1 257-2AB__

Name: Motion detector UP 256
 DELTA ambiente
 Order no.: 5WG1 256-2AB__

Functional description

With the application program "12 S1 Mot.detect. central 211E01", it is possible to operate the motion detectors UP 255 and UP 256 as a central unit when linked with an unlimited number of extension units. The application can run on bus coupling units with BCU 1.2 and BCU 2.0.

Operation as a central unit

On the one hand, the central unit records movement in its own detection area and on the other hand evaluates the movement detected by the extension units. After the logical connection of both sources of information, switching telegrams are transferred via the bus.

An "On" telegram is sent when movement is sensed in the detection range of the central unit or of an extension unit. If no movement is recorded in the detection areas of all the motion detectors for at least 10 seconds, an "Off" telegram is sent (corresponds quasi to a minimum overshoot time of 10 seconds).

The interval until the "Off" telegram is sent can be extended using the ETS parameter "Overshoot time". If a set overshoot time is running, it is retriggered when a new movement is detected which means that the set period restarts once the movement has ended. The "On" telegram is also sent again in this case.

If movements last for a longer period or occur within the minimum overshoot time, the "On" telegrams can be repeated with a configurable cyclic time (minimum value 10 seconds) using the parameter "Cyclical sending at motion detection".

If movement is recorded in the detection range of the central unit, a notification telegram is also sent to the extension units via object no. 2, if no movement has been detected by the central unit or an extension unit up to this point.

Once the "Off" telegram has been triggered at the end of the overshoot time, the detector can be disabled for an adjustable dead time (default value 3 seconds). There is no more cyclical sending once the minimum overshoot time has elapsed (10 seconds). A dead time which is set in the central unit also influences all the extension units as a report of movement by an extension unit only leads to an "On" telegram being triggered once the dead time in the central unit has elapsed.

A dead time > 0 should only be set in the central unit if it is required for all detectors in parallel operation. If the setting of dead times > 0 is only required in individual detectors, these should always be set in the extension units as they then only apply to the individually specified detectors. The reports of movement that have been sent by other extension units to the central unit can then lead immediately to the triggering of an "Off" telegram.

An adjustable brightness level ensures that the central unit only senses the start of any movement in its own detection area below this ambient brightness level and triggers "On" telegrams.

The evaluation of movement detected by the extension units is carried out depending on the brightness level set in the central unit. It is therefore possible to define different lux values as brightness levels in the central and extension units and thus adapt to different ambient brightness levels in the range of the detector.

It is possible to disable the operation of the detector via a special object. Once the blocking function has been deactivated, the detector is able to start detection immediately, without a dead time being started.

After bus voltage recovery, the detector is further immunised for a period of 80 seconds as the magnification level of the motion detector must be set to a defined output state during this period.

12 S1 Mot.detect. central 211E01

Wiring diagram

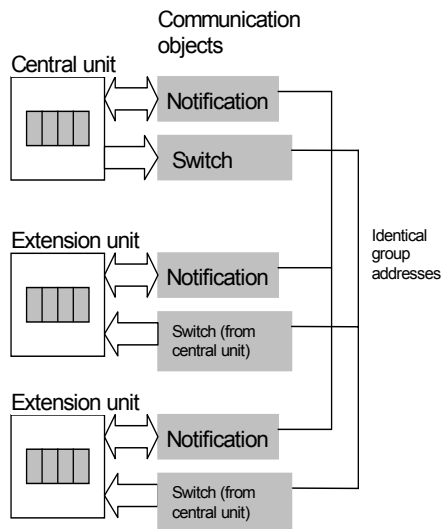

Multiple operation with a central and extension units

In multiple operation, the central unit and all the extension units communicate both via the notification object and the switching object.

During the configuration, the objects "Switch" and "Notification" for the central unit and all the extension units must be linked via identical group addresses.

The group addresses of the blocking objects of the central unit and extension units can differ.

Max. number of group addresses: 6

Max. number of associations: 6

Communication objects

Phys. Addr.		Program		
no.	Function	Object name	Type	
01.01.013		12 S1 Mot.detect. central 211E01		
0	On / Off	Switch	1 Bit	
1	activated / deactivated	Blocking	1 Bit	
2	On	Notification	1 Bit	

Obj	Function	Object name	Type	Flags
0	On / Off	Switch	1 Bit	CW
The switching telegrams are sent via this object.				
1	activated / deactivated	Blocking	1 Bit	CW
The operation of the detector can be blocked via this object. Depending on the parameter settings, the detection of movement and the sending of telegrams via the switching object can be disabled or enabled via an external bus telegram.				
If the setting "On = Operation, Off = Blocking" is selected, the blocking function is activated once the bus voltage has been applied as the object value after a reset of the bus coupling unit is identical to "Off".				
2	On	Notification	1 Bit	CWT
The signals of the extension units are received and the signal from the central unit to the extension units is transmitted via this object. Only the telegram value "On" is sent.				

Parameters

General	
Motion Detection	up to brightness level 15 lux
Cyclical sending at motion detection	disabled
Base for overshoot time	Time base 520 ms
Factor for overshoot time (0-127)	0
Base for dead time after end of motion detection	Time base 130 ms
Factor for dead time after end of motion detection (0-255)	23
Operation mode of blocking object	Off = Operation, On = Blocking

Parameters	Settings
Motion Detection	disabled up to brightness level 1 lux up to brightness level 2 lux up to brightness level 5 lux up to brightness level 10 lux up to brightness level 15 lux up to brightness level 20 lux up to brightness level 50 lux up to brightness level 100 lux up to brightness level 200 lux up to brightness level 500 lux up to brightness level 1000 lux Brightness independent

12 S1 Mot.detect. central 211E01

Parameters	Settings
<p>With this parameter, the reporting of movement can be controlled dependent on the level of ambient brightness. "disabled": No reporting of movement takes place by the central unit in the form of switching telegrams. Notification telegrams from the extension units are not evaluated. "up to brightness level ... lux": Movement in the detection range of the central unit is only reported if the ambient brightness level lies below the value set here. The evaluation of movement signals from the extension units is carried out <u>regardless</u> of the brightness level set in the central unit. "Brightness independent": Movement is reported regardless of the level of ambient brightness.</p>	
Cyclical sending at motion detection	disabled enabled
<p>With this parameter, the cyclical sending of the switching object no. 0 is controlled during the phase of motion detection. "disabled": No cyclical sending takes place. "enabled": The value of the switching object is sent cyclically on the bus with the set cyclic time. Note: Once the set overshoot time has elapsed, there is no more cyclical sending.</p>	
Base for overshoot time	Time base 130 ms Time base 260 ms Time base 520 ms Time base 1.0 sec Time base 2.1 sec Time base 4.2 sec Time base 8.4 sec Time base 17 sec Time base 34 sec Time base 1.1 min Time base 2.2 min Time base 4.5 min Time base 9 min Time base 18 min Time base 36 min Time base 1.2 hrs
Factor for overshoot time (0-255)	0
<p>With these parameters, the time can be set when an "Off" telegram is sent on the bus via the switching object once the minimum overshoot time has elapsed. The resulting overshoot time is produced from the minimum overshoot time of 10 seconds plus the period set here (calculated from the time base multiplied by the factor entered here).</p>	
Base for dead time after end of motion detection	Time base 0.5 ms Time base 8 ms Time base 130 ms Time base 2.1 sec Time base 33 sec

Parameters	Settings
Factor for dead time after end of motion detection (0-255)	23
<p>These parameters define the dead time after the "Off" telegram has been sent. Motion detection only takes place again once this period has elapsed. This can be necessary to prevent error signals e.g. due to powerful light sources which would cause a significant thermal change for movement detection when they cool down. The dead time is produced from the time base multiplied by the factor entered here.</p>	
operation mode of blocking object	Off = Operation, On = Blocking On = Operation, Off = Blocking
<p>The function of the telegram values of the blocking object no. 1 is defined with this parameter: "Off = Operation, On = Blocking": The sending value "Off" enables the operation of the detector while the sending value "On" activates the blocking function. "On = Operation, Off = Blocking": The sending value "On" enables the operation of the detector while the sending value "Off" activates the blocking function. Note: When this setting is selected, the blocking function is activated when the bus voltage is applied, as the object value after a reset of the bus coupling unit is identical to "Off".</p>	

Note:

For technical reasons, the selected periods can be up to 25 % longer than set.