

FEATURES

- 2 different configurable blocks:
 - Shutter channels (up to 4).
 - Individual outputs (up to 8).
 - 2-pipe fan coil control (up to 2 units).
- Manual output operation with push button and LED status indicator.
- Suitable for capacitive loads, maximum **140 µF**.
- Logical functions included.
- Output timing facilities.
- Total data saving on power failure
- Size 67 x 90 x 79 mm (4.5 DIN units).
- DIN rail mounting (EN 50022), through pressure.
- No external power supply required other than the bus.
- KNX BCU integrated.
- Possibility to connect different phases in adjoining outputs.
- Compliant with the CE directives (CE-mark on the right side).

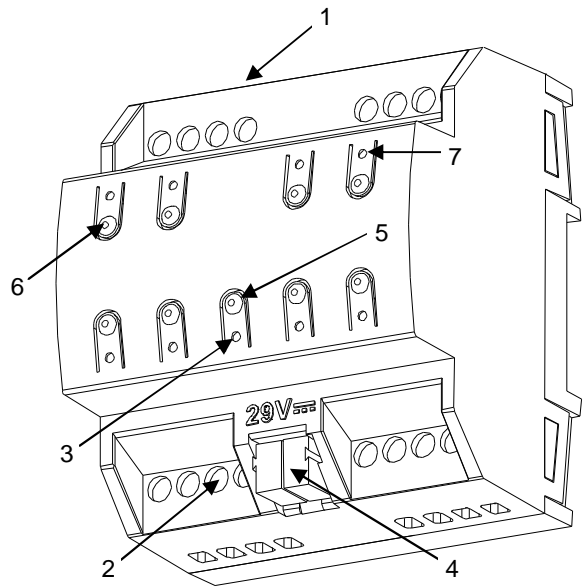

Figure 1. MAXinBOX 8 Plus

1. Upper outputs	2. Lower output screws	3. Programming/Test LED	4. KNX connector
5. Programming/Test button	6. Output control button	7. Output status LED indicator	

Programming/test button: short press to set programming mode. If this button is held while plugging the device into the KNX bus, it enters the safe mode. If this button is held for more than 3 seconds, the device enters the test mode.

Programming/Test LED: programming mode indicator (red). When the device enters into safe mode, it blinks (red) every half second. The manual mode is indicated by the green color. During the start-up (reset or after KNX bus failure) and if the device is not in safe mode, it starts a blue blinking sequence.

GENERAL SYSTEM SPECIFICATIONS

CONCEPT		DESCRIPTION		
Type of device		Electric operation control device		
KNX supply	Voltage (typical)	29V DC SELV		
	Voltage range	21...31V DC		
	Maximum consumption	Voltage	mA	mW
		29VDC (typical)	5.8	168.2
24VDC ⁽¹⁾	10	240		
Bus connection		Typical bus connector TP1 for rigid cable 0.80mm Ø		
External power supply		No		
Operation temperature		from 0°C to +55°C		
Storage temperature		from -20°C to +70°C		
Operation humidity		5 to 95% RH (no condensation)		
Storage humidity		5 to 95% RH (no condensation)		
Complementary characteristics		Class B		
Protection class		II		
Operation type		Continuous operation		
Device action type		Type 1		
Electrical stress period		Long		
Degree of protection		IP20, clean environment		
Installation		Independent device to be mounted inside electrical panels with DIN rail (EN 50022)		
Response on KNX bus failure		Data saving and relays open if channel configured as shutter.		
Response on KNX bus restart		Data recovering and output status change according to programming when recovering.		
Operation indication		Programming LED indicates programming mode (red) and test mode (green). Output status LED indicators reflect current output state.		
Weight		290g		
PCB CTI index		175 V		
Housing material		PC FR V0 halogen free		

⁽¹⁾ Maximum consumption in the worst case scenario (KNX Fan-In model)
© Zennio Avance y Tecnología S.L. Edition 2

OUTPUTS SPECIFICATIONS AND CONNECTIONS		
Contact type		Potential free outputs through bistable relays with tungsten pre-contact.
Disconnection type		Micro-disconnection
Rated current by output		~16(6)A * 250V AC (4000 VA)  16(6)A * 30V DC (480W)
Maximum inrush current		800A/200µs (fluorescent lamps) 165A/20ms (resistive lamps)
Outputs per common		1 individual output
Different phases connection		Possibility to connect different phases in adjoining outputs
Maximum current		80A
Maximum power	Resistive load	4000W
	Inductive load	1500W
Connection type		Screw terminal block
Recommended cable section		0,5mm ² to 4mm ² (26-10AWG)
Cable type		Stranded or solid wire.
Maximum response time		50ms
Expected life	Mechanical (min)	3 million operations (60cpm)
	Electrical (min.)	100.000 cycles at max. current (6cpm and resistive load)

WIRING AND ASSEMBLY DIAGRAMS

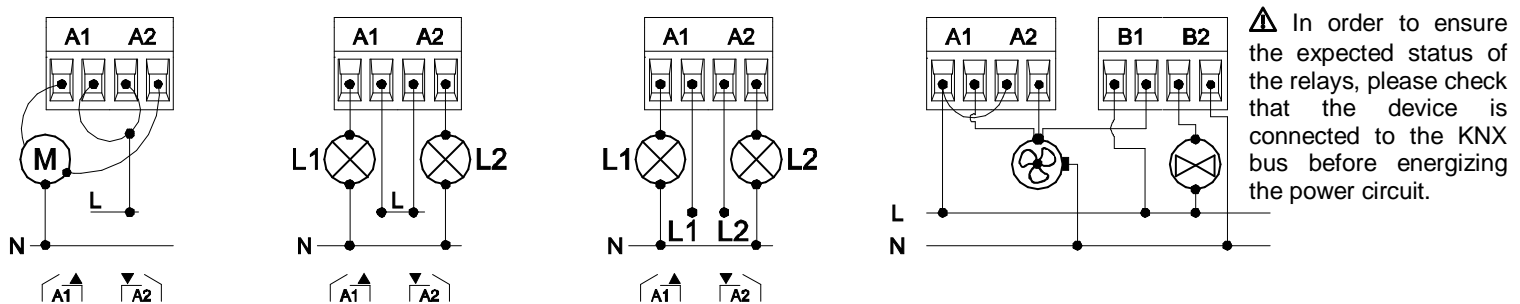
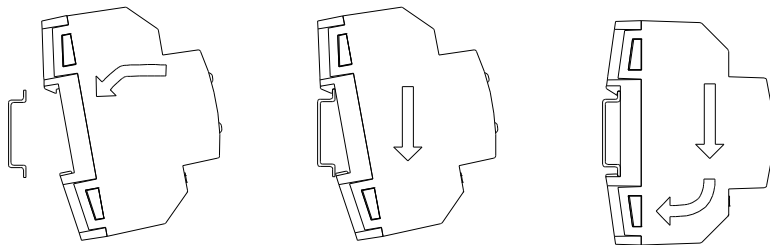

Figure 2. Wiring examples (from left to right): channel A as shutter channel, individual outputs in channel A with the same and different phases and channel A and B as fan coil controller (2 pipe and three-speed fan).

Attaching MAXinBOX 8 Plus to DIN rail:



Removing MAXinBOX 8 Plus from DIN rail:

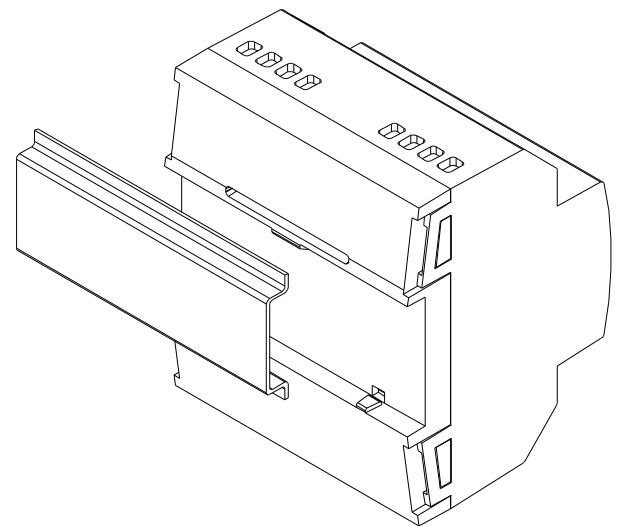
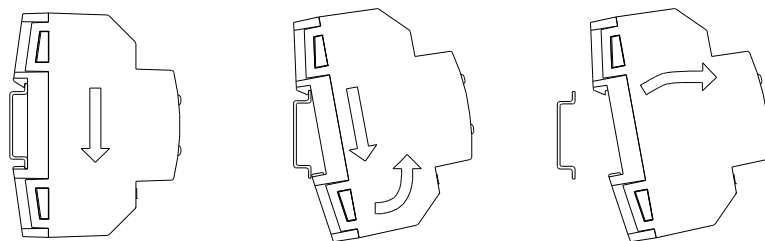

Figure 3. Installation of MAXinBOX 8 Plus on DIN rail

SAFETY INSTRUCTIONS

- Installation should only be performed by qualified professionals according to the laws and regulations applicable in each country.
- Do not connect the mains voltage nor any other external voltage to any point of the KNX bus; it would represent a risk for the entire KNX system. The facility must have enough insulation between the mains (or auxiliary) voltage and the KNX bus or the wires of other accessories, in case of being installed.
- Once the device is installed (in the panel or box), it must not be accessible from outside.
- Keep the device away from water and do not cover it with clothes, paper or any other material while in use.
- The WEEE logo means that this device contains electronic parts and it must be properly disposed of by following the instructions at <http://zennio.com/weee-regulation>.

