

# Installation Manual

## ACUAZONE IBPRO32

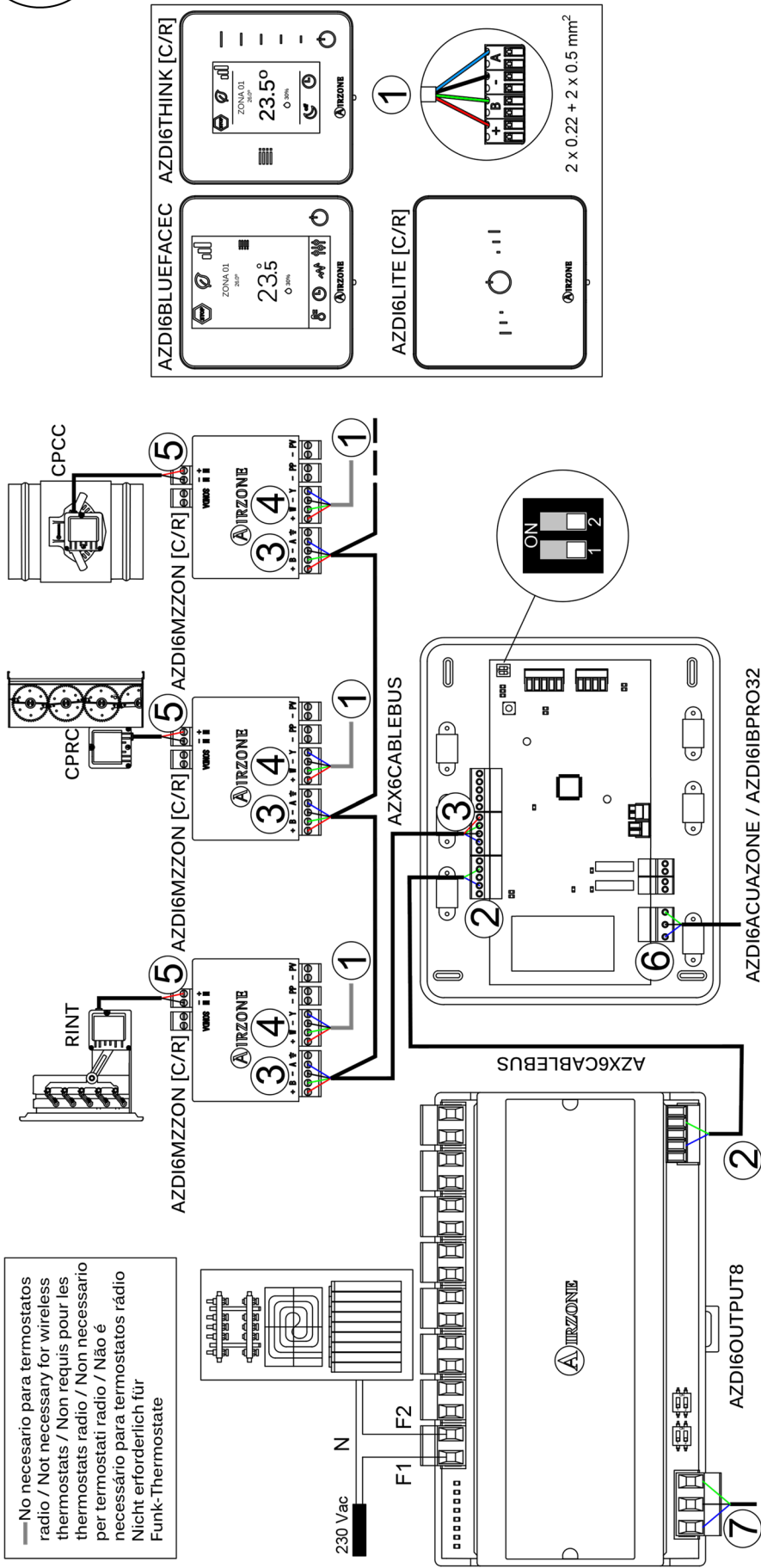

# ZONED CONFIGURATION

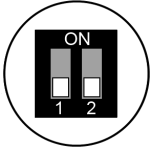

— No necesario para termostatos radio / Not necessary for wireless thermostats / Non requis pour les thermostats radio / Non necessario per termostati radio / Não é necessário para termostatos rádio / Nicht erforderlich für Funk-Thermostate

- 2
- 3
- 4
- 5
- 6
- 7

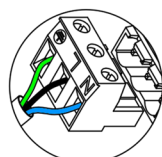
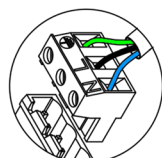
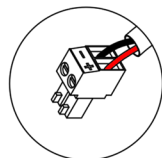
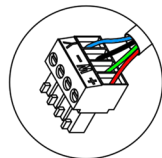
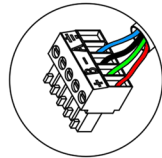
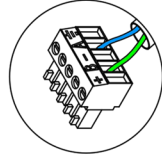

<b>A</b>	Y	Azul   Blue   Bleu   Blu   Azul   Blau
	-	Negro   Black   Noir   Nero   Negro   Schwarz
<b>B</b>	W	Verde   Green   Vert   Verde   Verde   Grün
	+	Rojo   Red   Rouge   Rosso   Vermelho   Rot

<b>N</b>	Neutro   Neutral   Neutro   Neutre   Neutro   Neutraleiter
<b>L</b>	Fase   Phase   Fase   Phase
	Tierra   Ground   Terra   Terra   Schutzleiter

— No necesario para termostatos radio / Not necessary for wireless thermostats / Non requis pour les thermostats radio / Non necessario per termostati radio / Não é necessário para termostatos rádio / Nicht erforderlich für Funk-Thermostate

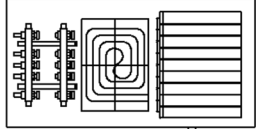

230 Vac  
F1  
F2

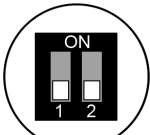
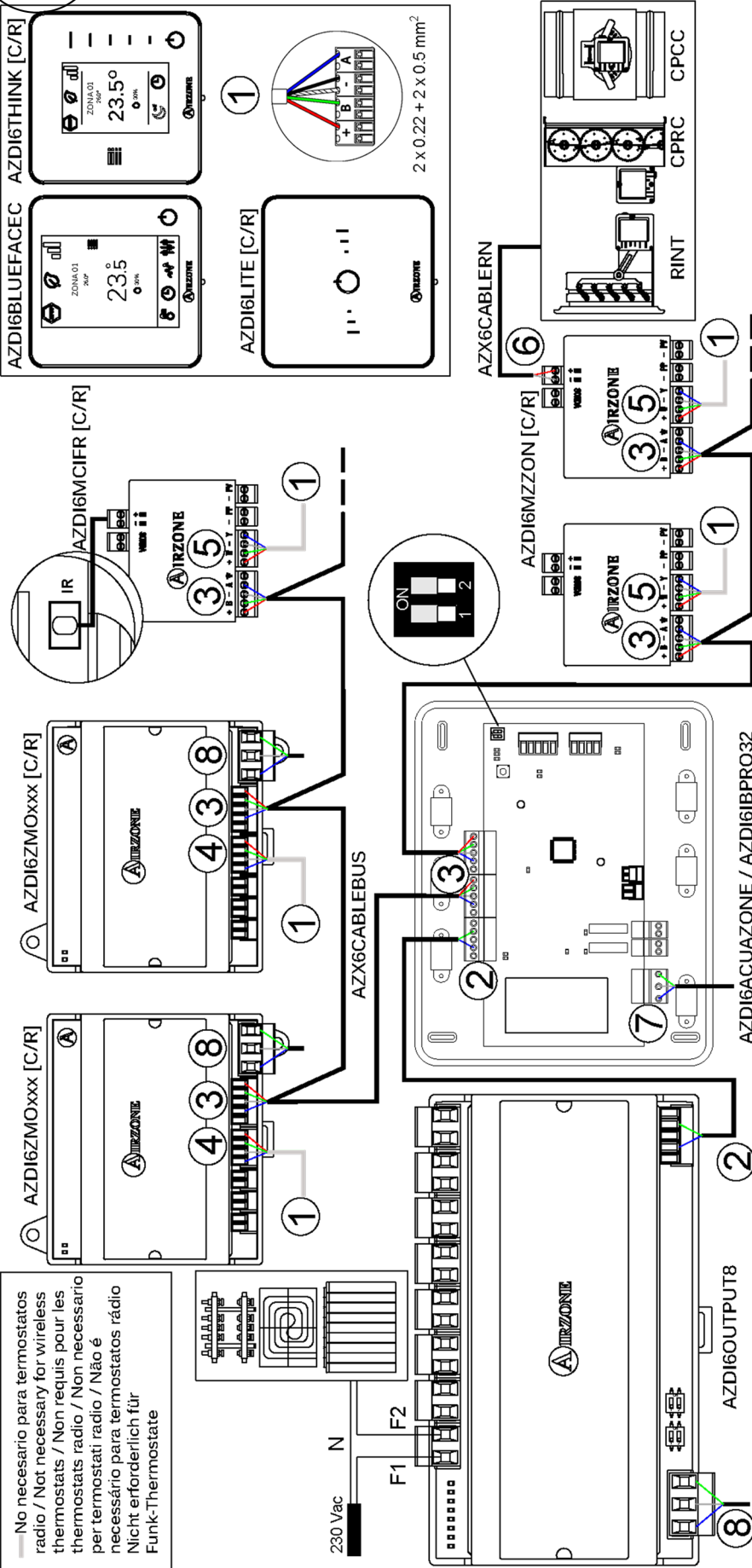

## MIXED CONFIGURATION

②

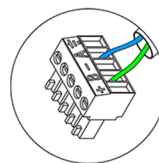

2 x 0.22 mm<sup>2</sup>

③

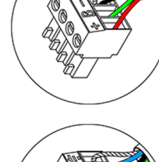

2 x 0.22 + 2 x 0.5 mm<sup>2</sup>

④

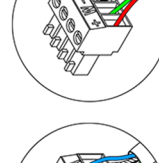

2 x 0.22 + 2 x 0.5 mm<sup>2</sup>

⑤

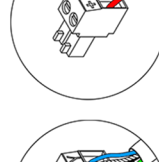

2 x 0.22 + 2 x 0.5 mm<sup>2</sup>

⑥

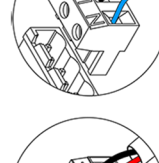

2 x 0.75 mm<sup>2</sup>

⑦

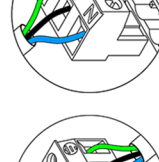

3 x 1.5 mm<sup>2</sup>

⑧



3 x 1.5 mm<sup>2</sup>

<b>A</b> Y	Azul   Blue   Azul   Bleu   Blu   Blau
-	Negro   Black   Negro   Noir   Nero   Schwarz
<b>B</b> W	Verde   Green   Verde   Vert   Verde   Grün
+	Rojo   Red   Vermelho   Rouge   Rosso   Rot
<b>N</b>	Neutro   Neutral   Neutro   Neutre   Neutro   Neutralleiter
<b>L</b>	Fase   Phase   Fase   Phase   Fase   Phase
	Tierra   Ground   Terra   Terra   Terra   Schutzleiter

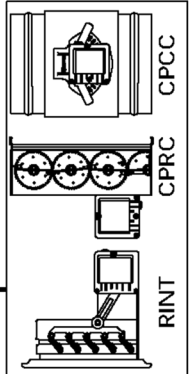

AZX6CABLERN

⑥

1

AZX6CABLERN

③

⑤

①

1

AZX6CABLERN

①

AZX6CABLERN

①

AZX6CABLERN

①

AZX6CABLERN

①

AZX6CABLERN

①

AZX6CABLERN

①

AZX6CABLERN

①

AZX6CABLERN

①

AZX6CABLERN

①

AZX6CABLERN

①

AZX6CABLERN

①

AZX6CABLERN

①

# 2-PIPES CONFIGURATION

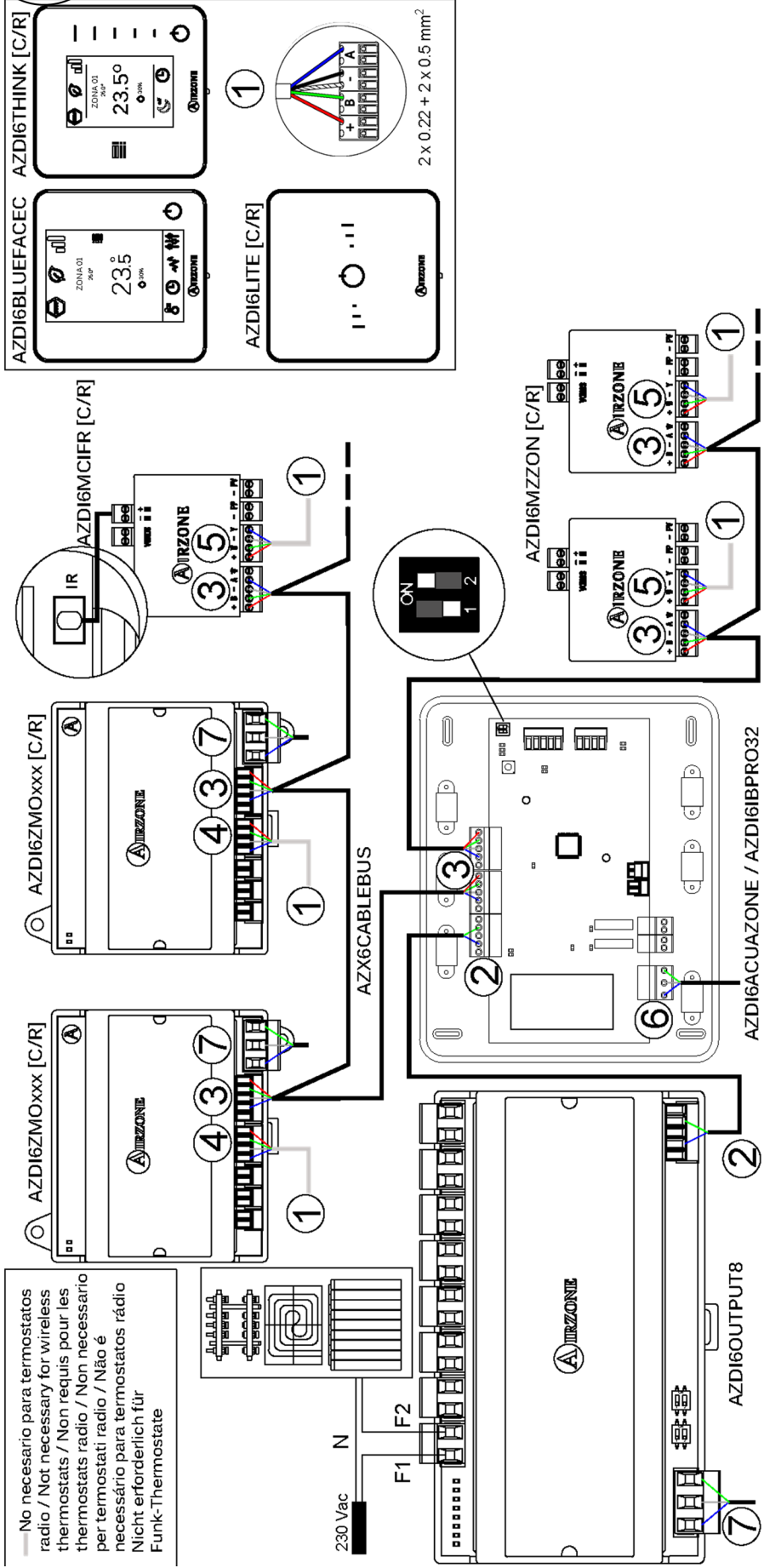
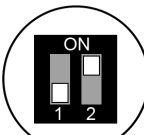

No necesario para termostatos radio / Not necessary for wireless thermostats / Non requis pour les thermostats radio / Non necessario per termostati radio / Não é necessário para termostatos rádio / Nicht erforderlich für Funk-Thermostate

<b>A</b> Y	Azul   Blue   Azul   Bleu   Blu   Blau
-	Negro   Black   Negro   Noir   Nero   Schwarz
<b>B</b> W	Verde   Green   Verde   Vert   Verde   Grün
+	Rojo   Red   Vermelho   Rouge   Rosso   Rot
<b>N</b>	Neutro   Neutral   Neutro   Neutre   Neutro   Neutralleiter
<b>L</b>	Fase   Phase   Fase   Phase   Fase   Phase
	Tierra   Ground   Terra   Terre   Terra   Schutzleiter

- ② 2 x 0.22 mm<sup>2</sup>
- ③ 2 x 0.22 + 2 x 0.5 mm<sup>2</sup>
- ④ 2 x 0.22 + 2 x 0.5 mm<sup>2</sup>
- ⑤ 2 x 0.22 + 2 x 0.5 mm<sup>2</sup>
- ⑥ 3 x 1.5 mm<sup>2</sup>
- ⑦ 3 x 1.5 mm<sup>2</sup>

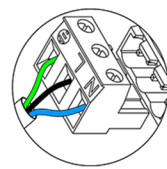
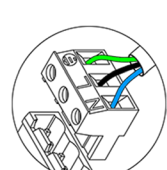
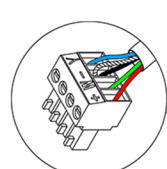
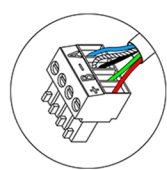
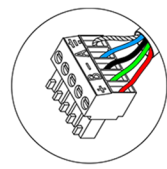
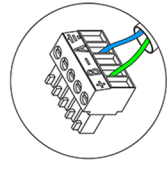



# 3/4-PIPES CONFIGURATION

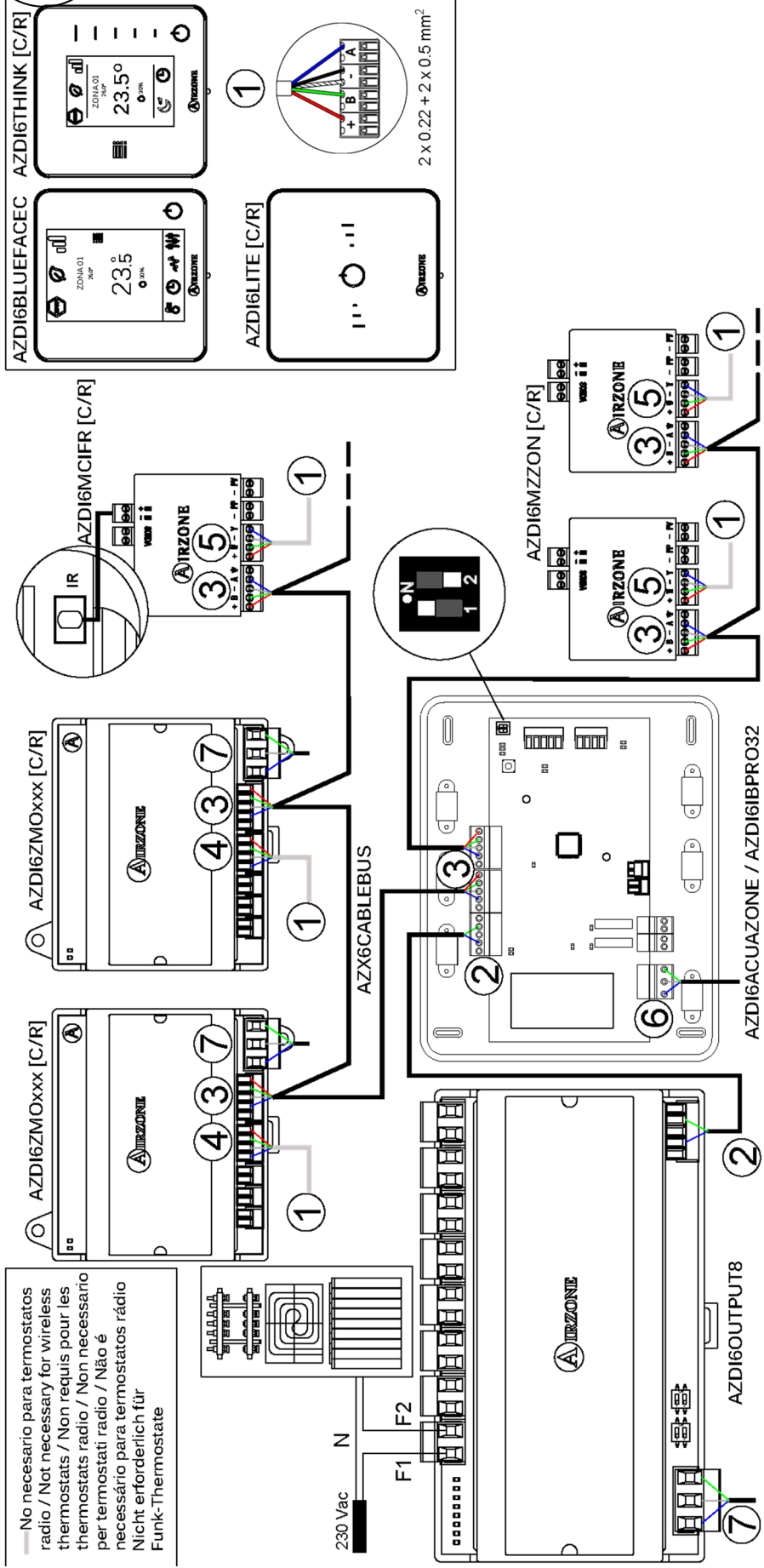
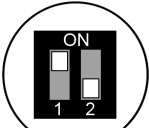

— No necesario para termostatos radio / Not necessary for wireless thermostats / Non requis pour les thermostats radio / Non necessario per termostati radio / Não é necessário para termostatos rádio / Nicht erforderlich für Funk-Thermostate

<b>A</b>	Y	Azul   Blue   Azul   Bleu   Blu   Blau
<b>-</b>		Negro   Black   Negro   Noir   Nero   Schwarz
<b>B</b>	W	Verde   Green   Verde   Vert   Verde   Grün
<b>+</b>		Rojo   Red   Vermelho   Rouge   Rosso   Rot
<b>N</b>		Neutro   Neutral   Neutro   Neutre   Neutro   Neutralleiter
<b>L</b>		Fase   Phase   Fase   Phase   Fase   Phase
		Tierra   Ground   Terra   Terre   Terra   Schutzleiter

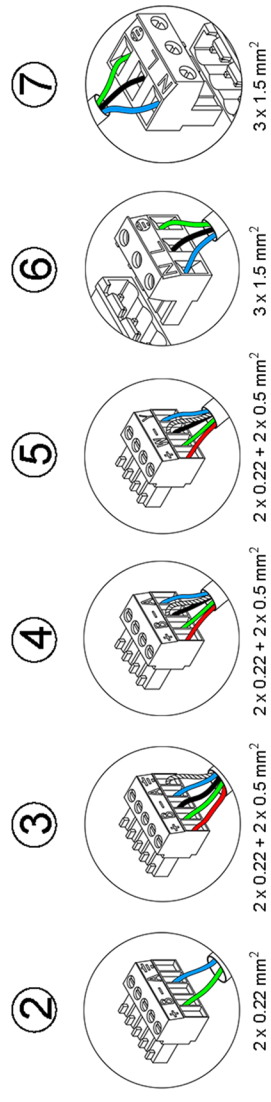

## INDEX

Warnings and environmental policy.....	10
Precautions.....	10
Environmental policy .....	10
System elements.....	11
Airzone Main control board (AZDI6ACUAZONE / AZDI6IBPRO32).....	11
Airzone Actuator zone module (AZDI6MZZON [C/R]).....	11
Airzone Electrical heating zone module (AZDI6MZSRE [C/R]) .....	11
Airzone Fancoil individual unit zone module Wired/Wireless (AZDI6ZMOFAN [C/R]) .....	12
Airzone individual unit zone module (AZDI6MC xxx [C/R]) .....	12
Airzone individual unit zone module (AZDI6ZMO xxx [C/R]) .....	12
Airzone infrared Individual unit zone module (AZDI6MCIFR [C/R]) .....	13
Airzone Control module of radiant elements (AZDI6OUTPUT8).....	13
Wall-embedded temperature probe (AZASONDTEMP) .....	13
Airzone Blueface color thermostat (AZDI6BLUEFACEC) .....	14
Airzone Think Monochrome thermostat Wired/Wireless (AZDI6THINK [C/R]) .....	14
Airzone Lite thermostat Wired/Wireless (AZDI6LITE [C/R]) .....	14
Airzone Communication Gateway (AZX6QADAPT xxx).....	15
Airzone Communication Gateway QAdapt 3 (AZX6QADAPT3 XXX) .....	15
Airzone Controller 3.0 Gateway (AZC6GTC XXX).....	15
Airzone 0-10 V Fancoil Control Gateway (AZX6010VOLTSZ).....	16
Fancoil control Gateway – 3 speeds (AZX6FANCOILZ) .....	16
Airzone Control Gateway for electromechanical units (AZX6ELECTROMECH).....	16
Webserver airzone cloud wi-fi dual 2.4-5G (AZX6WSC5GER) .....	17
Webserver Hub Airzone Cloud Dual (AZX6WSPHUB).....	17
Webserver Hub Airzone-BACnet (AZX6WSPBAC) .....	17
Webserver Hub Airzone-Lutron (AZX6WSPLUT) .....	18
Airzone Supermaster controller (AZX6CSMASTER [S/E] [B/G]) .....	18
Airzone Hidronic production control board (AZX6CCPGAWI).....	18
Airzone Production control board (AZX6CCP) .....	19
Airzone Aerothermal Gateway (AZX6GAW xxx) .....	19
KNX integration Gateway (AZXKNXGTWAY).....	19
Airzone temperature metallic probe in sheath (AZX6SONDPROTEC) .....	19
General requirements.....	20
Introduction.....	21
Types of systems .....	21
System installation.....	22
Assembly and connection.....	22
Airzone Main control board (AZDI6ACUAZONE / AZDI6IBPRO32).....	22
Assembly.....	22
Connection.....	23
Airzone Actuator zone module Wired/Wireless (AZDI6MZZON [C/R]) .....	26
Assembly.....	26
Connection.....	26
Airzone electrical heating zone module Wired/Wireless (AZDI6MZSRE [C/R]).....	27

Assembly .....	28
Connection .....	28
Airzone Fancoil Individual Unit zone module Wired/Wireless (AZDI6ZMOFAN [C/R]) .....	29
Assembly .....	29
Connection .....	30
Airzone Individual Unit zone module Wired/Wireless (AZDI6MC xxx [C/R]) .....	32
Assembly .....	32
Connection .....	32
Airzone Individual Unit zone module Wired/Wireless (AZDI6ZMO xxx [C/R]) .....	34
Assembly .....	34
Connection .....	34
Airzone Infrared Individual unit zone module Wired/Wireless (AZDI6MCIFR [C/R]) .....	35
Assembly .....	36
Connection .....	36
Airzone Control module of radiant elements (AZDI6OUTPUT8).....	37
Assembly .....	37
Connection .....	38
Airzone Wired Thermostats (AZDI6BLUEFACEC / AZDI6THINKC / AZDI6LITEC) .....	39
Assembly .....	39
Connection .....	39
Airzone Wireless thermostats (AZDI6THINKR / AZDI6LITER) .....	39
Assembly .....	39
Changing batteries.....	39
Airzone 0-10 V Fancoil control Gateway (AZX6010VOLTSZ) .....	40
Assembly .....	40
Connection .....	41
Airzone Control Gateway 3 Speeds Fancoil (AZX6FANCOILZ).....	42
Assembly .....	42
Connection .....	42
Airzone Control Gateway for electromechanical units (AZX6ELECTROMECH).....	43
Assembly .....	43
Connection .....	44
Webserver Airzone Cloud Wi-Fi dual 2.4-5G (AZX6WSC5GER) .....	45
Assembly .....	45
Connection .....	45
Configuration .....	46
Webserver HUB Airzone Cloud dual (AZX6WSPHUB).....	46
Assembly .....	46
Connection .....	46
Configuration .....	47
Webserver HUB Airzone BACnet (AZX6WSPBAC) .....	47
Assembly .....	48
Connection .....	48
Configuration .....	48
Webserver HUB Airzone-Lutron (AZX6WSPLUT) .....	49

Assembly .....	49
Connection .....	49
Configuration .....	50
Airzone Supermaster controller AZX6CSMASTER [S/E] [B/G] .....	51
Assembly .....	51
Connection .....	51
Airzone hydronic production control board (AZX6CCPGAWI) .....	52
Assembly .....	52
Connection .....	52
Airzone Production control board (AZX6CCP) .....	56
Assembly .....	56
Connection .....	56
KNX integration Gateway (AZX6KNXGTWAY) .....	60
Assembly .....	60
Connection .....	60
Assembly and connection evaluation .....	61
Secondary zones settings .....	61
Initial setup .....	61
Airzone Blueface and Airzone Think setup .....	62
Airzone Lite thermostats configuration .....	65
Reset Lite Thermostat .....	66
Initial Configuration evaluation .....	66
User and zone settings .....	66
User settings – Airzone Blueface thermostat .....	66
Zone settings – Airzone Blueface thermostats .....	67
User settings - Airzone Think thermostat .....	68
Advanced settings .....	68
System settings .....	69
Blueface .....	69
Think .....	70
Zone settings .....	70
Production Settings .....	72
Self-diagnose .....	74
Airzone Main control board (AZDI6ACUAZONE / AZDI6IBPRO32) .....	74
Airzone Wired/wireless Zoning Modules (AZDI6MZZON [C/R] and AZDI6MZSRE [C/R]) .....	75
Airzone Fancoil individual unit zone module wired/WIRELESS (AZDI6ZMOFAN [C/R]) .....	75
Wired/wireless gateway module (AZDI6MC xxx [C/R]) .....	76
Wired/wireless gateway module (AZDI6MC xxx [C/R]) .....	77
Airzone Infrared Gateway Module Wired/wireless (AZDI6MCIFR [C/R]) .....	77
Airzone Control module of radiant elements (AZDI6OUTPUT8) .....	78
Airzone Blueface and think thermostats (AZDI6BLUEFACEC / AZDI6THINK [C/R]) .....	79
Blueface and Think Thermostat Warnings .....	79
Blueface and Think Thermostats errors .....	79
Airzone Lite thermostats (AZDI6LITE [C/R]) .....	90
Airzone Communication gateways (AZX6QADAPT xxx) .....	94

Controller Gateway (AZX6GTC xxx) / Communication Gateway QAdapt 3 (AZX6QADAPT3 XXX) .....	95
Airzone 0-10 V Fancoil control Gateway (AZX6010VOLTSZ) .....	95
Airzone Control Gateway – 3 speeds fancoil (AZX6FANCOILZ).....	96
Airzone Control Gateway for electromechanical units (AZX6ELECTROMECH).....	96
Webserver Airzone Cloud (AZX6WEBSCLLOUDC/AZX6WSC5GER).....	97
Airzone hydronic production control board (AZX6CCPGAWI) .....	97
Airzone Production control board (AZX6CCP) .....	98
Airzone Aerothermal gateways (AZX6GAW xxx).....	98
Airzone-KNX Integration Gateway (AZX6KNXGTWAY) .....	100
Navigation trees.....	101
Navigation Tree - Blueface Thermostat.....	101
Navigation Tree - Think Thermostat.....	102

## WARNINGS AND ENVIRONMENTAL POLICY

### PRECAUTIONS

For your security, and to protect the devices, follow these instructions:

- Do not handle the system with wet or damp hands.
- Disconnect the power supply before making any connections.
- Take care not to cause a short circuit in any of the system connections.

### ENVIRONMENTAL POLICY



Do not dispose of this equipment in the household waste. Electrical and electronic equipment contain substances that may damage the environment if they are not handled appropriately. The symbol of a crossed-out waste bin indicates that electrical equipment should be collected separately from other urban waste. For correct environmental management, it must be taken to the collection centers provided for this purpose, at the end of its useful life.

The equipment's components may be recycled. Act in accordance with current regulations on environmental protection.

If you replace it with other equipment, you must return it to the distributor or take it to a specialized collection center.

Those breaking the law or by-laws will be subject to such purposes and measures as are laid down in environmental protection legislation.



## SYSTEM ELEMENTS

### AIRZONE MAIN CONTROL BOARD (AZDI6ACUAZONE / AZDI6IBPRO32)

Electronic board that controls the system through wired and wireless devices. Wall mounted.

Functionalities:

- Controls the status of the thermostats (up to 32 zones).
- Controls the proportionality and the minimum air supply of the dampers.
- Relay outputs for start-stop of AC unit and boiler (AZDI6ACUAZONE) or mechanical ventilation (CMV) (AZDI6IBPRO32).
- Control gateway management.
- Communication with units of integral control of the installation.
- Communications with other external control systems through integration bus.

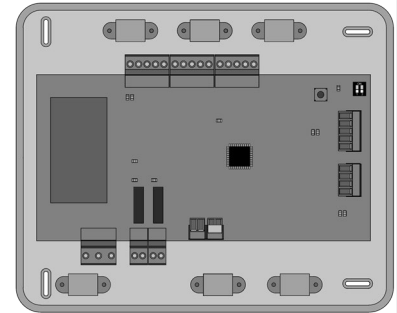

### AIRZONE ACTUATOR ZONE MODULE (AZDI6MZZON [C/R])

Local control module for controlling the opening-closing of the dampers. Wired or wireless communication to zone thermostats. Powered through Airzone Connection Bus.

Functionalities:

- Input for detection of open windows.
- Input for detection of presence.
- Probe input.
- Remote probe function and distributed probe function.
- Proportionality control and minimum air control of the dampers.

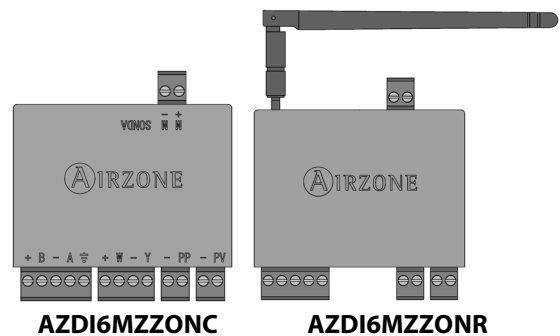

### AIRZONE ELECTRICAL HEATING ZONE MODULE (AZDI6MZSRE [C/R])

Local control module for controlling electrical heating elements and wired or wireless communication to zone thermostats. Powered through Airzone Connection Bus.

Functionalities:

- Input for detection of open windows.
- Input for detection of presence.
- Probe input.
- Remote probe function and distributed probe function.

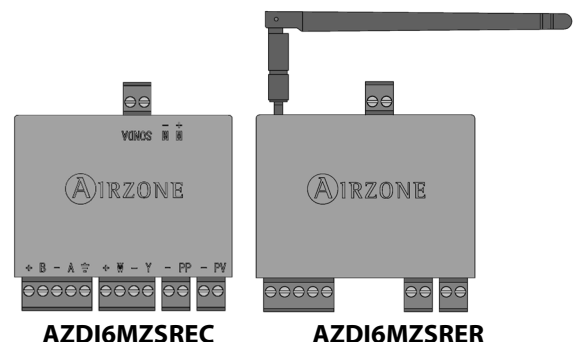

### AIRZONE FANCOIL INDIVIDUAL UNIT ZONE MODULE WIRED/WIRELESS (AZDI6ZMOFAN [C/R])

Local control module for air-to-water individual units. Control of fan speed and electrovalves for both 3 speeds and 0-10V units. Wired or Radio communications. Compatible with 2-pipe and 4-pipe installations. Externally powered at 110 / 230 Vac. Mounted on DIN rail.

Features:

- 2 relays for electrovalves control.
- 3 relays for up to 3 speeds control.
- 3 0-10V outputs to control the fan as well as cooling and heat valves.
- 3 digital inputs for detection of open windows, detection of presence and Eco function.
- 3 Analogic inputs for ambient as well as cold and heat batteries temperatura measurement.

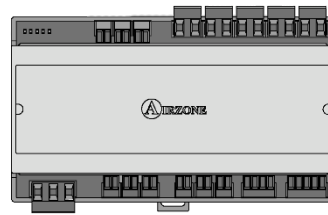

**AZDI6ZMOFANC**

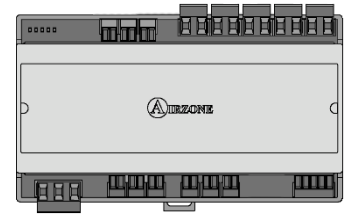

**AZDI6ZMOCFANR**

### AIRZONE INDIVIDUAL UNIT ZONE MODULE (AZDI6MC XXX [C/R])

Module for controlling direct expansion individual units through gateway. Wired or wireless communications with zone thermostat. Powered through Airzone Connection Bus. Mounted on DIN rail or on wall.

Functionalities:

- Input for detection of open windows.
- Input for detection of presence.
- Probe input.
- Remote probe function and distributed probe function.

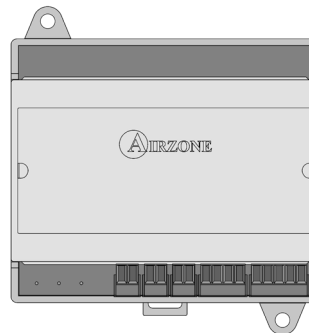

**AZDI6MCxxxC**

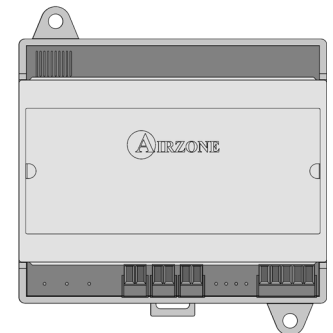

**AZDI6MCxxxR**

### AIRZONE INDIVIDUAL UNIT ZONE MODULE (AZDI6ZMO XXX [C/R])

Module for controlling direct expansion individual units through gateway. Wired or wireless communications with zone thermostat. Externally powered at 110/230 Vac. Mounted on DIN rail or on wall.

Functionalities:

- Input for detection of open windows.
- Input for detection of presence.
- Probe input.
- Remote probe function and distributed probe function.

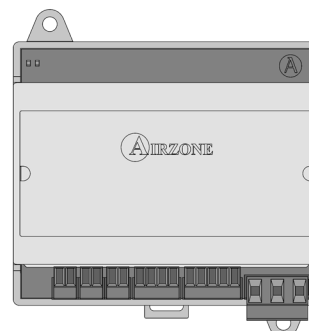

**AZDI6ZMOxxxC**

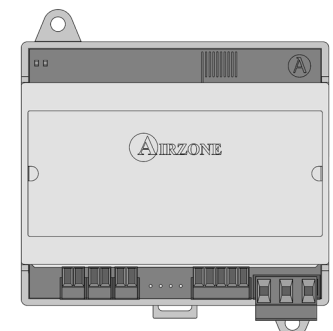

**AZDI6ZMOxxxR**

### AIRZONE INFRARED INDIVIDUAL UNIT ZONE MODULE (AZDI6MCIFR [C/R])

Local control module for controlling AC units via infrared. Wired or wireless communication to zone thermostats. Powered through Airzone Connection Bus.

Functionalities:

- Input for detection of open windows.
- Input for detection of presence.
- Probe input.
- Remote probe function and distributed probe function.

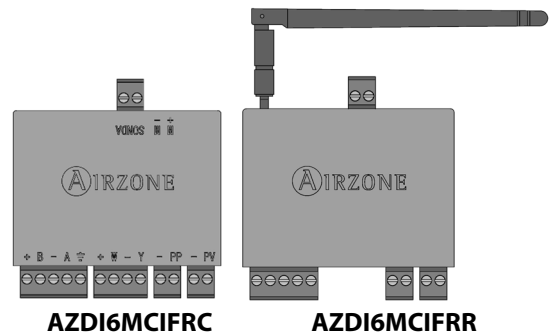

### AIRZONE CONTROL MODULE OF RADIANT ELEMENTS (AZDI6OUTPUT8)

Control module of radiant elements for cooling/heating/combined stages. Communications via Airzone Connection Bus of the Main Control Board. Externally powered at 110/230 Vac. Mounted on DIN rail.

Functionalities:

- Control of up to 8 radiant elements through 10-A relays at 110/230 Vac.
- Selection of board address through microswitch.
- Configurable as cooling/heating/combined through microswitch.

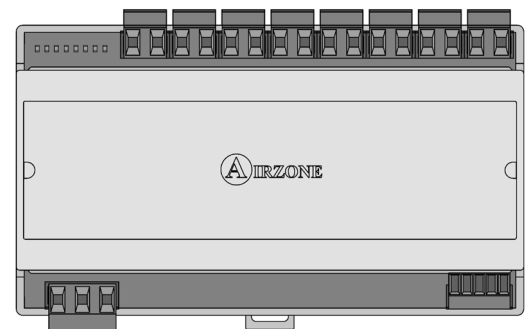

### WALL-EMBEDDED TEMPERATURE PROBE (AZASONDTEMP)

Temperature control probe for wall-embedded box. Mounted on universal mounting patterns.

Functionalities:

- Can be configured as remote or distributed probe.



## AIRZONE BLUEFACE COLOR THERMOSTAT (AZDI6BLUEFACEC)

Colour graphic interface with capacitive screen for controlling zones in Airzone systems. Powered by control module. Finished in steel and glass. Available in white or black.

Functionalities:

- Available in Spanish, English, French, Italian, German and Portuguese.
- Control of temperature, operating mode (Master thermostat) and system speed (depends on the type of installation).
- Room temperature and relative humidity measurement of the zone.
- Configuration stages control (air, radiant or combined).
- Eco-Adapt function.
- Sleep function.
- Temperature and mode time schedules.
- Remote access to other zones of the system.
- Weather forecast and AC unit consumption (optional).



## AIRZONE THINK MONOCHROME THERMOSTAT WIRED/WIRELESS (AZDI6THINK [C/R])

Graphic interface with low-energy e-ink screen and capacitive buttons for controlling zones in Airzone systems. Finished in steel and glass. Wired/Wireless communications. Powered through Control Module (cable) or by CR2450 button battery (wireless). Available in white or black.

Functionalities:

- Available in Spanish, English, French, Italian, German and Portuguese.
- Control of temperature, operating mode (Master thermostat) and system speed (depends on the type of installation).
- Room temperature and relative humidity reading.
- Sleep function.
- Remote access to other zones of the system.
- Weather forecast (optional).



## AIRZONE LITE THERMOSTAT WIRED/WIRELESS (AZDI6LITE [C/R])

Thermostat with capacitive buttons for controlling the temperature of the zones in Airzone systems. Wired/Wireless communications. Powered through control module (wired) or by CR2450 button battery (wireless). Available in white and black.

Functionalities:

- On/off of the zone.
- Set-point temperature control (accuracy:  $\pm 1^{\circ}\text{C}$ , up to a limit of  $\pm 3^{\circ}\text{C}$ .)
- Room temperature and relative humidity reading.



## AIRZONE COMMUNICATION GATEWAY (AZX6QADAPT XXX)

Element that fully integrates AC units and Airzone zoning systems, enhancing the performance of the installation:

- ON/OFF depending on the number of zones where there's demand.
- Automatic mode changeover (Stop, Ventilation, Cooling, Heating or Dry) from master thermostat.
- Automatic fan speed selection based on the number of zones on demand.
- Set-point temperature adjustment based on the set-point temperatures of the zone thermostats of the system and Eco Adapt algorithm.

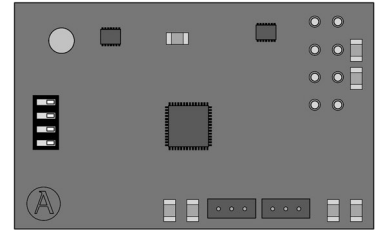

## AIRZONE COMMUNICATION GATEWAY QADAPT 3 (AZX6QADAPT3 XXX)

Gateway for the management of AC units compatible with Airzone control systems. Powered by the indoor unit. Assembly and connection on the AC unit bus of the enabled Airzone devices. Product developed and tested in collaboration with the manufacturer:

- Two-way communication of the basic control parameters depending on the demand of the Airzone control system.
- Adjustment of the set point temperature based on the selected temperatures in the Airzone thermostats and the Eco-Adapt algorithm.
- Reading of the operating temperature of the system.
- Reading of warnings and errors of the controlled unit.
- Secondary control of the unit.

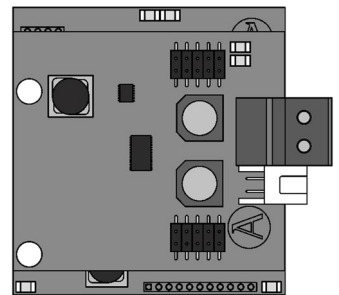

## AIRZONE CONTROLLER 3.0 GATEWAY (AZC6GTC XXX)

Gateway for the management of AC units compatible with Airzone control systems. Powered by the indoor unit. Assembly and connection on the AC unit bus of the enabled Airzone devices. Product developed and tested in collaboration with the manufacturer:

- Two-way communication of the basic control parameters depending on the demand of the Airzone control system.
- Adjustment of the set point temperature based on the selected temperatures in the Airzone thermostats and the Eco-Adapt algorithm.
- Reading of the operating temperature of the system.
- Reading of warnings and errors of the controlled unit.
- Master control of the unit.

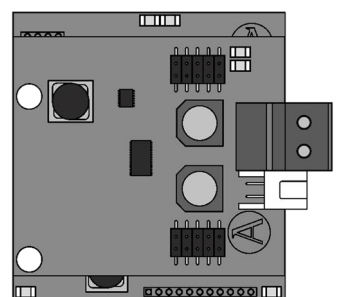

### AIRZONE 0-10 V FANCOIL CONTROL GATEWAY (AZX6010VOLT SZ)

Control gateway of air-to-water zoning units. Fan control through 0-10 V output and opening-closing electrovalves. Compatible with 2-pipe and 4-pipe installations. Externally powered at 110/230 Vac. Mounted on DIN rail or on wall.

Functionalities:

- Two relays for electrovalve control by demand.
- 0-10 V output for fan control.
- Automatic speed control based on the demand of the zones.

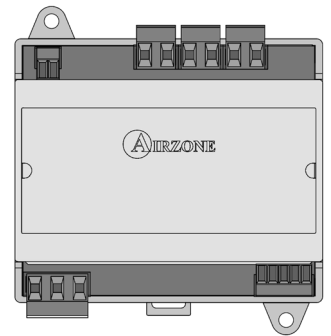

### FANCOIL CONTROL GATEWAY – 3 SPEEDS (AZX6FANCOILZ)

Control gateway for air-to-water air conditioners. Control of up to three fan-speeds and opening/closing of electro-valves. Compatible with 2 or 4-pipe air conditioners. Externally powered. Mounted on DIN rail or on wall.

Functionalities:

- Two electro-valve control relays for demand.
- Three control relays for fan-speed selection.
- Automatic fan speed selection based on the number of zones where there is demand.

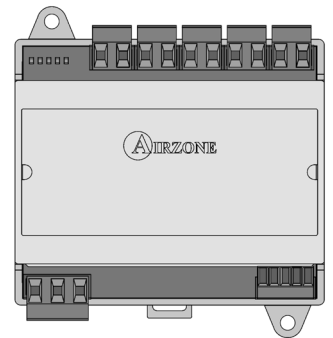

### AIRZONE CONTROL GATEWAY FOR ELECTROMECHANICAL UNITS (AZX6ELECTROMECH)

Control gateway for air-conditioning units with electromechanical control. Management of up to two compressors in 1 stage (balanced) or 2 stages. Powered through AC unit bus. Mounted on DIN rail or on wall.

Functionalities:

- Relay for fan control.
- Relay to control up to two compressors.
- Relays to control heating/cooling modes.
- Relay for boiler control.
- Two Airzone probe inputs for protection of production units.

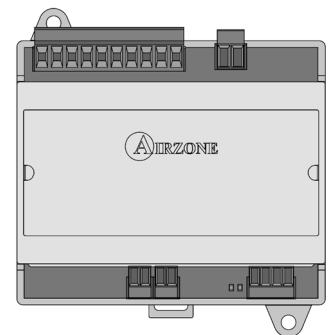



## WEBSERVER AIRZONE CLOUD WI-FI DUAL 2.4-5G (AZX6WSC5GER)

Webserver for controlling systems through Airzone Cloud platform. Accessible through browser or app (available for IOS and Android). Connection via Wi-Fi. Powered through domotic bus.

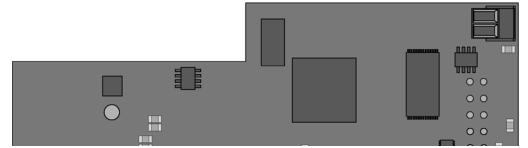

Functionalities:

- Control of up to 32 systems.
- Configuration and control of zone parameters (Room and set-point temp., operating mode, etc.) and system parameters via Airzone Cloud.
- Associated with router through the app via Bluetooth.
- Temperature and operating mode time schedules.
- Multi-user and multisession.
- External control through Airzone Cloud platform.
- Remote updates of the Webserver firmware and the systems connected to it.
- Remote error detection and error resolution.

## WEBSERVER HUB AIRZONE CLOUD DUAL (AZX6WSPHUB)

Webserver for controlling Airzone systems through Airzone Cloud platform. Accessible through browser or App (available for IOS and Android). Dual WiFi 2.4/5Ghz or Ethernet connection. Powered through domotic bus. Mounted on DIN rail or on wall.

Functionalities:

- Control of up to 32 systems.
- Configuration and control of zone parameters (Room and set-point temp., operating mode, etc.) and system parameters via Airzone Cloud.
- Associated with router through the app via Bluetooth.
- Multi-user and multisession.
- Port for integration via Modbus.
- Integration via local API.
- Remote updates of the Webserver firmware and the systems connected to it.
- Remote error detection and error resolution.

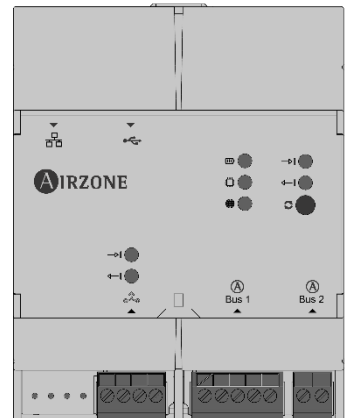

## WEBSERVER HUB AIRZONE-BACNET (AZX6WSPBAC)

Integration webserver for controlling Airzone installations through BACnet platform. Dual WiFi 2.4/5Ghz or Ethernet connection. Powered through domotic bus. Mounted on DIN rail or on wall.

Functionalities:

- One Airzone-BACnet webserver per installation.
- Status of window contact and presence contact of each zone.
- Status of the radiant stage of each zone.
- On/Off of each zone.
- Set-point temperature control of each zone.
- Operating mode status.
- State and Fancoil fan speed.

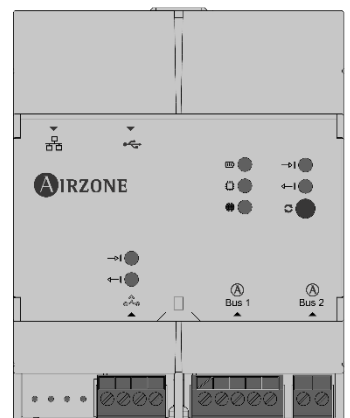

### WEBSERVER HUB AIRZONE-LUTRON (AZX6WSPLUT)

Integration webserver for Lutron control systems on Airzone systems through Lutron HomeWorks QS Processor. Dual WiFi 2.4/5Ghz or Ethernet connection. Powered through domotic bus. Mounted on DIN rail or on wall.

Functionalities:

- Reading/Writing of the room temperature.
- Reading/Writing of the set-point temperature.
- Reading/Writing of the operating mode.
- Reading/Writing of the cooling/heating demand.
- Reading/Writing of the fan speeds.

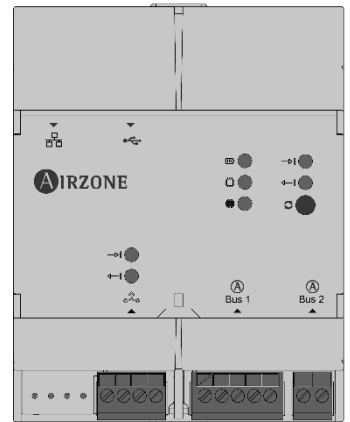

### AIRZONE SUPERMASTER CONTROLLER (AZX6CSMASTER [S/E] [B/G])

Monochrome LCD touch screen back-lighted controller for managing the system of the installation. Powered through AC unit bus. Wall-mounted (AZX6CSMASTERS) or wall-embedded (AZX6CSMASTERE). Available in white and grey.

Functionalities:

- Up to 8 control groups.
- Operating mode and set-point temperature control.
- Forced mode control: it imposes the operating mode and the temperature, blocking the user control.
- Semi-forced mode control: it imposes the mode range and the temperature every hour.
- Forced mode control: it imposes the operating mode and the temperature, blocking the control for the user.
- Temperature time schedule for the installation.
- Operating mode time schedules.

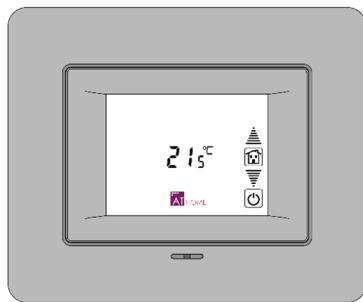

**AZX6CSMASTERE**

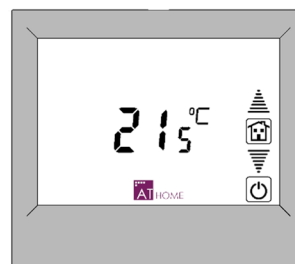

**AZX6CSMASTERS**

**Important:** This device is not compatible with the Production Control Board (AZX6CCP).

### AIRZONE HIDRONIC PRODUCTION CONTROL BOARD (AZX6CCPGAWI)

Control board of production units. Communications through domotic bus. Externally powered at 110/230 Vac. Wall mounted.

Functionalities:

- Controls up to 32 systems.
- 6 control relays for cooling/heating modes, cooling/heating air demand and cooling/heating radiant demand.
- Inputs for semi-forced modes and DHW control.

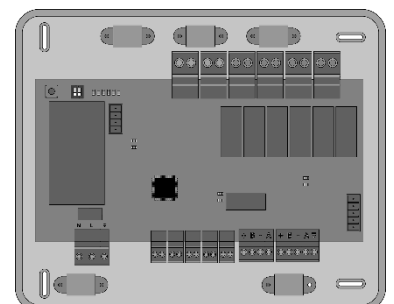

## AIRZONE PRODUCTION CONTROL BOARD (AZX6CCP)

Control board of production units through 6 relays of 10 A. Communications through domotic bus. Externally powered at 110/230 Vac. Wall mounted.

Functionalities:

- Controls up to 32 systems.
- Controls cooling and heating mode through 2 relays.
- Controls cooling air and the heating air demand through 2 relays.
- Controls the cooling and heating radiant element demand through 2 relays.
- 3 Inputs for semi-forced mode.
- Input for boiler probe.

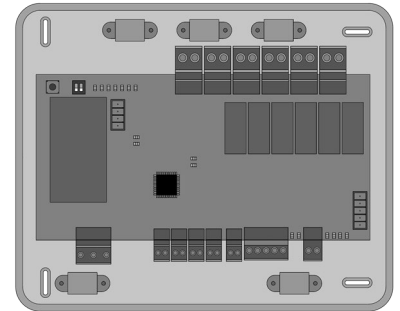

## AIRZONE AEROTHERMAL GATEWAY (AZX6GAW XXX)

Communication gateway for aerothermal units. Powered through the AC unit bus of the production control board (AZX6CCP / AZX6CCPGAWI).

Functionalities:

- Two-way communication of the basic control parameters depending on the demand of the Airzone control system.
- Reading of errors of the controlled unit.
- Imposes water production temperature based on the demand.

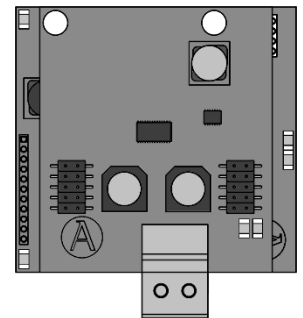

## KNX INTEGRATION GATEWAY (AZXKNXGTWAY)

Airzone integration gateway of HVAC systems into KNX TP-1 control systems through Modbus. Powered through KNX bus. DIN-rail mounting.

Functionalities:

- One Airzone system per KNX gateway.
- Full KNX.
- KNX standard data.
- Easily configurable from ETS.
- Zone control through KNX devices.
- Type of installation control.
- Communication errors detection.



## AIRZONE TEMPERATURE METALLIC PROBE IN SHEATH (AZX6SONDPROTEC)

Temperature probe in metal sheath.

Functionalities:

- Protection probe for return water (to boiler).
- Configurable as remote or distributed probe.



## GENERAL REQUIREMENTS

Strictly follow the directions outlined in this manual:

- This system must be installed by a qualified technician.
- Verify that the units to be controlled have been installed according to the manufacturer's requirements and operate correctly before installing the Airzone System.
- Locate and connect all the devices of the installation in accordance with the electronic regulations in force.
- Verify that the air conditioning installation to be controlled is in accordance with the regulations in force.
- It is necessary to use a Blueface Thermostat to have all the features of the Airzone system.
- To install the flexible duct, follow the local recommendations for its location and isolation of the ducts to the damper. Perform a cut along the isolated area to maintain the actuator of the damper outside it. Once finished, check the tightness of the joints between the damper and the duct.

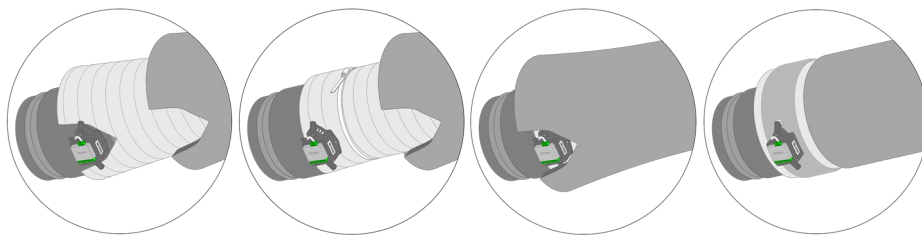

- On zones controlled by wireless controllers, place the dampers and zone modules as close as possible to the wireless controller of the zone.

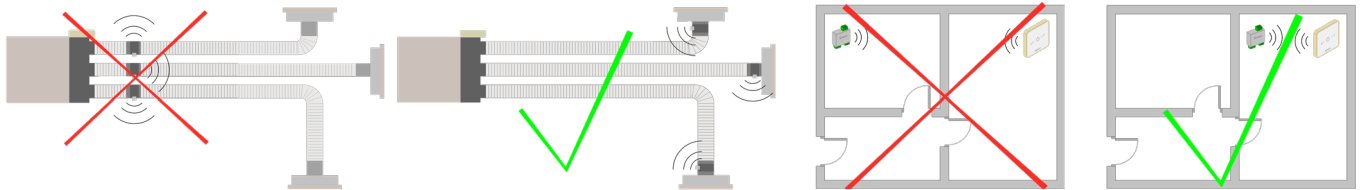

- Follow these recommendations to locate the thermostats:

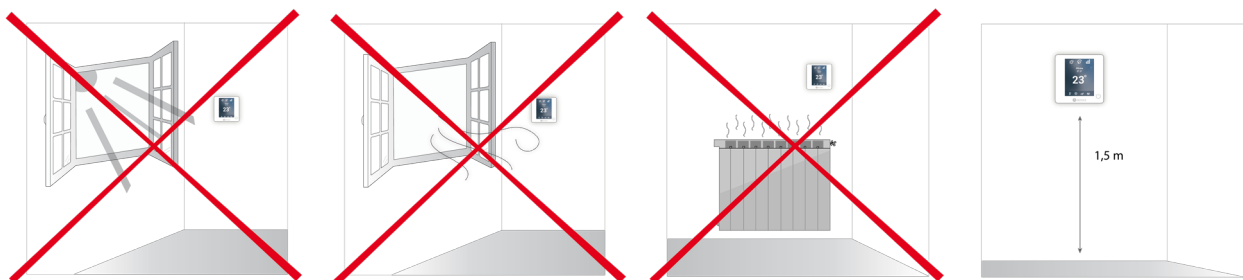

- Perform all the connections with total absence of power supply.
- In order to connect the elements of the system, use a proper cable: shielded twisted pair cable formed by 4 wires:  $2 \times 0,22 \text{ mm}^2 + 2 \times 0,5 \text{ mm}^2$  (AWG 20 – 4 wired). **The connection between the control modules must be made in Bus mode.**
- Do not place the system bus close to lines of force, fluorescent lights, LED lamps, motors, etc. It might cause interference on the communications.

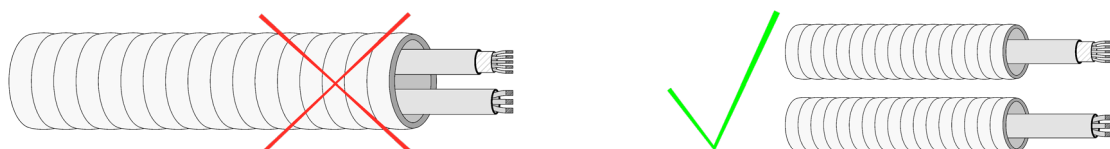

- Respect the connection polarity of each device. A wrong connection may seriously damage the product.
- For elements externally powered at 110 /230 Vac, for the communications, it is only necessary to connect the poles "A" and "B" of the bus.
- For elements externally powered at 110/230 Vac, respect the connection polarity. A wrong grounding may produce electric shocks.
- According to the current local and national regulations, it is mandatory to add a switch (or other element to disconnect the system) to the external supply wiring so that a constant separation between poles is guaranteed. The system will restart automatically if the supply is eventually turned off. **Use an independent circuit from the controlled system for the power supply.**
- Once the Airzone system is configured, verify that the static pressure of the duct system complies with the air distribution network conditions where is installed (check the Manufacturer’s Manual of the equipment if you need to modify this parameter).

## INTRODUCTION

Airzone systems enable the management of Master and Zone interfaces. Master thermostats enable mode management or define the efficiency level with the Eco-Adapt function.

**Remember:** This system only admits one Master thermostat.

To distinguish a Master Interface from a Zone Interface, check the next points:

- Blueface Master: Mode and Eco-Adapt in white color.
- Blueface Zone: Mode and Eco-Adapt in gray color.



## TYPES OF SYSTEMS

Configuration	Installation	Master thermostat
<b>Zoned</b>	Indoor zoned ducted AC unit (compatible with control of radiant elements)	One master thermostat per system
<b>Mixed</b>	Indoor zoned ducted AC unit and individual AC units (compatible with control of radiant elements)	One master thermostat per system
<b>2-pipe</b>	Individual AC units (compatible with control of radiant elements)*	One master thermostat per system
<b>3/4-pipe</b>	Individual AC units (compatible with control of radiant elements)*	Possibility of more than one Master per system

**\*Note:** AZDI6MZZON [C/R] Airzone actuator zone module can only control the radiant stage.

## SYSTEM INSTALLATION

Before the Airzone system commissioning, please check:

- The system to control works correctly without the Airzone system installed.
- In direct expansion unit systems, the indoor unit wired thermostat has been installed.

**Important:** For installations with radiant surfaces only, it is recommended the installation of buffer tanks.

In order to install properly your system, follow these steps:

- 1) **Configure the typology of your system**
  - Configure the microswitch of the main control board of the system (see paragraph *Types of systems*).
  - Configure the microswitches of the radiant element control module (check the technical sheet of this product).
- 2) **Make all connections** (see Section *Assembly and Connection*)
  - Connect the communication gateway.
  - Connect all the elements of the system (thermostats, modules, etc.).
  - Power the main control board.
- 3) **Check all the assembly and the connection are correct** (see section *Assembly and connection evaluation*)
- 4) **Configure the system**
  - Configure the secondary modules to associate them to a main thermostat.
  - Configure all the thermostats (see sections *Initial setup* and *Advanced settings*).

Access all our technical documents and the self-diagnosis section, check the most FAQs, certificates, watch our videos and read our declaration of conformity at: [myzone.airzone.es/products/](https://myzone.airzone.es/products/)

## ASSEMBLY AND CONNECTION

### AIRZONE MAIN CONTROL BOARD (AZDI6ACUAZONE / AZDI6IBPRO32)

#### Assembly

The production control board is supplied in a box to be screwed to the wall (Fig. 1). It should be placed and mounted in accordance with the current electrotechnical regulations.

For the mounting of the main control board, follow the following steps:

- Locate the control board close to the unit to be controlled.
- Unscrew the cover securing the back part to the wall.
- Make all the connections and screw the cover again.

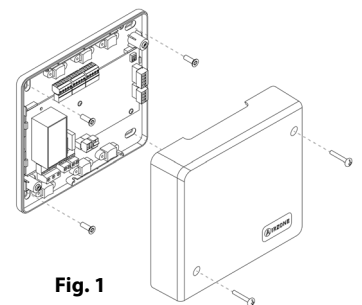

Fig. 1



## Connection

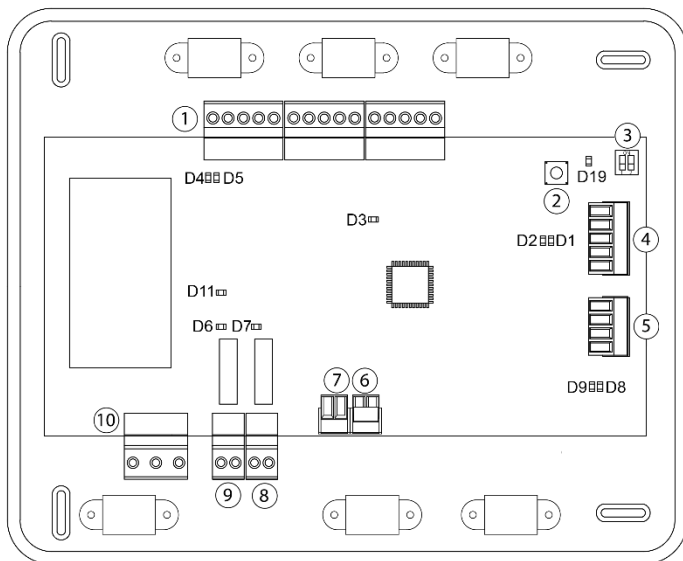

Fig. 2

No.	Description
1	Airzone Connection Bus
2	SW1
3	SW2
4	Automation bus
5	AC unit bus
6	Alarm input (normally closed)
7	Protection temperature probe
8	CMV/Boiler
9	AC Start-stop relay
10	Power supply

### Airzone Connection Bus connectors

The Airzone Connection Bus allows you to connect all the internal components that are independent from the main board to control up to 32 zones. These are the gateways that can be connected:

- Airzone actuator zone module (AZDI6MZZON [C/R]).
- Airzone electrical heating zone module (AZDI6MZSRE [C/R]).
- Airzone Infrared Individual unit zone module (AZDI6MCIFR [C/R]).
- Airzone individual unit module for Gateway (AZDI6MCxxx [C/R] / AZDI6ZMOxxx[C/R]).
- Airzone 3 speed Fancoil individual unit zone module (AZDI6ZMOFAN [C/R]).
- Airzone Control module of radiant elements (AZDI6OUTPUT8).

It has 3 5-pin terminals to connect the Airzone Connection Bus. Both star connection and bus connection are available. Attach the wires with the terminal screws following the color code (Fig. 3). For added security, secure the wires using the turrets (Fig. 4).

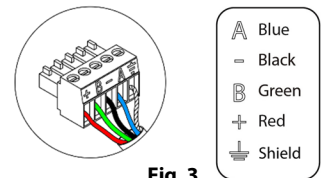

Fig. 3

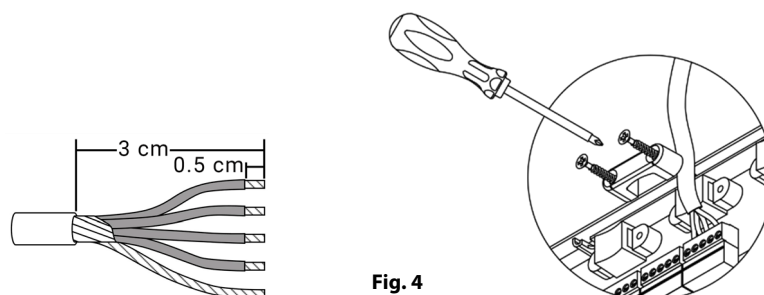

Fig. 4

### SW1

The main control board can also connect to Airzone wireless elements. These elements are associated by opening the wireless association module of the Main Control Board. Press on SW1 and wait for the LED 19 to remain red (Fig. 5). The wireless association module will be open during 15 minutes.

**System reset:** If you want to return to factory values, press and hold on SW1 (Fig. 5) until LED D19 stops blinking.

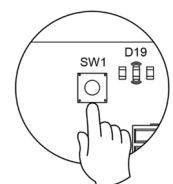

Fig. 5

## SW2

Configure the SW2 microswitch according with the type of system (see section *Types of systems*).

SW2		
2 Pipes	3/4 Pipes	Zoned / mixed

### Domotic bus connector

The domotic bus allows you to interconnect multiple systems in order to control them through Airzone control peripherals or to integrate them into a superior control network. These are the gateways that can be connected:

- Webserver Cloud (AZX6WEBSCLLOUD [C/R] and AZX6WSCLOUDDIN [C/R]).
- KNX integration gateway (AZXKNXGTWAY).
- BACnet Integration Gateway (AZX6BACNET).
- Production control board (AZX6CCP/AZX6CCPGAWI).
- Supermaster controller (AZX6CSMASTER [S-E])

It has a 5-pin terminal for the domotic bus connection. This system can only be connected by bus. Attach the wires with the terminal screws following the color code (Fig. 6).

*Note: For elements externally powered at 110/230 Vac, for the communications, it is only necessary to connect the poles "A", "B" and "Shield" of the communication bus. Use the shield only on the connector of the main control board.*

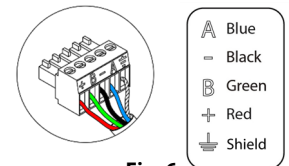

Fig. 6

### AC unit bus connector

The AC unit bus allows you to connect different control gateway to the AC unit. These are the gateways that can be connected:

- Communication gateways (AZX6QADAPT xxx / AZX6QADAPT3 xxx).
- Controller 3.0 Gateway (AZX6GTC xxx)
- 0-10 V communication gateway (AZX6010VOLT SZ).
- Electromechanical communication gateway (AZX6ELECTROME C).
- Fan coil communication gateway (AZX6FANCOIL Z).

It has a 4-pin terminal to connect the AC unit bus. The connection for these elements is point-to-point. Attach the wires with the terminal screws following the color code (Fig. 7).

*Note: For elements externally powered at 110/230 Vac, for the communications, it is only necessary to connect the poles "A", "B" and "Shield" of the communication bus.*

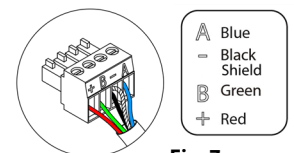

Fig. 7

To connect integrated gateways, disconnect the AC unit bus terminal and insert the connector and the fixing post of the gateway (Fig. 8).

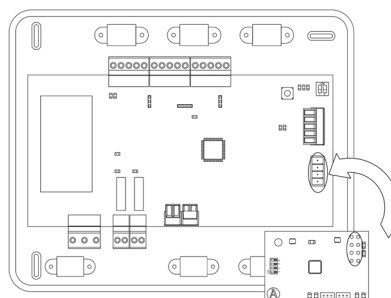

Fig. 8

### Alarm input

This input closes all the dampers and imposes Stop mode when there is an alert. This input is configured as normally closed. For proper operation of the system, this contact is supplied with a bonding jumper.

### Protection temperature probe connector

It measures the outdoor temperature through an external probe. We recommend the use of this probe when using electromechanical units or NON-Inverter units (when it is necessary to control the return temperature of the units).

### CMV/Boiler connector

This output can be configured as controlled mechanical ventilation control or boiler control. (See *Advanced setting, system setting*)

#### CMV configuration

Status	Stop	Ventilation	Air cooling	Cooling radiant	Air heating	Heating radiant
Demand ON	CMV OFF	CMV ON	CMV ON	CMV ON	CMV ON	CMV ON
Demand OFF	CMV OFF	CMV ON	CMV ON	CMV ON	CMV ON	CMV ON

#### Boiler configuration

Status	Stop	Ventilation	Air cooling	Cooling radiant	Air heating	Heating radiant
Demand ON	BOIL. OFF	BOIL. OFF	BOIL. OFF	BOIL. ON	BOIL. OFF	BOIL. ON
Demand OFF	BOIL. OFF	BOIL. OFF	BOIL. OFF	BOIL. OFF	BOIL. OFF	BOIL. OFF

Relay specs:  $I_{max} = 1$  A at 24/48 Vac, voltage-free. Note that to control elements with a greater power, it is recommended to use contactors in accordance with the power required.

### AC Start-stop relay

This output is develop to start-stop AC units. Logic of operation of the output:

Status	Stop	Ventilation	Air cooling	Cooling radiant	Air heating	Heating radiant
Demand ON	AC UNIT OFF	AC UNIT ON	AC UNIT ON	AC UNIT OFF	AC UNIT ON	AC UNIT OFF
Demand OFF	AC UNIT OFF	AC UNIT OFF	AC UNIT OFF	AC UNIT OFF	AC UNIT OFF	AC UNIT OFF

Relay specs:  $I_{max} = 1$  A at 24-48 Vac, voltage-free. Note that to control elements with a greater power, it is recommended to use contactors in accordance with the power required.

**Note:** In systems with a mixed configuration, demand is defined by the zones of the zoned AC unit (the one that controls the motorized elements). In systems with a zoned configuration or 2/4-pipe configuration, the air demand is defined by any zone.

### Power supply connector

This connector powers the main control board and all the elements connected to it. Externally powered at 110/110/230 Vac. It is connected through a 3-pin terminal. Attach the wires with the terminal screws following the color code. (Fig. 9). For added security, secure the wires using the turret (Fig. 10).

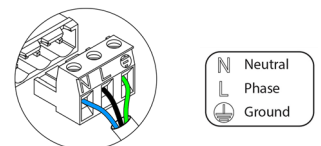

Fig. 9

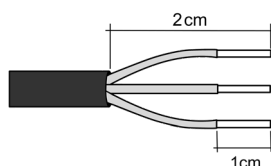
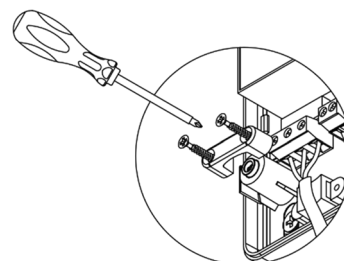

Fig. 10



**Important:** According to the current local and national regulations, it is mandatory to add a switch (or other element to disconnect the system) to the external supply wiring so that a constant separation between poles is guaranteed. The system will restart automatically if the supply is eventually turned off.

**Remember:** Once all the connections are made, make sure you replace the cover properly (Fig. 11).

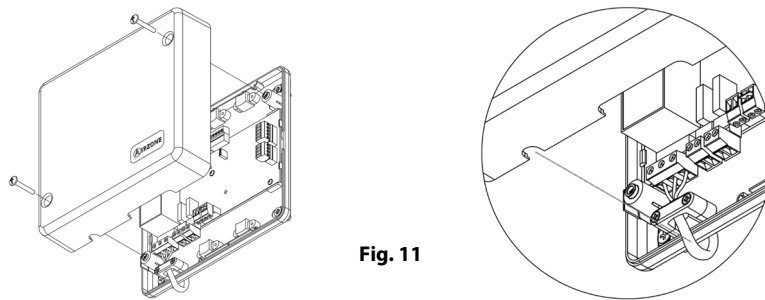

Fig. 11

### AIRZONE ACTUATOR ZONE MODULE WIRED/WIRELESS (AZDI6MZZON [C/R])

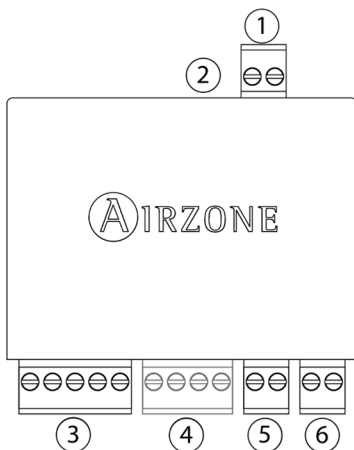

Fig. 12

N°	Meaning
1	Motorized element connector
2	Probe connector
3	Airzone Connection Bus
4	Thermostat connection ( <i>Only AZDI6MZZONC</i> )
5	Presence contact
6	Window contact

**Note:** Use a shielded twisted pair to connect the window contact.

#### Assembly

This module is designed to control the motorized elements of the system. **It is required to have one zoning module per motorized element.** Use the guideway to fix it to the motorized element to be controlled (Fig. 13).

#### Connection

The zoning module is a device that is connected to the Airzone Connection Bus of the main control board (Fig. 14).

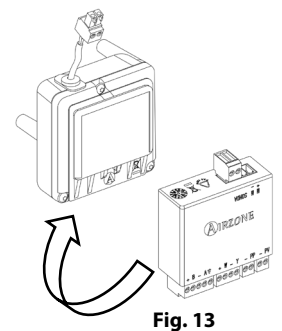

Fig. 13

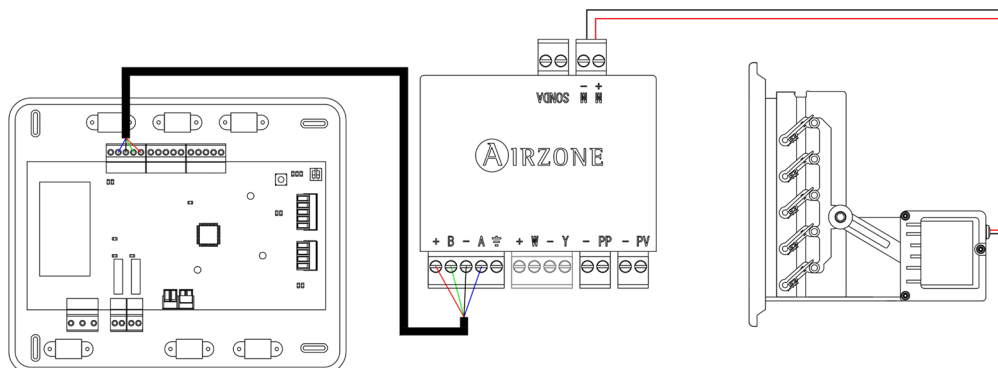

Fig. 14

It has a 5-pin terminal to connect it to the Airzone Connection Bus of the main board ③. Attach the wires with the terminal screws following the color code (Fig. 15).

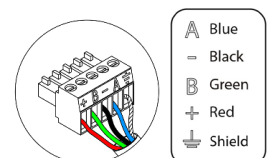

Fig. 15

- ④ It has a 4-pin terminal to connect the thermostat . Attach the wires with the terminal screws following the color code (Fig. 16).

**Remember:** The maximum separation between the module and the thermostat is 40 meters.

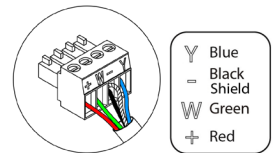

Fig. 16

- ① It is connected to the module through a 2-pin terminal. Attach the wires with the terminal screws following the color code (Fig. 17).

**Important:** It is not possible to connect more than one motorized elements to a single module.

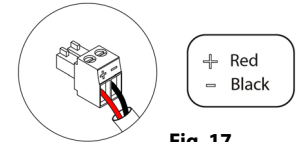

Fig. 17

The zoning module allows you to connect a probe (AZASONDTEMP / AZX6SONDPROTEC) for remote or distributed temperature reading, depending on how the module is configured:

- **Remote probe:** This function allows you to read the room temperature even if you are not where the thermostat is located. Connect the probe and configure the module as main module (connected thermostat). The state and the set-point temperature are set via thermostat while the probe reads the room temperature.  
**Note:** The thermostat won't display the relative humidity if using the remote probe.

- **Distributed probe:** This function allows you to control a subordinate zone with room temperature reading independent from the main zone. Connect the probe and configure the module as secondary (disconnected thermostat). The state and the set-point temperature are set via thermostat while the probe reads the room temperature.

The module has several inputs to control based on the occupancy or if there are open windows .

- ⑤ - **Control by occupancy:** When the occupancy sensor connected to the module indicates that the zone is unoccupied, the system waits for 5 minutes to confirm it is actually empty. After this period of time, the zone is set to Sleep Mode and it turns off after 90 minutes.
- ⑥ - **Control by open window:** When the open window sensor connected to the module indicates that a window is open for more than 60 seconds, the control element (actuator/relay) associated with that module closes.

The activation and configuration of these inputs are available in the zone settings menu of the thermostat (see *Advanced settings, Zone settings*).

## AIRZONE ELECTRICAL HEATING ZONE MODULE WIRED/WIRELESS (AZDI6MZSRE [C/R])

**Important:** This module is only compatible with Main Control Boards with version 4.2.0 or greater.

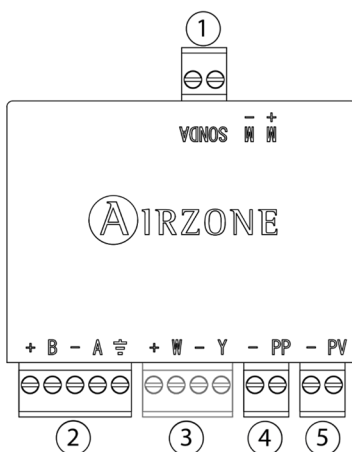

Fig. 18

N°	Meaning
①	Probe connector
②	Airzone connection bus
③	Thermostat connection (Only AZDI6MZSREC)
④	Presence contact
⑤	Window contact

**Note:** Use a shielded twisted pair to connect the window contact.

**Important:** It is necessary to have a Control Module of Radiant Elements (AZDI6OUTPUT8) to use the Airzone Electrical Heating Zone Module.

## Assembly

The zoning module is designed to control electrical heating elements. **It is required to have one zoning module per electric heating element of the system.** Screw the support platform to the wall and use the the guideway to fix it (Fig. 19).

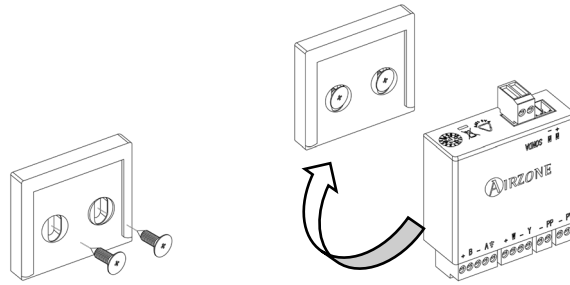

Fig. 19

## Connection

The zoning module is a device that is connected to the Airzone Connection Bus of the main control board (Fig. 20).

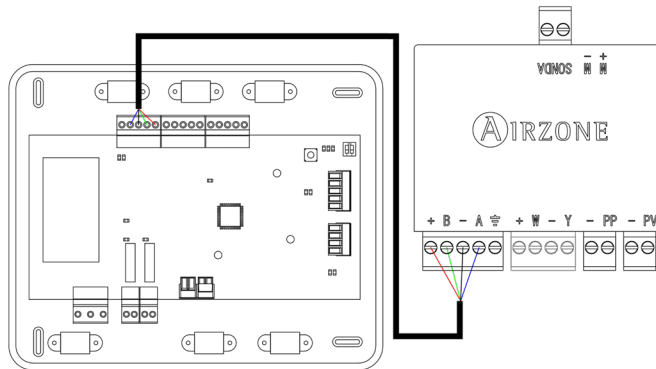

Fig. 20

- ② It has a 5-pin terminal to connect it to the Airzone Connection Bus of the main board . Attach the wires with the terminal screws following the color code (Fig. 21).
- ③ It has a 4-pin terminal to connect the thermostat . Attach the wires with the terminal screws following the color code (Fig. 22).

**Remember:** The maximum separation between the module and the thermostat is 40 meters.

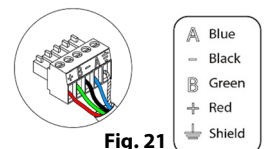

Fig. 21

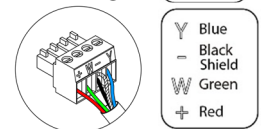

Fig. 22

The zoning module allows you to connect a probe ① (AZASONDTEMP / AZX6SONDPROTEC) for remote or distributed temperature reading, depending on how the module is configured:

**Remote probe:** This function allows you to read the room temperature even if you are not where the thermostat is located. Connect the probe and configure the module as main module (connected thermostat). The state and the set-point temperature are set via thermostat while the probe reads the room temperature.

- **Distributed probe:** This function allows you to control a subordinate zone with room temperature reading independent from the main zone. Connect the probe and configure the module as secondary (disconnected thermostat). The state and the set-point temperature are set via thermostat while the probe reads the room temperature.

The module has several inputs to control based on the occupancy ④ or if there are open windows ⑤.

- **Control by occupancy:** When the occupancy sensor connected to the module indicates that the zone is unoccupied, the system waits for 5 minutes to confirm it is actually empty. After this period of time, the zone is set to Sleep Mode and it turns off after 90 minutes.



- **Control by open window:** When the open window sensor connected to the module indicates that a window is open for more than 60 seconds, the control element (actuator/relay) associated with that module closes.

The activation and configuration of these inputs are available in the zone settings menu of the thermostat (See section *Advanced settings, Zone settings*).

### AIRZONE FANCOIL INDIVIDUAL UNIT ZONE MODULE WIRED/WIRELESS (AZDI6ZMOFAN [C/R])

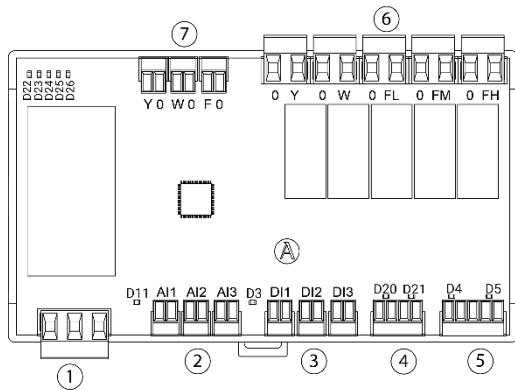

**Fig. 23**

**Note:** Use a shielded twisted pair to connect the window contact.

		Meaning	
①	Power supply		
②	/ Analog inputs	<b>AI1</b>	Temperature probe
		<b>AI2</b>	Cooling battery
		<b>AI3</b>	Heat battery
③	Digital inputs	<b>DI1</b>	Window contact
		<b>DI2</b>	Presence contact
		<b>DI3</b>	Eco function
④	Thermostat connection (Only available in AZDI6ZMOFANC)		
⑤	Airzone connection bus		
⑥	Fancoil control relays	<b>0 Y</b>	Cooling air demand
		<b>0 W</b>	Heating air demand
		<b>0 FL</b>	Speed 1
		<b>0 FM</b>	Speed 2
		<b>0 FH</b>	Speed 3
⑦	Outputs	<b>Y 0</b>	Cooling air demand
		<b>W 0</b>	Heating air demand
		<b>F 0</b>	Fan

### Assembly

The gateway module is mounted on DIN rail (Fig. 24). This module is externally powered at 110/230 Vac. It should be placed and mounted in accordance with the current electrotechnical regulations.

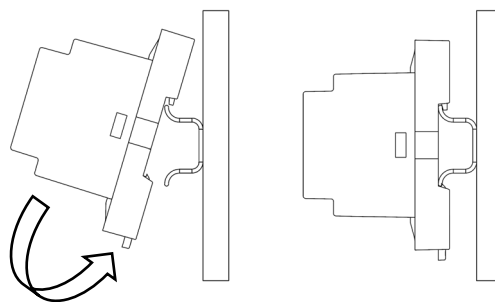

**Fig. 24**

**Note:** To remove the module on DIN rail, pull the tab down to release it.

### Connection

The Fancoil module is a device that is connected to the Airzone Connection Bus of the main control board. To connect speeds depending on the type of fancoil, check the following diagram. (Fig.26)

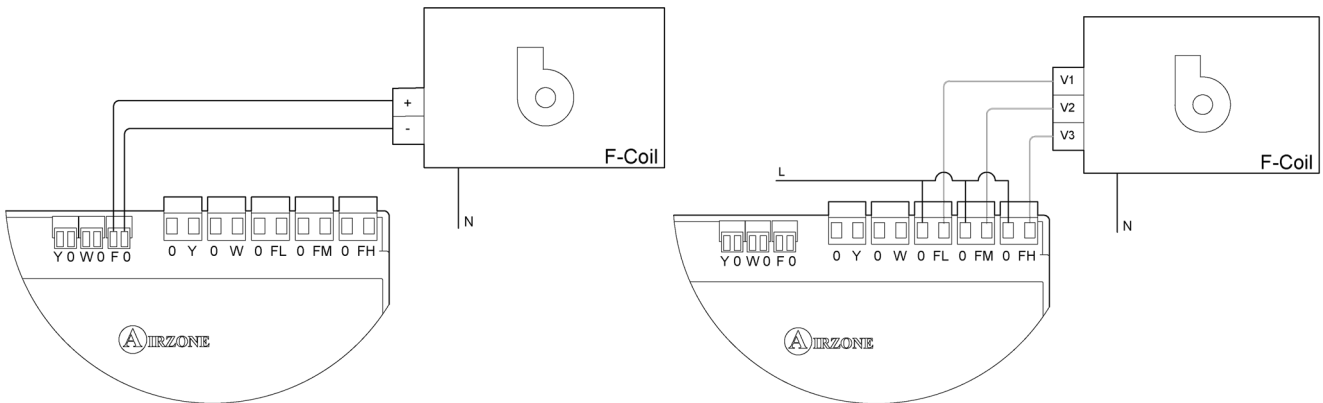

Fig.26

To connect Y/W (cooling/heating) modes depending on the type of fancoil, check the following diagram. (fig.27).

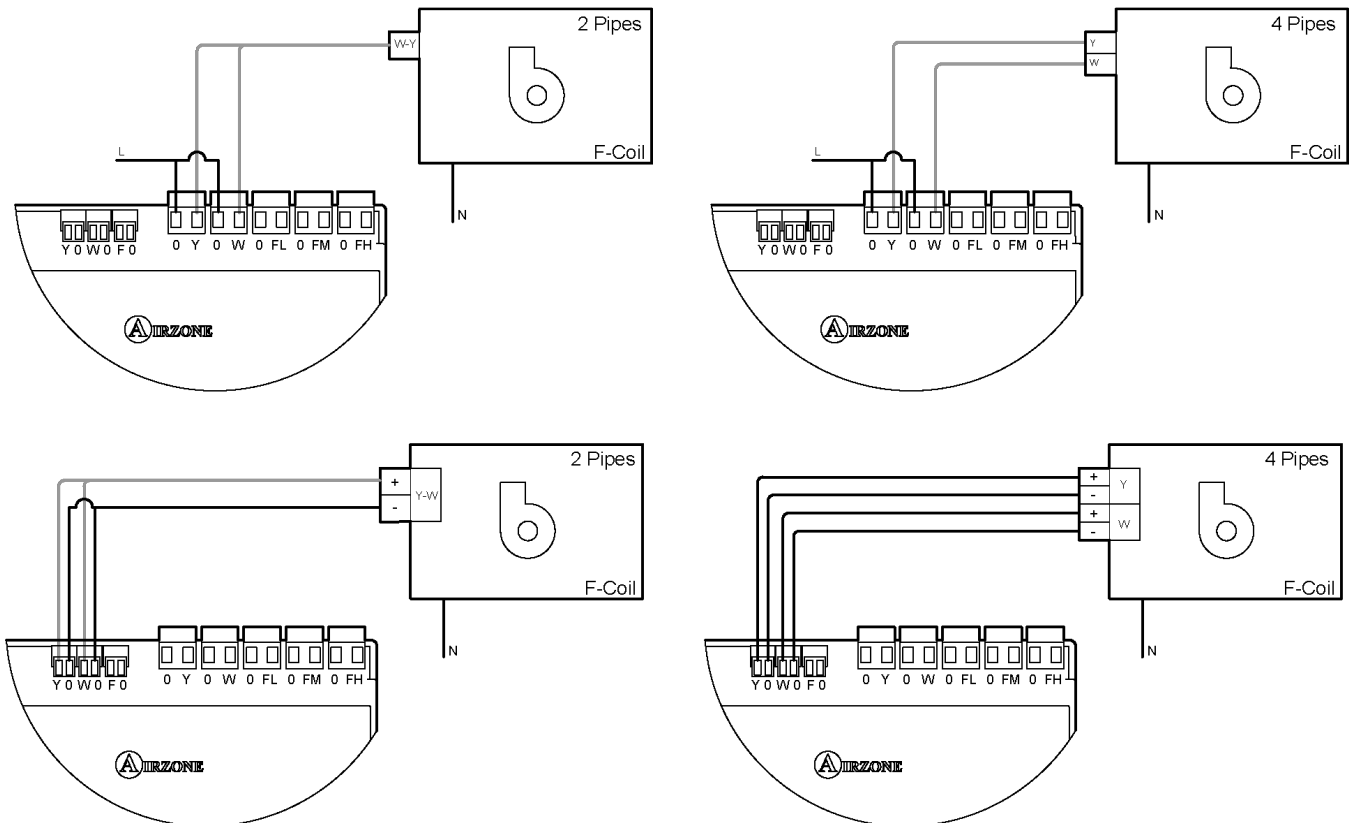

Fig.27

It has a 5-pin terminal to connect it to the Airzone Connection Bus of the main board <sup>⑤</sup>. Attach the wires with the terminal screws following the color code (Fig. 28).

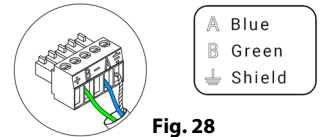

Fig. 28

It has a 4-pin terminal to connect the thermostat <sup>④</sup>. Attach the wires with the terminal screws following the color code (Fig. 29).

**Remember:** The maximum separation between the module and the thermostat is 40 meters.

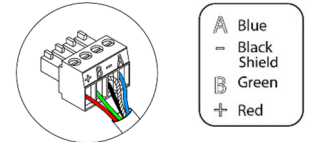

Fig. 29

It is connected to the module through a 3-pin terminal <sup>①</sup>. Attach the wires with the terminal screws following the color code (Fig. 30).

**Important:** According to the current local and national regulations, it is mandatory to add a switch (or other element to disconnect the system) to the external supply wiring so that a constant separation between poles is guaranteed. The system will restart automatically if the supply is eventually turned off.

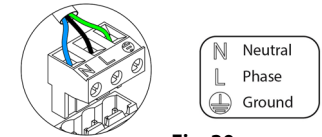

Fig. 30

The Fancoil gateway module allows you to connect a probe <sup>②</sup> (AZASONDTEMP / AZX6SONDPROTEC) for remote or distributed temperature reading, depending on how the module is configured:

- **Remote probe:** This function allows you to read the room temperature even if you are not where the thermostat is located. Connect the probe and configure the module as main module (connected thermostat). The state and the set-point temperature are set via thermostat while the probe reads the room temperature.
- **Distributed probe:** This function allows you to control a subordinate zone with room temperature reading independent from the main zone. Connect the probe and configure the module as secondary (disconnected thermostat). The state and the set-point temperature are set via thermostat while the probe reads the room temperature.

The module has 3 digital inputs to control based on the occupancy <sup>③</sup>, if there are open windows or through the ECO function.

- **Control by occupancy:** When the occupancy sensor connected to the module indicates that the zone is unoccupied, the system waits for 5 minutes to confirm it is actually empty. After this period of time, the zone is set to Sleep Mode and it turns off after 90 minutes.
- **Control by open window:** When the open window sensor connected to the module indicates that a window is open for more than 60 seconds, the control element (actuator/relay) associated with that module closes.
- **ECO Function:** It can be enabled through the digital input showed in the previous figure. When activated, ECO function will modify the setpoint temperature of the zone in 2.5 °C, this change will be an increment if the zone is working on Cool mode, or a decrease in case the zone is working on Heat mode. This change will be reflected on the thermostat's screen.

The activation and configuration of these inputs are available in the zone settings menu of the thermostat (see *Advanced settings, Zone settings*).

## AIRZONE INDIVIDUAL UNIT ZONE MODULE WIRED/WIRELESS (AZDI6MC XXX [C/R])

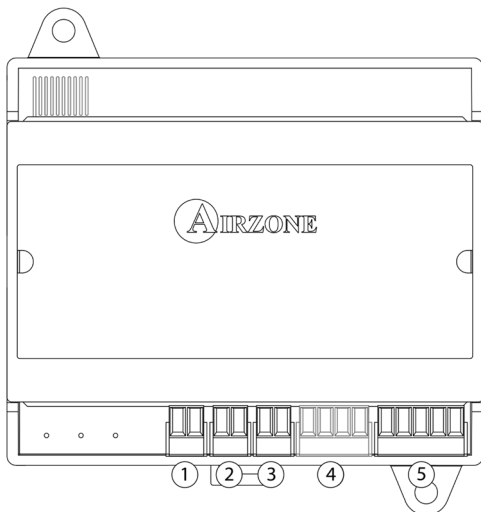

Fig.31

N°	Description
①	Probe Input
②	Window contact
③	Presence contact
④	Thermostat Connection ( <i>Only AZDI6MCxxxC</i> )
⑤	Airzone Connection Bus

**Note:** Use a shielded twisted pair to connect the window contact.

### Assembly

The gateway module is mounted on DIN rail (Fig. 32) or on wall (Fig. 33). It must be placed and mounted in accordance with the current electrotechnical regulations.

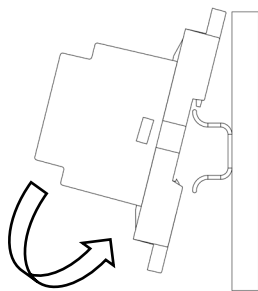

Fig. 32

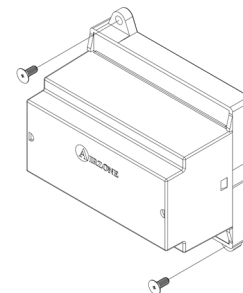
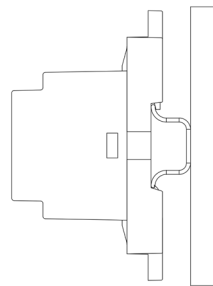

Fig. 33

**Note:** To remove the module on DIN rail, pull the tab down to release it.

### Connection

The gateway module is a device that is connected to the Airzone Connection Bus of the main control board (Fig. 34).

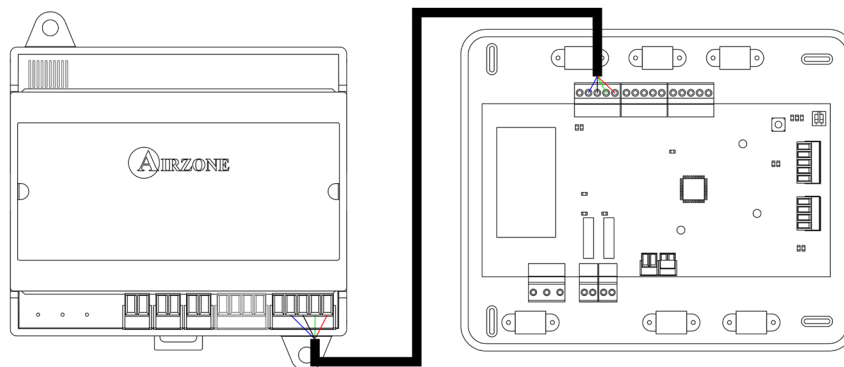

Fig. 34

It has a 5-pin terminal to connect it to the Airzone Connection Bus of the main board <sup>5</sup>. Attach the wires with the terminal screws following the color code (Fig. 35).

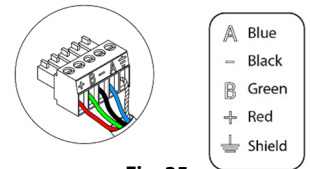

Fig. 35

It has a 4-pin terminal to connect the thermostat <sup>4</sup>. Attach the wires with the terminal screws following the color code (Fig. 36).

**Remember:** The maximum separation between the module and the thermostat is 40 meters.

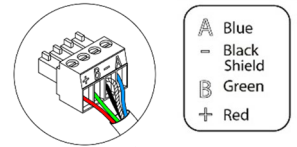

Fig. 36

The gateway module allows you to connect a probe (AZASONDTEMP / AZX6SONDPROTEC) for remote or distributed temperature reading, depending on how the module is configured:

- **Remote probe:** This function allows you to read the room temperature even if you are not where the thermostat is located. Connect the probe and configure the module as main module (connected thermostat). The state and the set-point temperature are set via thermostat while the probe reads the room temperature.  
**Note:** The thermostat won't display the relative humidity if using the remote probe.
- **Distributed probe:** This function allows you to control a subordinate zone with room temperature reading independent from the main zone. Connect the probe and configure the module as secondary (disconnected thermostat). The state and the set-point temperature are set via thermostat while the probe reads the room temperature.

The module has several inputs to control based on the occupancy or if there are open windows.

- **Control by occupancy:** When the occupancy sensor connected to the module indicates that the zone is unoccupied, the system waits for 5 minutes to confirm it is actually empty. After this period of time, the zone is set to Sleep Mode and it turns off after 90 minutes.
- **Control by open window:** When the open window sensor connected to the module indicates that a window is open for more than 60 seconds, the control element (actuator/relay) associated with that module closes.

The activation and configuration of these inputs are available in the zone settings menu of the thermostat (see *Advanced settings, Zone settings*).

## AIRZONE INDIVIDUAL UNIT ZONE MODULE WIRED/WIRELESS (AZDI6ZMO XXX [C/R])

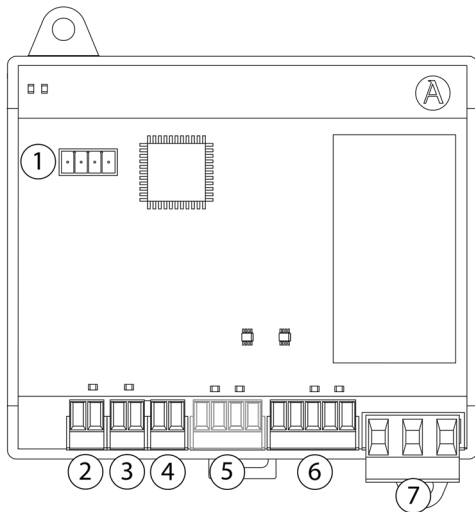

Fig.37

N°	Description
1	Gateway connection
2	Probe input
3	Window contact
4	Presence contact
5	Thermostat connection ( <i>Only AZDI6MCxxxC</i> )
6	Airzone connection bus
7	Power supply

**Note:** Use a shielded twisted pair to connect the window contact.

### Assembly

The gateway module is mounted on DIN rail (Fig. 38) or on wall (Fig. 39). It must be placed and mounted in accordance with the current electrotechnical regulations.

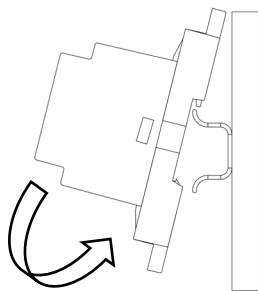

Fig. 38

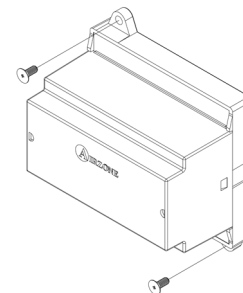
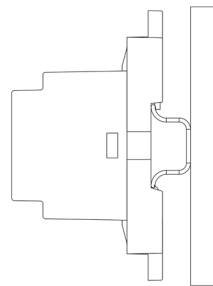

Fig. 39

**Note:** To remove the module on DIN rail, pull the tab down to release it.

### Connection

The gateway module is a device that is connected to the Airzone Connection Bus of the main control board (Fig. 40).

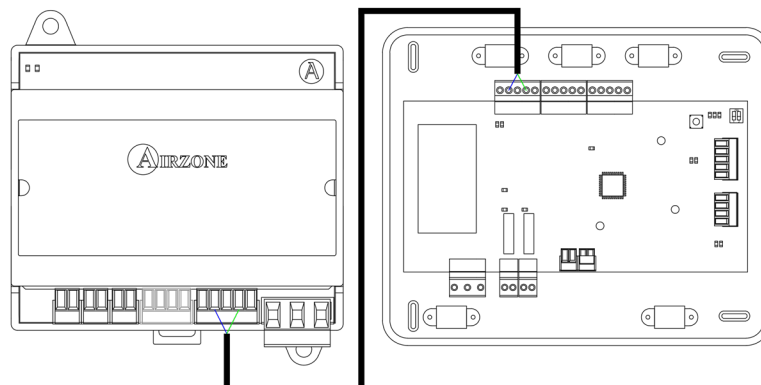
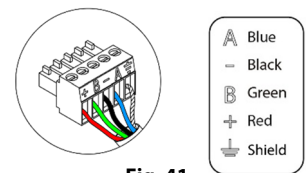

Fig. 40

It has a 5-pin terminal to connect it to the Airzone Connection Bus of the main board ⑥. Attach the wires with the terminal screws following the color code (Fig. 41).



It has a 4-pin terminal to connect the thermostat ⑤. Attach the wires with the terminal screws following the color code (Fig. 42).

**Remember:** The maximum separation between the module and the thermostat is 40 meters.

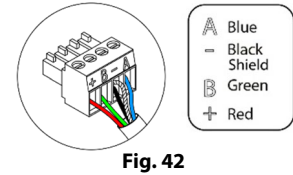

The gateway module allows you to connect a probe (AZASONDTEMP / AZX6SONDPROTEC) for remote or distributed temperature reading, depending on how the module is configured:

- **Remote probe:** This function allows you to read the room temperature even if you are not where the thermostat is located. Connect the probe and configure the module as main module (connected thermostat). The state and the set-point temperature are set via thermostat while the probe reads the room temperature.  
**Note:** The thermostat won't display the relative humidity if using the remote probe.
- **Distributed probe:** This function allows you to control a subordinate zone with room temperature reading independent from the main zone. Connect the probe and configure the module as secondary (disconnected thermostat). The state and the set-point temperature are set via thermostat while the probe reads the room temperature.

The module has several inputs to control based on the occupancy or if there are open windows.

- **Control by occupancy:** When the occupancy sensor connected to the module indicates that the zone is unoccupied, the system waits for 5 minutes to confirm it is actually empty. After this period of time, the zone is set to Sleep Mode and it turns off after 90 minutes.
- **Control by open window:** When the open window sensor connected to the module indicates that a window is open for more than 60 seconds, the control element (actuator/relay) associated with that module closes.

The activation and configuration of these inputs are available in the zone settings menu of the thermostat (see *Advanced settings, Zone settings*).

## AIRZONE INFRARED INDIVIDUAL UNIT ZONE MODULE WIRED/WIRELESS (AZDI6MCIFR [C/R])

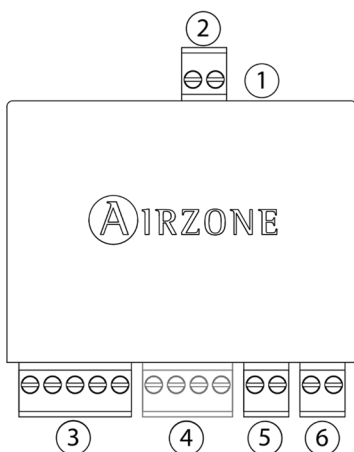

**Fig.43**

N°	Meaning
①	Connector IR
②	Probe connector
③	Airzone Connection Bus
④	Thermostat Connection ( <i>Only AZDI6MCIFRC</i> )
⑤	Presence contact
⑥	Window contact

**Note:** Use a shielded twisted pair to connect the window contact.

## Assembly

The infrared gateway module is designed to control individual split units. **It is required to have one infrared gateway module per motorized element.** They include a double-sided adhesive tape to simplify its mounting (Fig. 44).

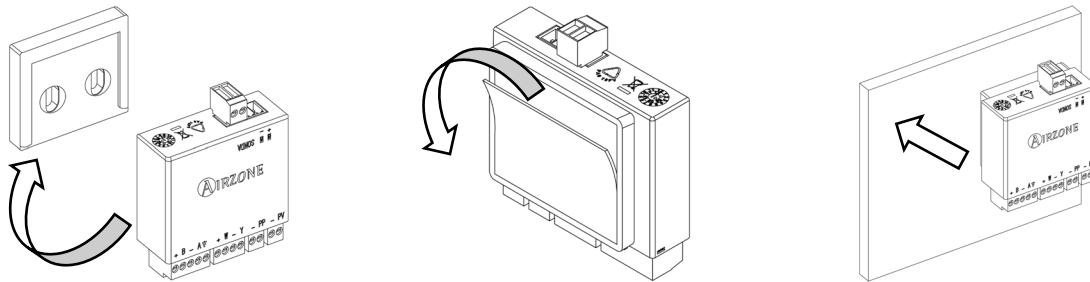

Fig.44

## Connection

The infrared gateway module is a device that is connected to the Airzone Connection Bus of the main control board (Fig. 45).

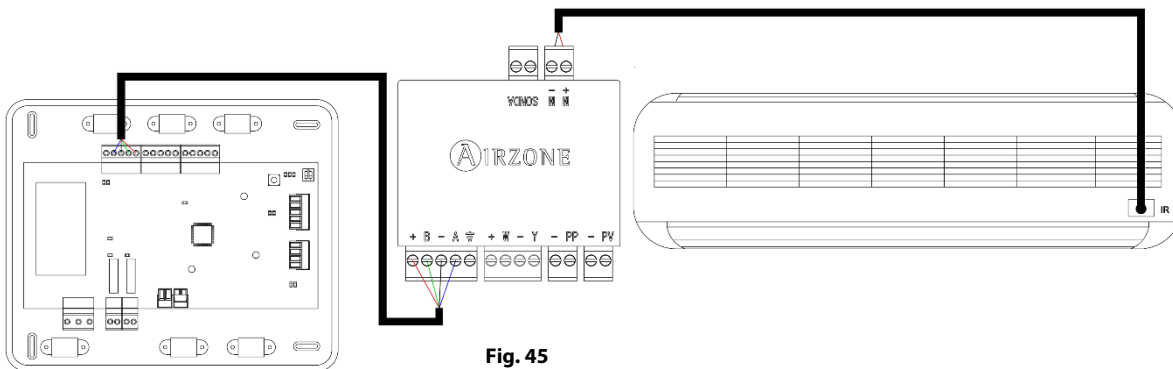

Fig. 45

It has a 5-pin terminal to connect it to the Airzone Connection Bus of the main board <sup>③</sup>. Attach the wires with the terminal screws following the color code (Fig. 46).

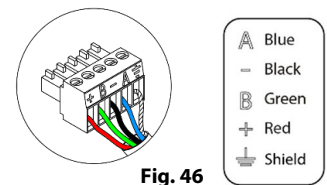

Fig. 46

It has a 4-pin terminal to connect the thermostat <sup>④</sup>. Attach the wires with the terminal screws following the color code (Fig. 47).

**Remember:** The maximum separation between the module and the thermostat is 40 meters.

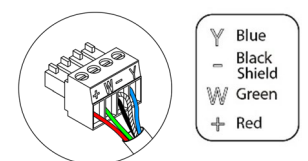

Fig. 47

The IR emitter is connected through a 2-pin terminal <sup>①</sup>. Attach the wires with the terminal screws following the color code (Fig. 48).

To connect the IR emitter to the split unit, remove the adhesive and secure the IR emitter in the IR receiver of the unit (Fig. 49).

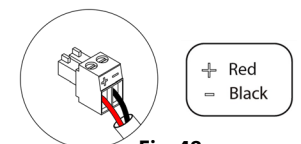

Fig. 48

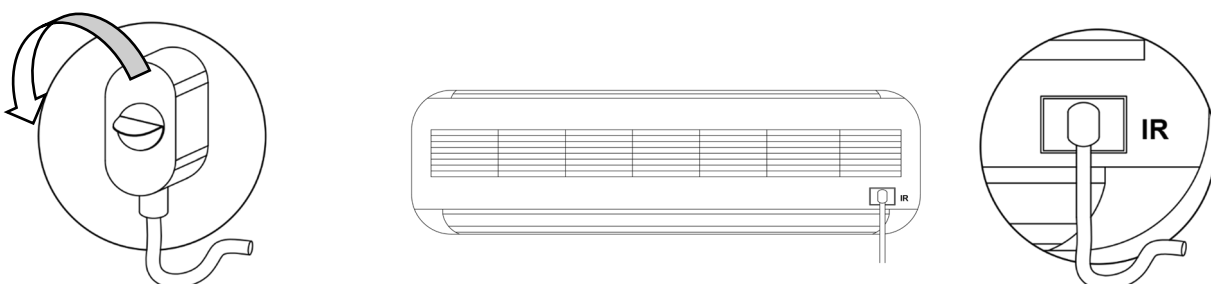

Fig. 49



The zoning module allows you to connect a probe ② (AZASONDTEMP / AZX6SONDPROTEC) for remote or distributed temperature reading, depending on how the module is configured:

- **Remote probe:** This function allows you to read the room temperature even if you are not where the thermostat is located. Connect the probe and configure the module as main module (connected thermostat). The state and the set-point temperature are set via thermostat while the probe reads the room temperature.  
**Note:** The thermostat won't display the relative humidity if using the remote probe.
- **Distributed probe:** This function allows you to control a subordinate zone with room temperature reading independent from the main zone. Connect the probe and configure the module as secondary (disconnected thermostat). The state and the set-point temperature are set via thermostat while the probe reads the room temperature.

The module has several inputs to control based on the occupancy or if there are open windows.

- **Control by occupancy:** When the occupancy sensor connected to the module indicates that the zone is unoccupied, the system waits for 5 minutes to confirm it is actually empty. After this period of time, the zone is set to Sleep Mode and it turns off after 90 minutes.
- **Control by open window:** When the open window sensor connected to the module indicates that a window is open for more than 60 seconds, the control element (actuator/relay) associated with that module closes.

The activation and configuration of these inputs are available in the zone settings menu of the thermostat (see *Advanced settings, Zone settings*).

## AIRZONE CONTROL MODULE OF RADIANT ELEMENTS (AZDI6OUTPUT8)

### Assembly

The control module of radiant elements (AZDI6OUTPUT8) is mounted on DIN rail (Fig. 50). This module is externally powered at 110/230 Vac. It should be placed and mounted in accordance with the current electrotechnical regulations.

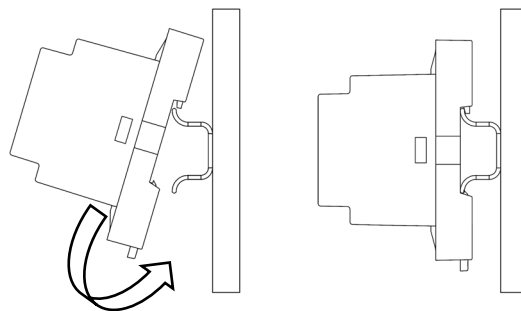

Fig. 50

**Note:** To remove the module, pull the tab down to release it.

## Connection

The control module of radiant elements is a device that connects to the Airzone Connection Bus of the main board (Fig. 51).

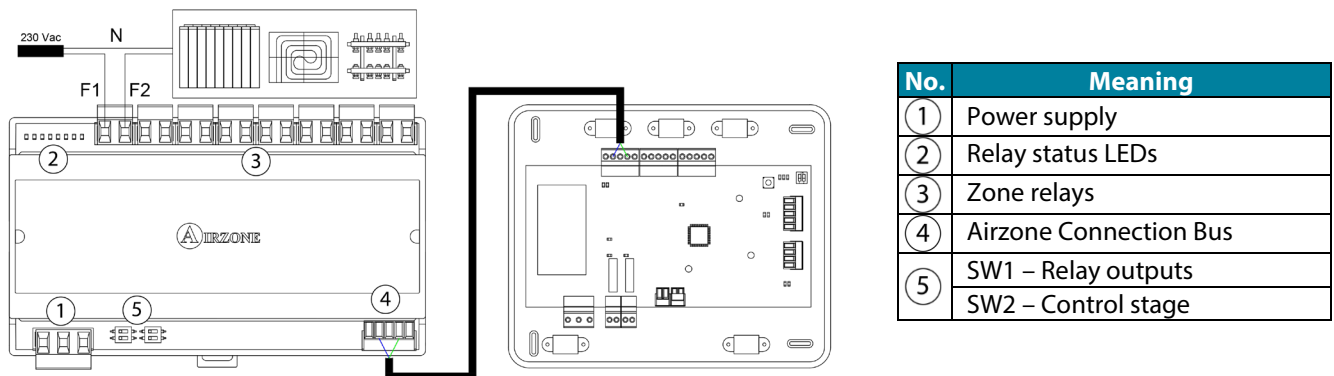
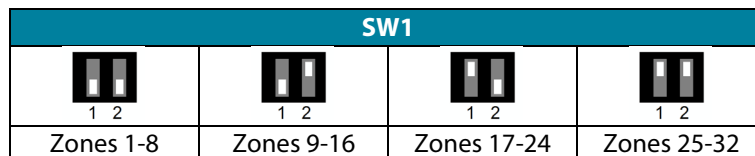

Fig. 51

The characteristics of the control relays are  $I_{max}$ : 10 A at 110/230 Vac (tension-free).

Note that to control elements with a greater power, it is recommended to use contactors in accordance with the power required. Remember to connect the neutral connector directly from the circuit to the element to be controlled.

The SW1 microswitch (zone address) is configured as follows:



**For example:** The control module of radiant elements that controls the zone with address 10 is the control module of radiant elements with addresses from 9-16.

The SW2 microswitch (logic of operation) is configured as follows:

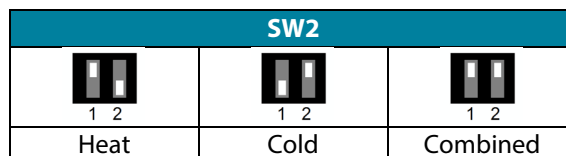

**Note:** If you want to reconfigure the SW2 microswitch, reset the module. To do this, remove the power supply for at least 10 seconds and reconnect it.

It has a 5-pin terminal to connect it to the Airzone Connection Bus of the main board ④. Attach the wires with the terminal screws following the color code (Fig. 52).

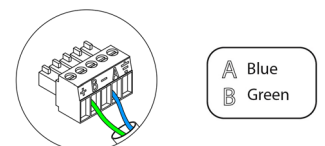

Fig. 52

It is connected to the module through a 3-pin terminal ①. Attach the wires with the terminal screws following the color code (Fig. 53).

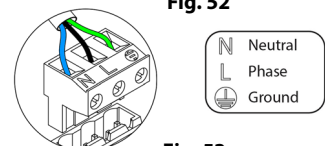

Fig. 53

Once supplied, the control module of radiant elements performs a sequential opening-closing of all relay outputs. This operation is repeated once a week to ensure the correct operation of the valves.

**Important:** According to the current local and national regulations, it is mandatory to add a switch (or other element to disconnect the system) to the external supply wiring so that a constant separation between poles is guaranteed. The system will restart automatically if the supply is eventually turned off.

## AIRZONE WIRED THERMOSTATS (AZDI6BLUEFACEC / AZDI6THINKC / AZDI6LITEC)

### Assembly

Airzone thermostats are mounted on the wall through a support. It is recommended not to locate it more than 40 meters away from the main control board. To fix it to the wall, follow these steps (Fig. 54):

- Separate the back part of the thermostat from the wall support and make all the connections.
- Fix the back part of the thermostat to the wall.
- Place the display on the support once it is fixed.
- Place the anti-theft rods for additional Support (optional).

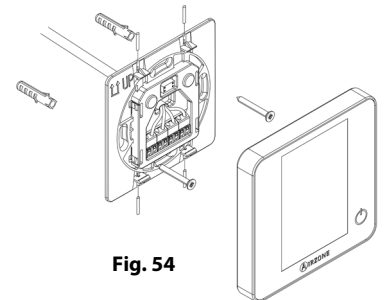

Fig. 54

### Connection

Airzone thermostats are connected to the zone module to be controlled. Attach the wires with the terminal screws following the color code (Fig. 55).

**Important:** Use the provided tool to press in the locking tabs (Fig. 56).

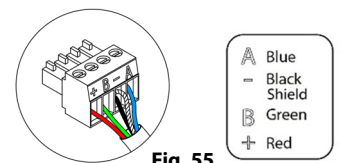

Fig. 55

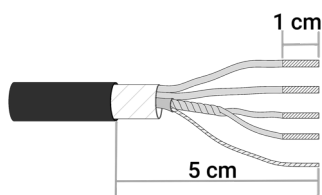
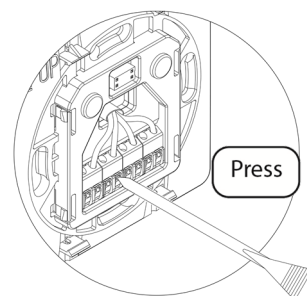

Fig. 56



## AIRZONE WIRELESS THERMOSTATS (AZDI6THINKR / AZDI6LITER)

### Assembly

Wireless thermostats are mounted on the wall through a support. It is recommended not to locate it more than 40 meters away from the main control board.

To fix it to the wall, follow these steps (Fig. 57):

- Separate the back part of the thermostat from the wall support and insert the CR2450 button battery.
- Fix the back part of the thermostat to the wall.
- Place the display on the support once it is fixed.
- Place the anti-theft rods for additional support.

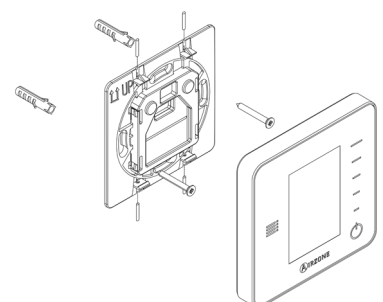



Fig. 57

### Changing batteries

When a Think thermostat is running out of battery, it displays this icon  on the screensaver (Fig. 58). In the case of wireless Lite thermostats, a warning message will be displayed on the Blueface. In order to know the zone of the Lite thermostat(s) running out of battery press on the warning icon (Fig. 59).

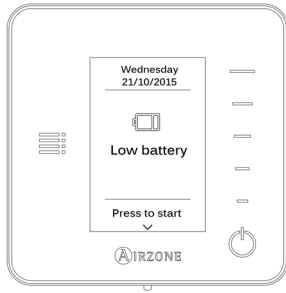

Fig. 58



Fig. 59

To replace the battery, separate the thermostat from its support and replace the battery (CR2450) (Fig. 60).

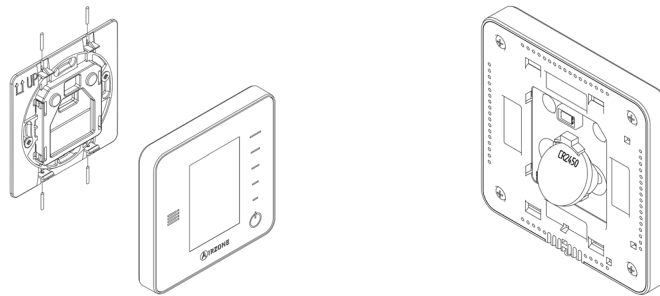

Fig. 60

**Important:** We recommend using of top-brand batteries. Using low-quality batteries may reduce the duration of use. Remember to deposit the old battery into an appropriate recycling point.

**Note:** Do not forget to remove the security system before taking away the thermostat from the wall.

### AIRZONE 0-10 V FANCOIL CONTROL GATEWAY (AZX6010VOLT SZ)

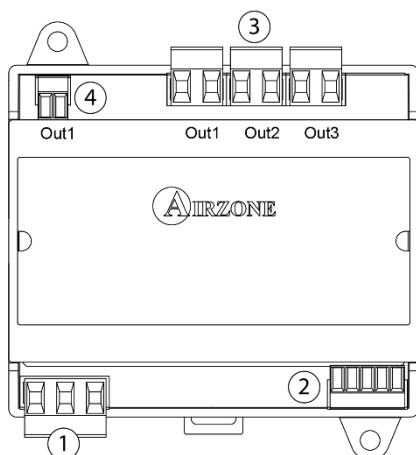

Fig. 61

Meaning	
①	Power supply
②	AC unit module
③	OUT 1   Cooling air demand
	OUT 2   Heating air demand
	OUT 3   Fan demand
④	Fan speed

### Assembly

The 0-10 V communication gateway is mounted on DIN rail (Fig. 62) or on wall (Fig. 63). This module is externally powered at 110/230 Vac. It should be placed and mounted in accordance with the current electrotechnical regulations.

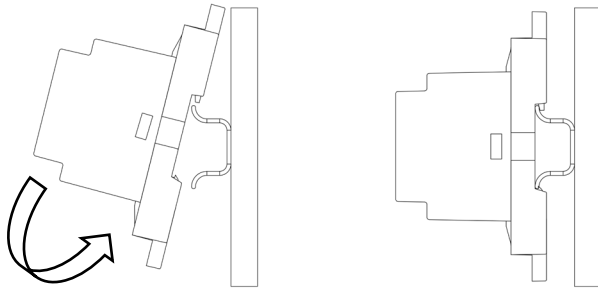

Fig. 62

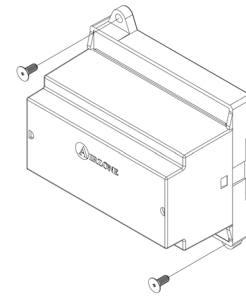

Fig. 63

**Note:** To remove the module on DIN rail, pull the tab down to release it.

### Connection

The 0-10 V gateway is connected to the AC unit bus of the main board (Fig. 64 and 65).

### Wiring diagram, 2-pipe installation

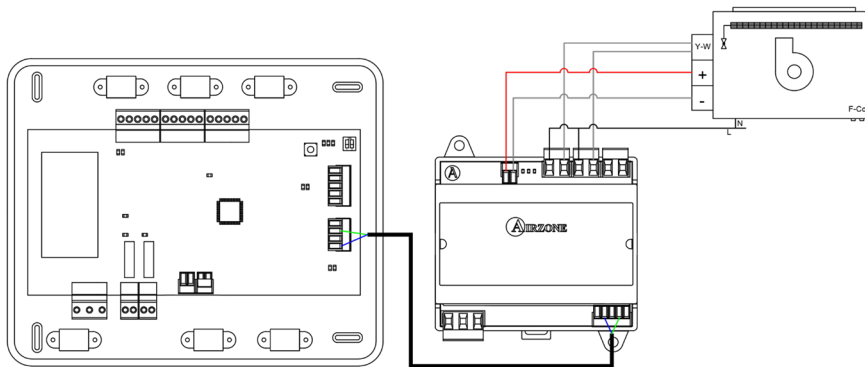

Fig. 64

### Wiring diagram, 4-pipe installation

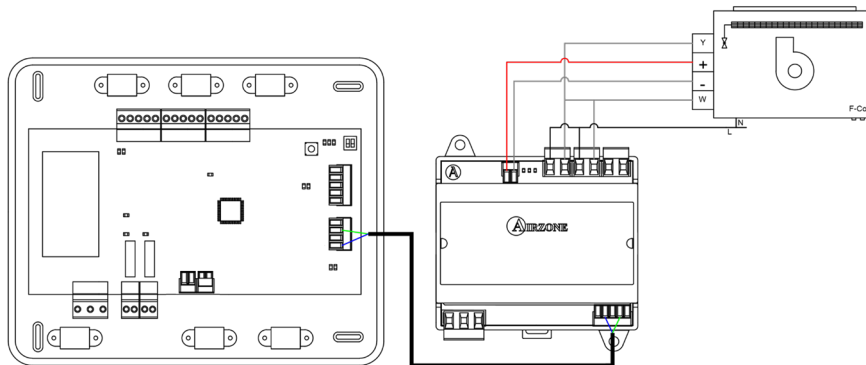

Fig. 65

Control relay specs:  $I_{max} = 10 \text{ A}$  at 110/230 Vac, voltage-free. Note that to control elements with a greater power, it is recommended to use contactors in accordance with the power required.

It has a 5-pin terminal to connect it to the AC unit bus of the main board <sup>②</sup>. Attach the wires with the terminal screws following the color code (Fig. 66). Use the shield only on the connector of the main control board.

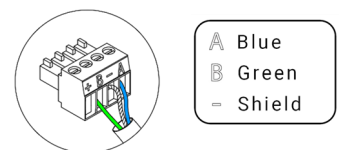

Fig. 66

It is connected to the module through a 3-pin terminal <sup>①</sup>. Attach the wires with the terminal screws following the color code (Fig. 67).

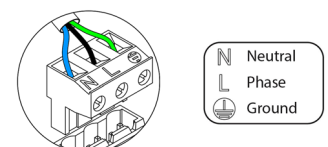
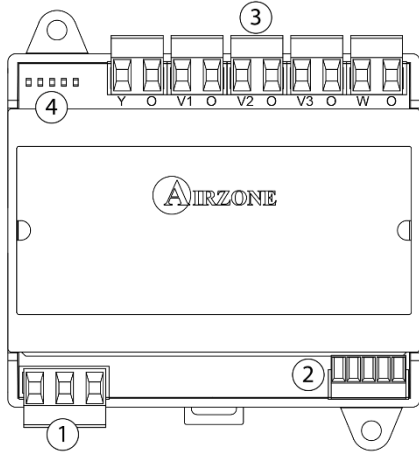

Fig. 67

**Important:** According to the current local and national regulations, it is mandatory to add a switch (or other element to disconnect the system) to the external supply wiring so that a constant separation between poles is guaranteed. The system will restart automatically if the supply is eventually turned off.

### AIRZONE CONTROL GATEWAY 3 SPEEDS FANCOIL (AZX6FANCOILZ)



No.	Description	
①	Power supply	
②	AC unit module	
③	Y-O	Cooling air demand
	V1-O	Speed 1
	V2-O	Speed 2
	V3-O	Speed 3
④	W-O	Heating air demand
	Status LEDs	

Fig. 68

### Assembly

Fan coil control gateway is mounted on DIN rail (Fig. 69) or on wall (Fig. 70). This module is externally powered at 110/230 Vac. It should be placed and mounted in accordance with the current electrotechnical regulations.

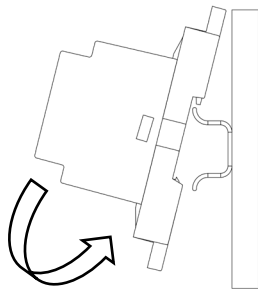

Fig. 69

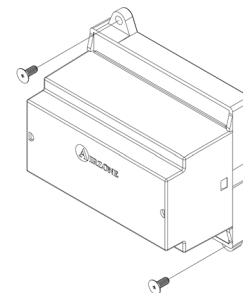
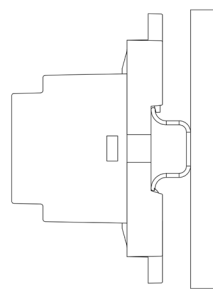

Fig. 70

**Note:** To remove the module on DIN rail, pull the tab down to release it.

### Connection

Fancoil control gateway is connected to the AC unit bus of the main board (Fig. 71 and 72).

### Wiring diagram, 2-pipe installation

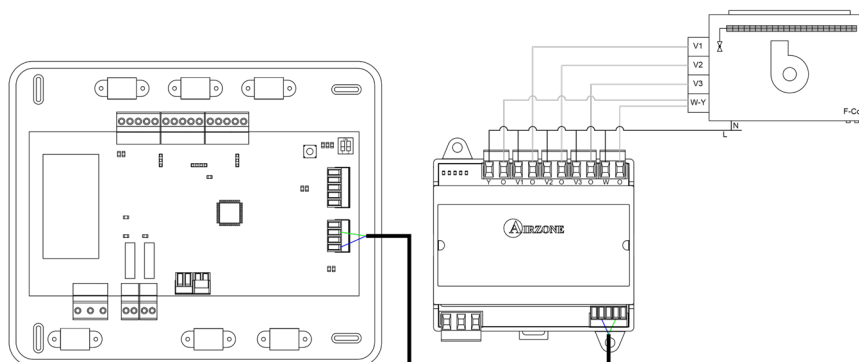
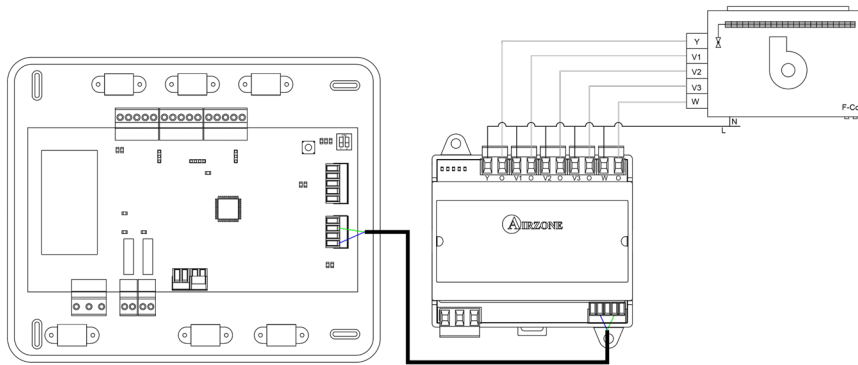

Fig. 71

## Wiring diagram, 4-pipe installation



**Fig. 72**

Control relay specs:  $I_{max} = 10 \text{ A}$  at 110/230 Vac, voltage-free. Note that to control elements with a greater power, it is recommended to use contactors in accordance with the power required.

It has a 4-pin terminal to connect it to the AC unit bus of the main board <sup>②</sup>. Attach the wires with the terminal screws following the color code (Fig. 73). Use the shield only on the connector of the main control board.

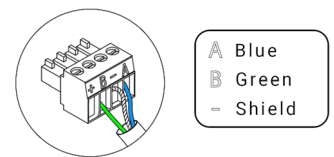

**Fig. 73**

It is connected to the module through a 3-pin terminal <sup>①</sup>. Attach the wires with the terminal screws following the color code (Fig. 74).

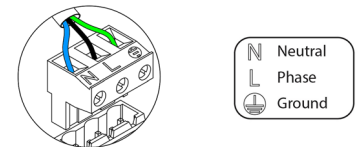

**Fig. 74**

**Important:** According to the current local and national regulations, it is mandatory to add a switch (or other element to disconnect the system) to the external supply wiring so that a constant separation between poles is guaranteed. The system will restart automatically if the supply is eventually turned off.

## AIRZONE CONTROL GATEWAY FOR ELECTROMECHANICAL UNITS (AZX6ELECTROMECH)

### Assembly

The electromechanical gateway is mounted on DIN rail (Fig. 75) or on wall (Fig. 76). This module is externally powered at 110/230 Vac. It should be placed and mounted in accordance with the current electrotechnical regulations.

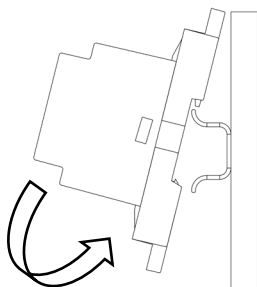

**Fig. 75**

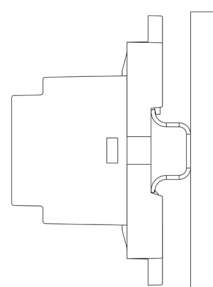

**Fig. 76**

**Note:** To remove the module on DIN rail, pull the tab down to release it.

## Connection

The control gateway for electromechanical units connects to the AC unit bus of the main board (Fig. 77).

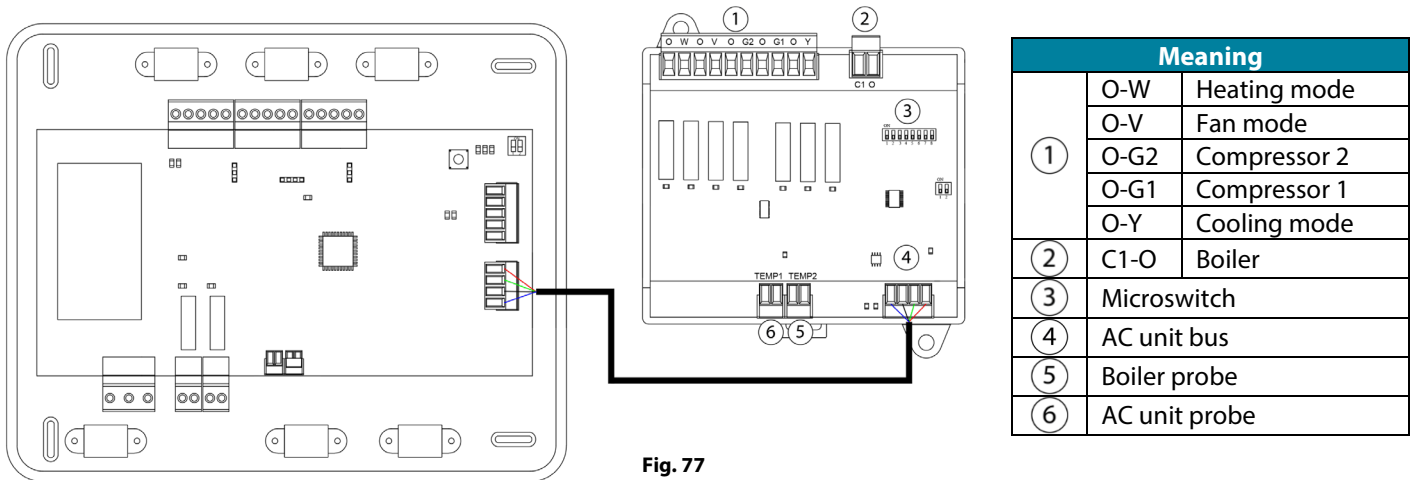

Fig. 77

Control relay specs: 24/48 Vac (voltage-free). Note that to control elements with a greater power, it is recommended to use contactors in accordance with the power required.

The operation logic of the microswitch is as follows:

Meaning		
1	Set-up time of the compressor	ON: 4 min OFF 10 seconds
2	Continuous ventilation	ON: Always ON (except for Stop mode) OFF: Only if there is demand
3	Units of 1 or 2 stages	ON: 2 stages OFF 1 stage

The operation logic of the relays is as follows:

Air conditioning	Demand	O-W	O-V	O-G2	O-G1	O-Y	C1-O
Stop	-	--	--	--	--	--	--
Ventilation	Yes	--	ON	--	--	--	--
	No	--	--	--	--	--	--
Cooling Air (1 stage)	Yes	--	ON	--	ON*	ON	--
	No	--	--	--	--	ON	--
Cooling Air (2 stages)	If return T > 28°C	ON	ON	ON	ON	ON	--
	If return T < 28°C	ON	ON	--	ON*	ON	--
	No	ON	--	--	--	ON	--
Heating air (1 stage)	Yes	ON	ON	ON	ON*	--	--
	No	ON	--	--	--	--	--
Heating air (2 stages)	If return T < 18°C	ON	ON	ON	ON	--	--
	If return T > 18°C	ON	ON	--	ON*	--	--
	No	ON	--	--	--	--	--
Radiant heating	Yes	ON	--	--	--	--	--
	No	ON	--	--	--	--	--
Combined heating	Diff. > Z°C	ON	ON	ON	ON	--	ON
	Diff. < Z°C	ON	--	--	--	--	ON
	No	ON	--	--	--	--	--

\*Note: Alternative activation of the compressor outputs (O-G1 – O-G2).



It has a 4-pin terminal to connect it to the AC unit bus of the main board ④. Attach the wires with the terminal screws following the color code (Fig. 78).

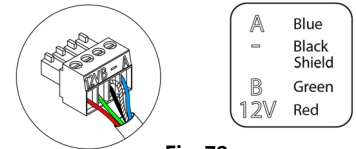
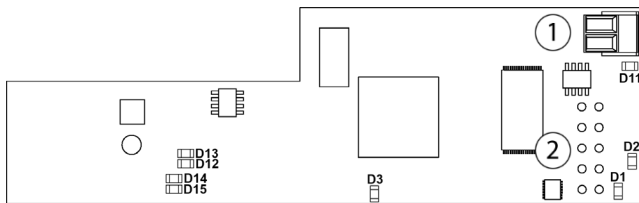

Fig. 78

## WEBSERVER AIRZONE CLOUD WI-FI DUAL 2.4-5G (AZX6WSC5GER)



N°	Description
①	Automation bus output
②	Automation bus input



All Airzone systems must be connected to internet to offer technical support.

It is only necessary to connect **one Webserver Cloud per installation** (control of up to 32 systems).

### Assembly

The Webserver is integrated into the automation bus of the Control board. It has a 5-pin terminal. Disconnect the terminal and fit the connector.

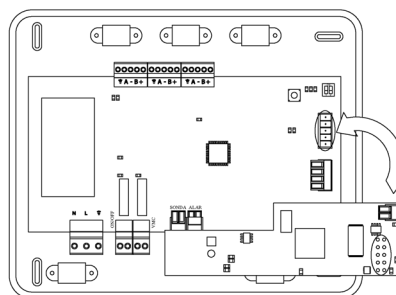

### Connection

To connect with other system's main boards, use the 2-pin terminal to connect the Webserver Cloud to the automation bus of the main board. Use the proper cable: shielded twisted pair 2 wired: 2x0.22 mm<sup>2</sup> (AWG 24 – 2 wired). Attach the wires with the terminal screws following the color code.

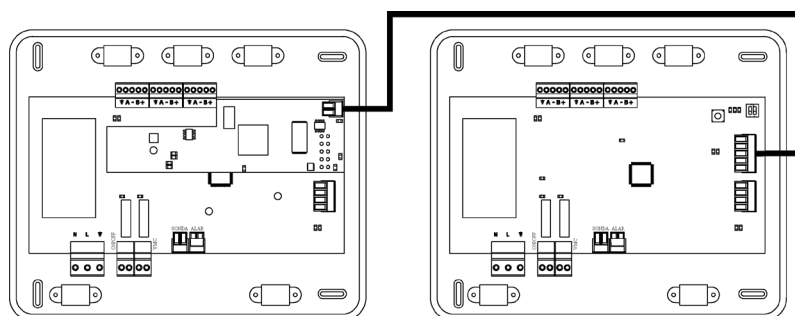
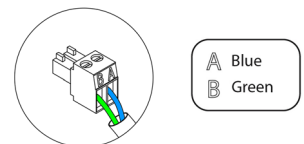

**Note:** For a proper operation of this module, all the control boards must be addressed (see section [Advanced Settings, System ID parameter](#)).

## Configuration

To configure it, follow the steps described in the Airzone Cloud Webserver installation manual, available at [myzone.airzone.es \(https://doc.airzone.es/producto/Gama\\_AZ6/Airzone/Comunes/Manuales/MI\\_AZCLOUD\\_MUL.pdf\)](https://doc.airzone.es/producto/Gama_AZ6/Airzone/Comunes/Manuales/MI_AZCLOUD_MUL.pdf)

### WEBSERVER HUB AIRZONE CLOUD DUAL (AZX6WSPHUB)

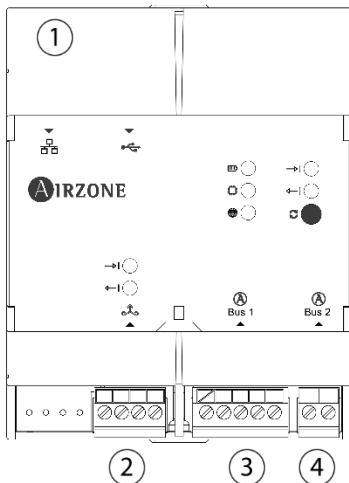

N°	Description
①	Ethernet
②	Modbus port
③	Airzone connection bus 1 – DM1
④	Airzone connection bus 2 – DM2

## Assembly

The Webserver HUB is mounted on DIN rail or on wall. It should be placed and mounted in accordance with the current electrotechnical regulations.

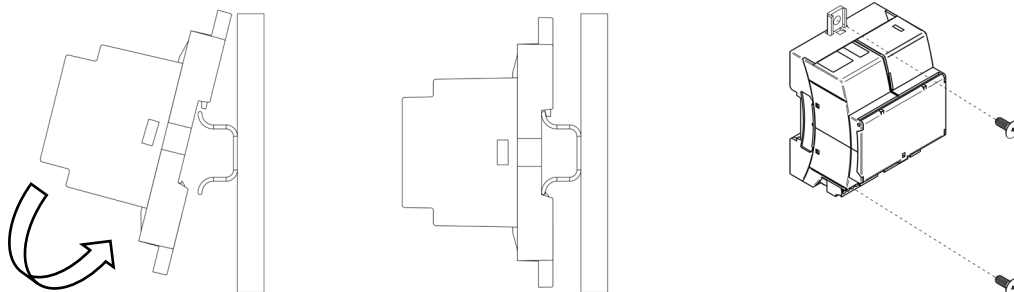

**Note:** To remove the module on DIN rail, pull the tab down to release it.

## Connection

To connect with the first system main board, use the 5-pin terminal to connect the Webserver Cloud to the automation bus of the main board in order to provide power supply to the Webserver. Use the proper cable: shielded twisted pair 4 wired: 2x0,22 mm<sup>2</sup> + 2x0.5 mm<sup>2</sup> (2 x AWG23 + 2 x AWG 20). Attach the wires with the terminal screws following the color code.

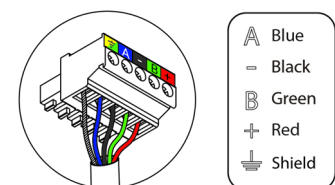

To connect with other system's main boards, use the 2-pin terminal to connect the Webserver Cloud to the automation bus of the other main boards. Use the proper cable: shielded twisted pair 2 wired: 2x0.22 mm<sup>2</sup> (AWG 23 – 2 wired). Attach the wires with the terminal screws following the color code.

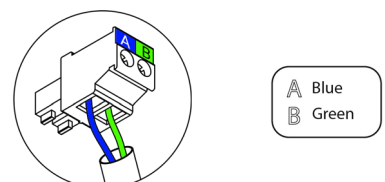

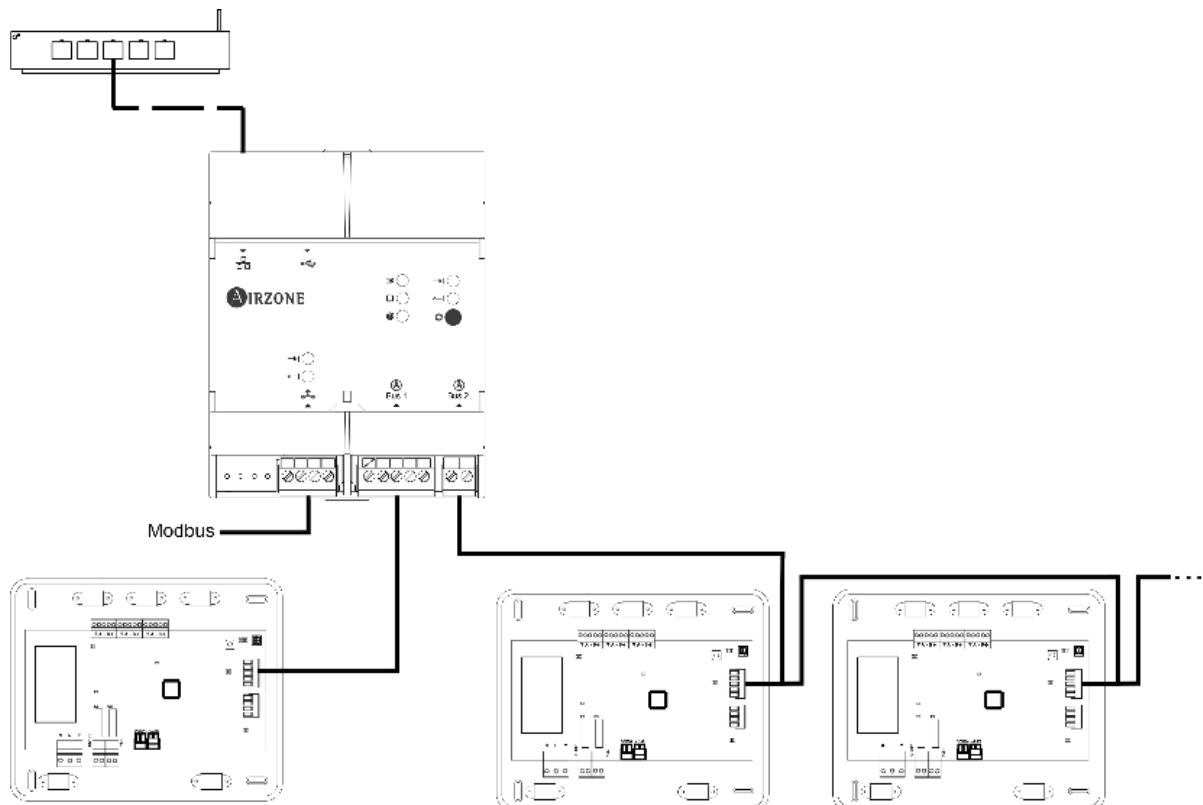

## Configuration

To configure it, follow the steps described in the Airzone Cloud Webserver installation manual, available at [myzone.airzone.es \(https://doc.airzone.es/producto/Gama\\_AZ6/Airzone/Comunes/Manuales/MI\\_AZCLOUD\\_MUL.pdf\)](https://doc.airzone.es/producto/Gama_AZ6/Airzone/Comunes/Manuales/MI_AZCLOUD_MUL.pdf)

## WEBSERVER HUB AIRZONE BACNET (AZX6WSPBAC)

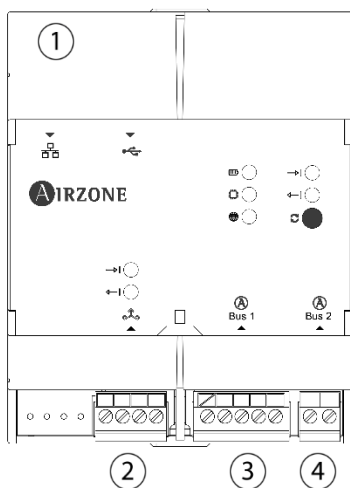

Nº	Description
①	Ethernet
②	Modbus port
③	Airzone connection bus 1 – DM1
④	Airzone connection bus 2 – DM2

## Assembly

The Webserver HUB BACnet is mounted on DIN rail or on wall. It should be placed and mounted in accordance with the current electrotechnical regulations.

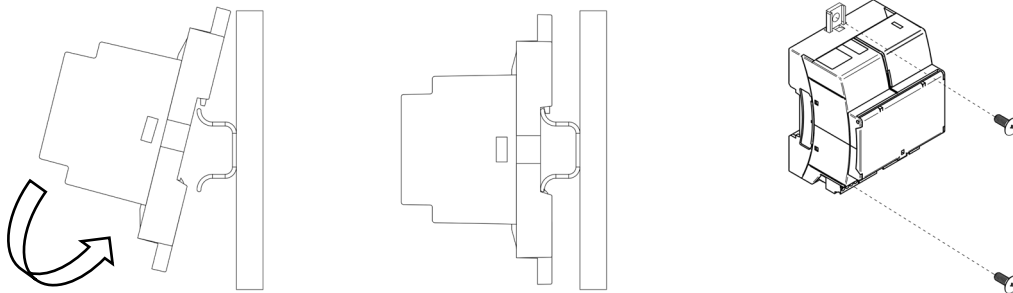

**Note:** To remove the module on DIN rail, pull the tab down to release it.

## Connection

To connect with the first system main board, use the 5-pin terminal of the DM1 domotic bus. Use the proper cable: shielded twisted pair 4 wired: 2x0,22 mm<sup>2</sup> + 2x0,5 mm<sup>2</sup> (2 x AWG23 + 2 x AWG 20). Attach the wires with the terminal screws following the color code.

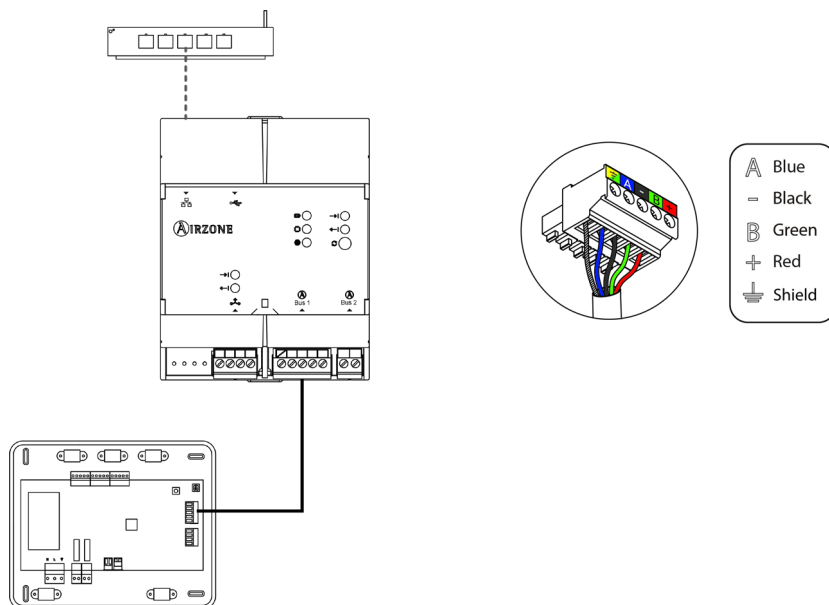

## Configuration

To configure it, follow the steps described in the Airzone Cloud Webserver installation manual, available at [myzone.airzone.es](http://myzone.airzone.es) ([http://doc.airzone.es/producto/Gama\\_AZ6/Airzone/Comunes/Manuales/MI\\_AZ6\\_BACNET\\_A4\\_EN.pdf](http://doc.airzone.es/producto/Gama_AZ6/Airzone/Comunes/Manuales/MI_AZ6_BACNET_A4_EN.pdf))

## WEBSERVER HUB AIRZONE-LUTRON (AZX6WSPLUT)

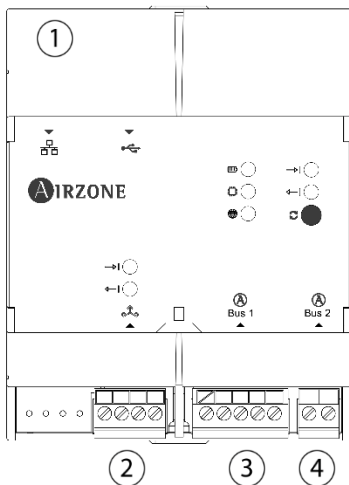

N°	Description
①	Ethernet
②	Modbus port
③	Airzone connection bus 1 – DM1
④	Airzone connection bus 2 – DM2

### Assembly

The Webserver HUB Lutron is mounted on DIN rail or on wall. It should be placed and mounted in accordance with the current electrotechnical regulations.

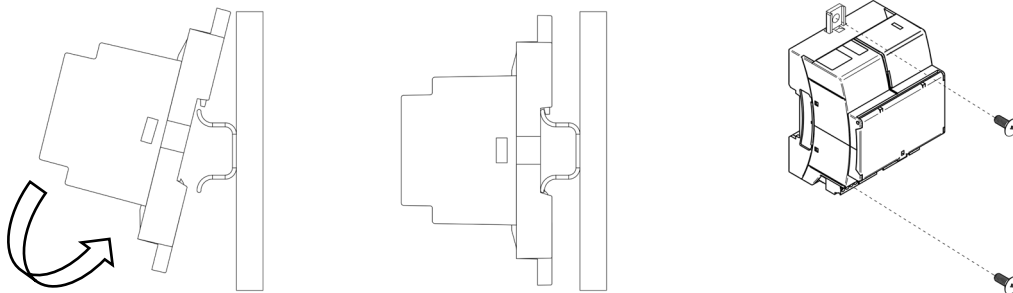

**Note:** To remove the module on DIN rail, pull the tab down to release it.

### Connection

To connect with the first system main board, use the 5-pin terminal to connect the Webserver Cloud to the automation bus of the main board in order to provide power supply to the Webserver. Use the proper cable: shielded twisted pair 4 wired:  $2 \times 0,22 \text{ mm}^2 + 2 \times 0,5 \text{ mm}^2$  (2 x AWG23 + 2 x AWG 20). Attach the wires with the terminal screws following the color code.

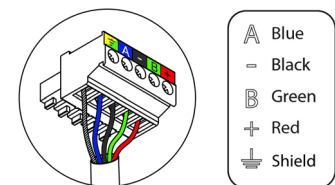

To connect with other system's main boards, use the 2-pin terminal to connect the Webserver HUB to the automation bus of the other main boards. Use the proper cable: shielded twisted pair 2 wired:  $2 \times 0,22 \text{ mm}^2$  (AWG 23 – 2 wired). Attach the wires with the terminal screws following the color code.

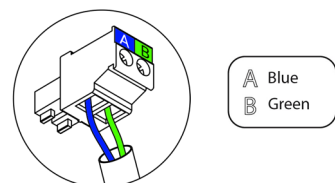

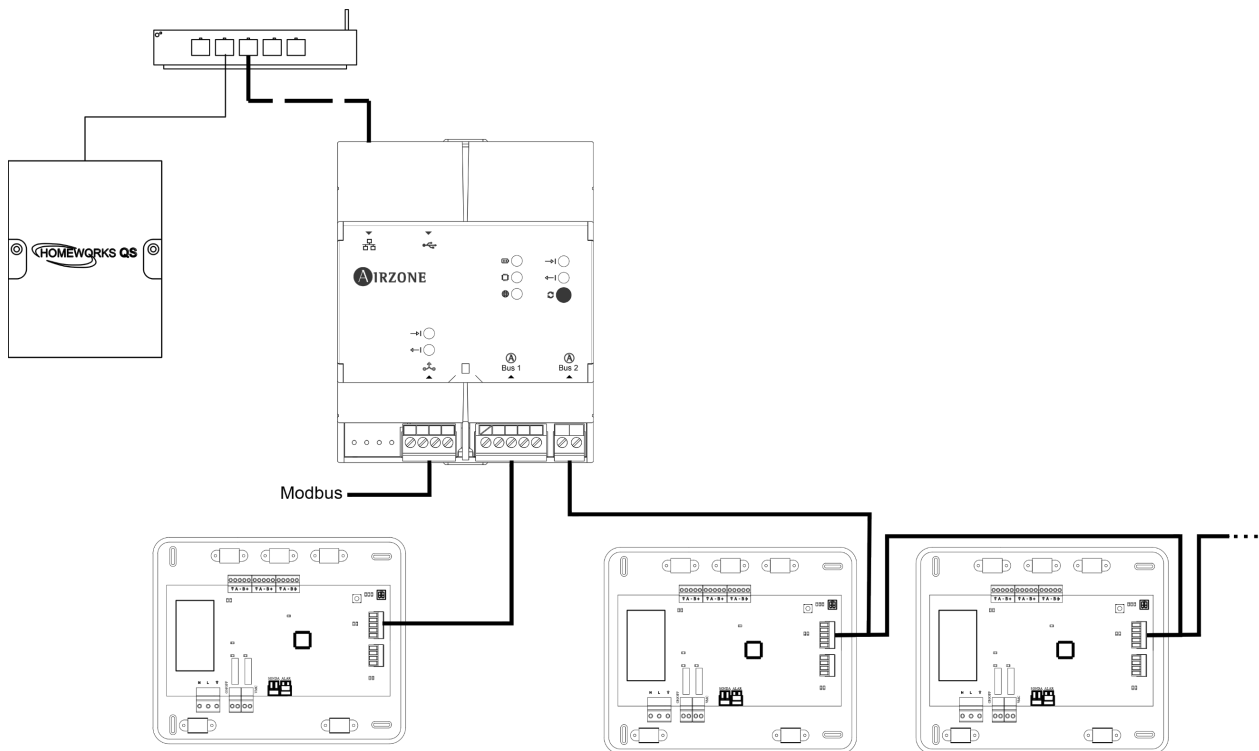

All Airzone systems must be connected to internet to offer technical support.

It is only necessary to connect **one Lutron integration gateway per installation** (control of up to 32 systems). All the system control boards must be correctly addressed.

## Configuration

To configure it, follow the steps described in the Airzone Cloud Webserver installation manual, available at [myzone.airzone.es](http://myzone.airzone.es) ([http://doc.airzone.es/producto/Gama\\_AZ6/Airzone/Comunes/Manuales/MI\\_AZ6\\_LUTRON\\_A4\\_EN.pdf](http://doc.airzone.es/producto/Gama_AZ6/Airzone/Comunes/Manuales/MI_AZ6_LUTRON_A4_EN.pdf))

## AIRZONE SUPERMASTER CONTROLLER AZX6CSMASTER [S/E] [B/G]

### Assembly

Supermaster controllers can be mounted on wall (AZX6CSMASTERS) (Fig. 93) or wall-embedded (AZX6CSMASTERE) (Fig. 94).

#### Wall mounting

- Separate the back part of the thermostat from the wall support.
- Fix the support directly to the wall or using a patten.
- Put the back part of the controller on the support (once it is fixed) passing the cable through the hole. Make sure that the back part is fixed by the tabs. Make all the connections.
- Place the display on its back part.

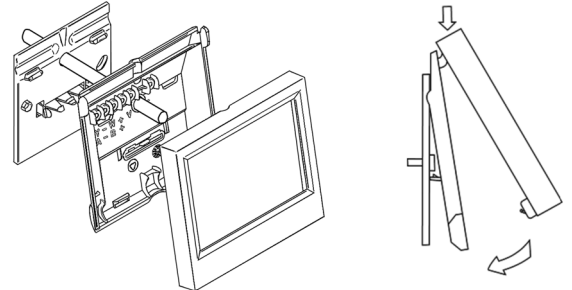

Fig. 93

#### Embedded mounting

Embedded Supermaster thermostats are supplied in 100x100 junction boxes. Compatible junction boxes:

- Solera 362 (100x100 mm)
- Jangar 2174 (100x100 mm)
- IDE CT110 (100x100 mm)
- Fematel Ct35 (100x100 mm)

For a perfect mounting, follow these steps:

- Remove the sub-frame of the display from the rest of the assembly and make the connections.
- Use the washers and screws to secure the display into the patters.
- Place the sub-frame again. Make sure it is fixed properly.

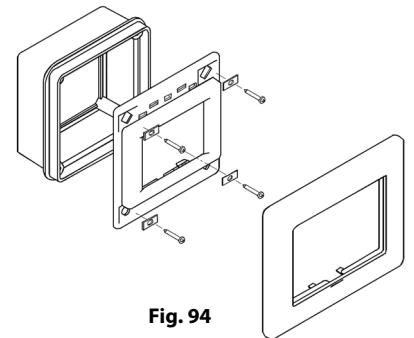

Fig. 94

### Connection

The Supermaster controller is connected to the domotic bus of the main control board.

For wall Supermaster, use the tabs located on their back part, Attach the wires with the tab screws following the color code (Fig. 95).

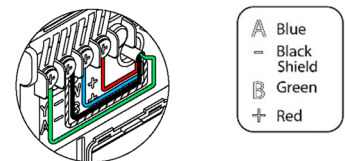

Fig. 95

Wall-embedded Supermaster have a 5-pin terminal located on their back part. Attach the wires with the terminal screws following the color code (Fig. 96).

**Note:** To configure it, follow the steps described in the user's manual, available at [myzone.airzone.es/products](http://myzone.airzone.es/products)

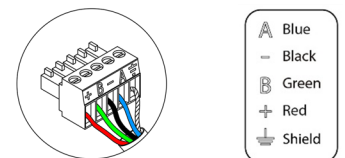

Fig. 96

([http://doc.airzone.es/producto/Gama\\_AZ6/Airzone/Comunes/Manuales/MU\\_AZ6\\_SMAESTRO\\_A4\\_MUL.pdf](http://doc.airzone.es/producto/Gama_AZ6/Airzone/Comunes/Manuales/MU_AZ6_SMAESTRO_A4_MUL.pdf))

**Note:** For a proper operation of this module, all the main control boards must be addressed (see section Advanced settings).

## AIRZONE HYDRONIC PRODUCTION CONTROL BOARD (AZX6CCPGAWI)

### Assembly

The production control board is supplied to be screwed to the wall. It should be placed and mounted in accordance with the current electrotechnical regulations. For the mounting of the main control board, follow the following steps:

- Locate the control board close to the unit to be controlled.
- Unscrew the cover securing the back part to the wall.
- Make all the connections and screw the cover again.

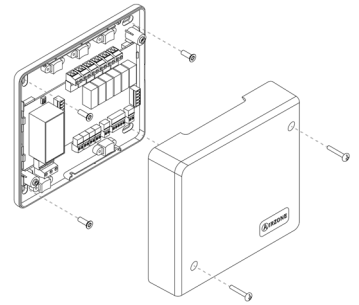

### Connection

Production control board is connected to the AC unit bus of the main board.

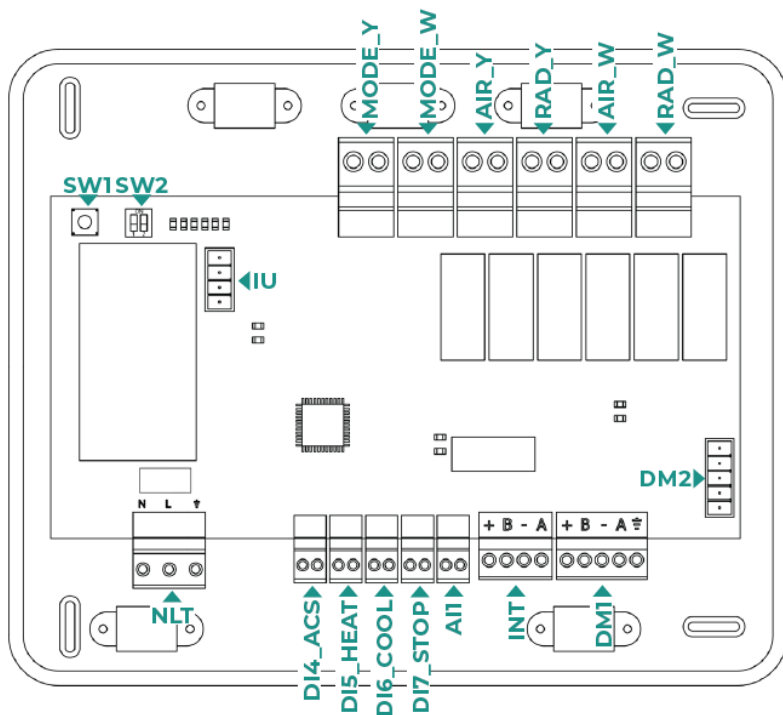

N°	Description
NLT	Power supply
DI4_ACS	Deactivates the air conditioning through AC unit during DHW production
DI5_HEAT	Sets the heating semiforced mode
DI6_COOL	Sets the cooling semiforced mode
DI7_STOP	Imposes the Stop mode in the system
AI1	Reserved for internal use
INT	Integration bus output
DM1/DM2	Domotic bus outputs
IU	Air to water domotic bus output
MODE_Y	Cooling mode
MODE_W	Heating mode
AIR_Y	Cooling air demand
RAD_Y	Cooling radiant demand
AIR_W	Heating air demand
RAD_W	Heating radiant demand
SW1	Systems search
SW2	Configuration

### Power supply connector

This connector powers the main control board and all the elements connected to it. Externally powered at 110/230 Vac. It is connected through a 3-pin terminal. Attach the wires with the terminal screws following the color code. For added security, secure the wires using the turret.

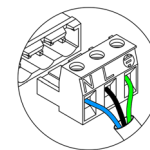

N Neutro | Neutral | Neutro  
 L Fase | Phase | Fase  
 T Tierra | Ground | Terra

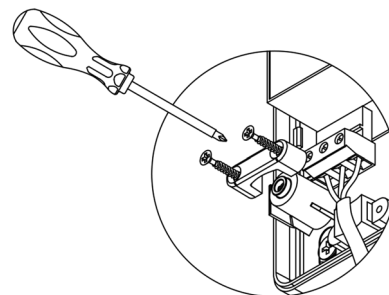
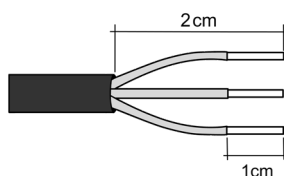

**Important:** According to the current local and national regulations, it is mandatory to add a switch (or other element to disconnect the system) to the external supply wiring so that a constant separation between poles is guaranteed. The system



will restart automatically if the supply is eventually turned off. **Use an independent circuit from the controlled system for the power supply.**

**Remember:** Once all the connections are made, make sure you replace the cover properly.

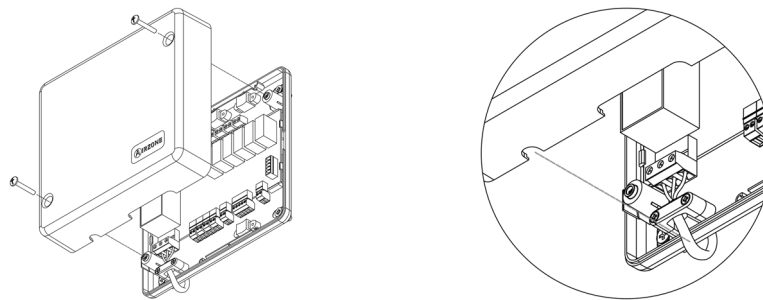

### Digital inputs

The production control board has 4 digital inputs to externally control the Airzone systems. These input are configured as normally open. It is recommended to use a shielded cable to connect it.

- DI4\_ACS: This input activates the DHW mode: all the Acuazone/Innobus Pro32 systems working on Air heat will stop and the message DHW will be displayed by the zone thermostats. This feature is recommended for Aerothermal installations when the Aerothermal unit starts producing DHW.
- DI5\_HEAT: This input activates the semi-forced heating mode in all the system of the installation. These are the modes available to select: Stop, Heating and Ventilation.
- DI6\_COOL: This input activates the semi-forced cooling mode in all the system of the installation. These are the modes available to select: Stop, Dry, Cooling and Ventilation.
- DI7\_STOP: This input activates the Stop mode in all the system of the installation.
- AI1: Analog input reserved for internal use.

### DM1 bus connector

The DM1 domotic bus allows the connection of system main control boards and the Webserver HUB Airzone Cloud Dual (AZX6WSPHUB).

It has two 5-pin terminals for the DM1 bus connection. This system can only be connected by bus. Remember that it is necessary to provide power supply through this port by connecting the 5-pins. Attach the wires with the terminal screws following the color code.

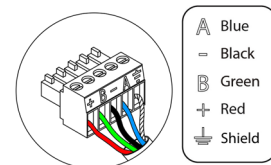

**Note:** For a proper operation of the main control board, all the main control board must be addressed (up to 32 systems).

### DM2 domotic bus connector

The DM2 domotic bus allows the connection of control peripherals in order to manage all the systems connected to the production control board. These are the elements that can be connected:

- Webserver Airzone Cloud Wi-Fi Dual 2.4-5G (AZX6WSC5GER)
- Webserver Airzone Cloud Ethernet/WiFi (AZX6WEBSCLLOUD [C/R]).
- Webserver Airzone Cloud Carril Din Ethernet/WiFi (AZX6WSCLOUDDIN [C/R]).

It has a 5-pin terminal for the DM2 bus connection. This system can only be connected by bus. Attach the wires with the terminal screws following the color code.

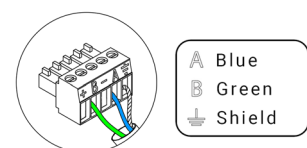

**Note:** Do not provide power supply in DM2 or IU ports. For externally powered elements at 110/230 Vac, it is only needed to connect "A" and "B" from the automation bus.

When connecting the Webserver Cloud (AZX6WSC5GER / AZX6WEBSCLLOUD [C/R]), remove the fixing post from the Webserver and put the connector in DM2.

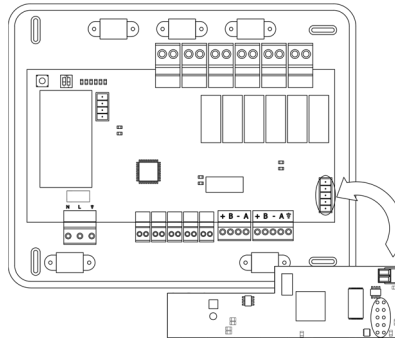

### UI bus connector for Aerothermal gateway

The UI bus allows you to connect multiple gateways of for air-to-water equipment installed. These are the elements that can be connected:

- Airzone aerothermal gateway (AZX6GAW xxx).

In order to connect these gateways, disconnect the terminal of the UI bus and fit in the connector and the fixing post of the gateway.

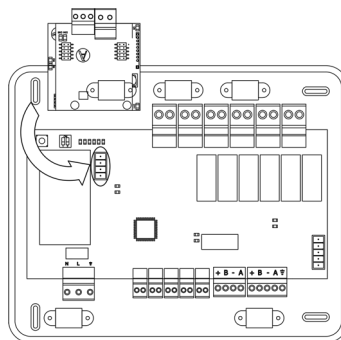

### Control relays

This device has 6 relays for controlling the installation. The characteristics of the control relays are  $I_{max}$  of 10 A at 110/230 Vac (voltage-free. Note that to control elements with a greater power, it is recommended to use contactors in accordance with the power required.

**Important:** Remember to connect the neutral connector directly from the circuit to the element to be controlled.

Depending on the type of installation, the control relays will follow a different logic:

#### Aerothermal

Mode	Demand	Control Relays					
		MODE_Y	MODE_W	AIR_Y	RAD_Y	AIR_W	RAD_W
Stop	Off	--	--	--	--	--	--
Cooling mode	Air	ON	--	ON	--	--	--
	Radiant	ON	--	--	ON	--	--
	Off	--	--	--	--	--	--
Heating mode	Air	--	ON	--	--	ON	--
	Radiant	--	ON	--	--	--	ON
	Off	--	--	--	--	--	--
Dry	On	--	--	--	--	--	--
	Off	--	--	--	--	--	--
Ventilation	On	--	--	--	--	--	--
	Off	--	--	--	--	--	--

2 pipes / 3/ 4 pipes

Mode	Demand	Control Relays					
		MODE_Y	MODE_W	AIR_Y	RAD_Y	AIR_W	RAD_W
Stop	Off	--	--	--	--	--	--
Cooling mode	Air	ON	--	ON	--	--	--
	Radiant	ON	--	--	ON	--	--
	Off	ON	--	--	--	--	--
Heating mode	Air	--	ON	--	--	ON	--
	Radiant	--	ON	--	--	--	ON
	Off	--	ON	--	--	--	--
Heating mode	On	ON	--	--	--	--	--
	Off						
Ventilation	On	--	--	--	--	--	--
	Off						

RadianT

Mode	Demand	Control Relays					
		MODE_Y	MODE_W	AIR_Y	RAD_Y	AIR_W	RAD_W
Stop	Off	--	--	--	--	--	--
Cooling mode	Radiant	ON	--	--	ON	--	--
	Off	--	--	--	--	--	--
Heating mode	Radiant	--	ON	--	--	--	ON
	Off	--	--	--	--	--	--
Dew warning active	On	ON	--	ON	--	--	--
	Off	ON	--	ON	--	--	--

**For Acuazone and Innobus Pro 32 systems versions v.4.4.1 or higher:** In any configuration of the Acuazone central operating logic, zones with air flow stage configured as (Direct Expansion) DX will not generate air demand in the production control board. Remember that in both zoned or mixed configurations, when the air flow stage of a zoned area is modified, the same configuration will apply to the rest of the zones in the group.

**Important:** The following combinations will not generate air demand in the production control board:

- Communication gateway (AZX6QADAPTxxx / AZX6QADAPT3xxx / AZX6GTC xxx / AZX6ELECTROMECH) in Flexa 3.0, Innobus Pro6, Acuazone and Innobus Pro32 (v.4.4.0 or lower) main control boards.
- Gateway modules (AZDI6MCIFR [C/R] / AZDI6MCxxx [C/R] / AZDI6ZMOxxx [C/R]) in Acuazone e Innobus Pro32 (v.4.4.0 or lower) systems (when configured as a zoning system or mixed system).

**Important:** To guarantee the optimization of the production temperature of the aerothermal units, these device combinations do not generate demand to the production control board:

- Zoning module for Electrical Heating Element (AZDI6MZSRE [C/R]) in Acuazone and Innobus Pro32 systems regardless of the Main control board configuration.

### SW1

Once all the main control boards have been addressed, you must save the configuration of the installation in the production control board. To do that, press SW1. If you make any changes in the installation, remember to save the new configuration.

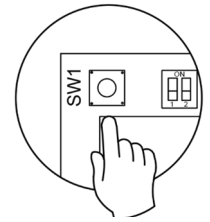

### SW2

The microswitch SW2 sets the type of installation to control by the central production control. The operation logic of the microswitch is as follows:

Meaning			
Aerothermal	2 pipes	3/4 pipes	RadianT*

\*Only for Airzone RadianT365 system (AZRA6).

**Important:** The control relays operation logic can be configured from SW2 or from the Production Parameters section on the advanced configuration menu. Configuration from the menu always has priority over SW2.

## AIRZONE PRODUCTION CONTROL BOARD (AZX6CCP)

### Assembly

The production control board is supplied to be screwed to the wall (Fig. 104). It should be placed and mounted in accordance with the current electrotechnical regulations. For the mounting of the main control board, follow the following steps:

- Locate the control board close to the unit to be controlled.
- Unscrew the cover securing the back part to the wall.
- Make all the connections and screw the cover again.

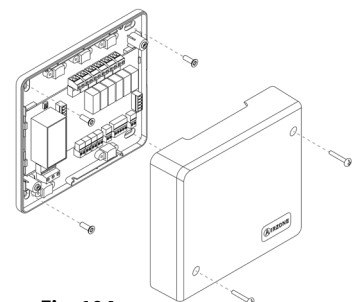

Fig. 104

### Connection

Production control board is connected to the AC unit bus of the main board (Fig. 105).

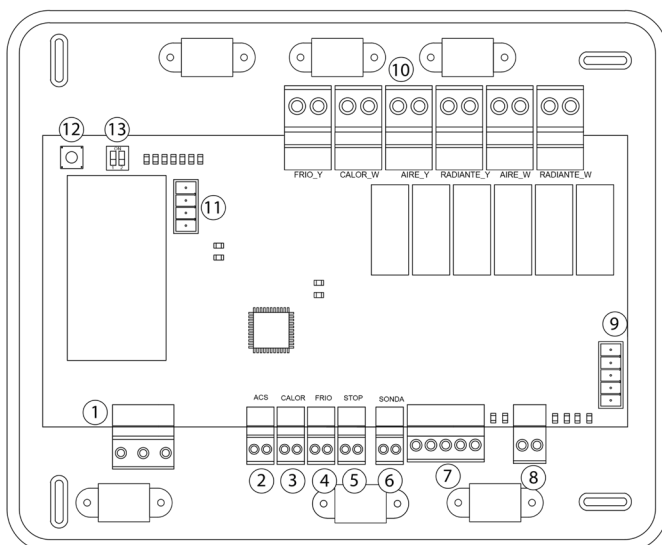

Fig. 105

No.	Description		
1	Power supply		
2	Digital inputs		
...			
6			
7	External domotic bus 2		
8	Internal domotic bus		
9	External domotic bus 1		
10	Control relays	FRIO_Y	Cooling mode
		CALOR_W	Heating mode
		AIRE_Y	Cooling air demand
		RADIANTE_Y	Cooling radiant demand
		AIRE_W	Heating air demand
		RADIANTE_W	Radiant heating demand
11	Aerothermal gateway bus		
12	SW1		
13	SW2		

### Power supply connector

This connector powers the main control board and all the elements connected to it. Externally powered at 110/110/230 Vac. It is connected through a 3-pin terminal. Attach the wires with the terminal screws following the color code (Fig. 106). For added security, secure the wires using the turret (Fig. 107).

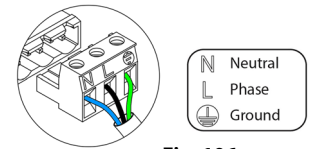

Fig. 106

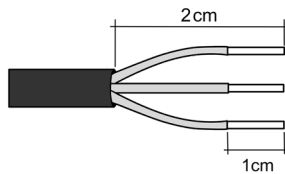
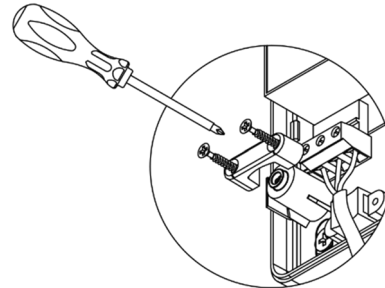

Fig. 107



**Important:** According to the current local and national regulations, it is mandatory to add a switch (or other element to disconnect the system) to the external supply wiring so that a constant separation between poles is guaranteed. The system will restart automatically if the supply is eventually turned off.

**Remember:** Once all the connections are made, make sure you replace the cover properly (Fig. 108).

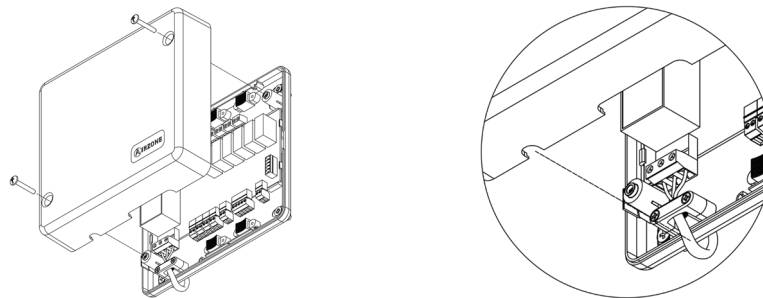

Fig. 108

### Digital inputs

The production control board has 4 digital inputs to externally control the Airzone systems. These inputs are configured as normally open. It is recommended to use a shielded cable to connect it.

- ACS: This input activates the DHW mode: all the systems working on Air heat will stop and the message DHW will be displayed by the zone thermostats. This feature is recommended for Aerothermal installations when the Aerothermal unit starts producing DHW.
- CALOR: This input activates the semi-forced heating mode in all the system of the installation. These are the modes available to select: Stop, Heating and Ventilation.
- FRIO: This input activates the semi-forced cooling mode in all the system of the installation. These are the modes available to select: Stop, Cooling, Dry and Ventilation.
- STOP: This input activates the Stop mode in all the system of the installation.

The main control board has an analogical input to connect a temperature probe for boiler protection.

### External domotic bus connectors

The external domotic bus allows you to interconnect multiple systems in order to control them through the Airzone control peripherals control or to integrate them into a superior control network. These are the gateways that can be connected:

- Webserver Airzone Ethernet Cloud/WiFi (AZX6WEBSCLLOUD [C/R]) (External domotic bus 1)
- Webserver Airzone Cloud DIN Ethernet/Wifi (AZX6WSCLOUDDIN [C/R]).

It has two 5-pin terminals for the domotic bus connection. This system can only be connected by bus. Attach the wires with the terminal screws following the color code (Fig. 109).

**Note:** For elements externally powered at 110/230 Vac, for the communications, it is only necessary to connect the poles "A", "B" and "Shield" of the domotic bus.

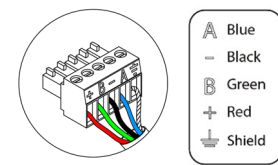

Fig. 109

In order to connect the Webserver Cloud (AZX6WEBSCLLOUD [C/R]), remove the fixing post from the Webserver and fit the connector into the external domotic bus 1 (Fig. 110).

### Indoor domotic bus connectors

The indoor domotic bus allows you to interconnect the production control board with the main control board. It has a 2-pin terminal for the domotic bus connection. This system can only be connected by bus. Attach the wires with the terminal screws following the color code (Fig. 111).

**Note:** For a proper operation of this main control board, all main control boards must be addressed (up to 32 zones) (see section Advanced settings).

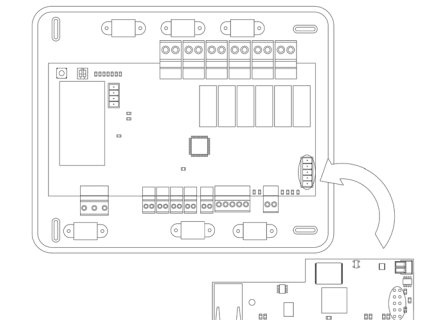

Fig. 110

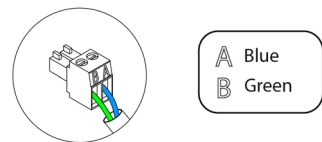

Fig. 111

### Aerothermal gateway bus connector

The AC unit bus allows you to connect multiple gateways of production control for air-to-water equipment installed. These are the gateways that can be connected:

- Daikin aerothermal gateway (AZX6ACUACP [DAI/DA2]).

In order to connect these gateways, disconnect the terminal of the AC unit bus and fit in the connector and the fixing post of the gateway (Fig. 112).

### Control relays

This device has 6 relays for controlling the installation. The characteristics of the control relays are  $I_{max}$ : 10 A at 110/230 Vac (tension-free). Note that to control elements with a greater power, it is recommended to use contactors in accordance with the power required.

**Important:** Remember to connect the neutral connector directly from the circuit to the element to be controlled.

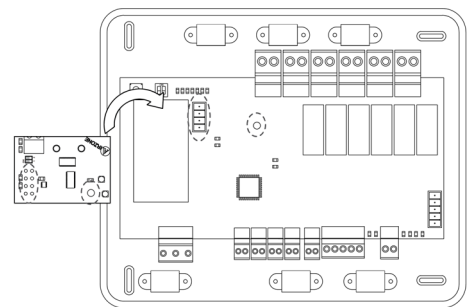

Fig. 112

Depending on the type of installation, the control relays will follow a different logic:

#### Aerothermal

Mode	Demand	Control Relays					
		FRIO_Y	CALORB_W	AIRE_Y	RADIANTE_Y	AIRE_W	RADIANTE_W
Stop	Off	--	--	--	--	--	--
Cooling mode	Air	ON	--	ON	--	--	--
	Radiant	ON	--	--	ON	--	--
	Off	--	--	--	--	--	--
Heating mode	Air	--	ON	--	--	ON	--
	Radiant	--	ON	--	--	--	ON
	Off	--	--	--	--	--	--
Dry	On	--	--	--	--	--	--
	Off	--	--	--	--	--	--
Ventilation	On	--	--	--	--	--	--
	Off	--	--	--	--	--	--

#### 2 pipes / 4 pipes

Mode	Demand	Control Relays					
		FRIO_Y	CALORB_W	AIRE_Y	RADIANTE_Y	AIRE_W	RADIANTE_W
Stop	Off	--	--	--	--	--	--
Cooling mode	Air	ON	--	ON	--	--	--
	Radiant	ON	--	--	ON	--	--
	Off	ON	--	--	--	--	--
Heating mode	Air	--	ON	--	--	ON	--
	Radiant	--	ON	--	--	--	ON
	Off	--	ON	--	--	--	--
Heating mode	On	ON	--	--	--	--	--
	Off	ON	--	--	--	--	--
Ventilation	On	--	--	--	--	--	--
	Off	--	--	--	--	--	--

**For system versions v.4.4.1 or higher:** In any configuration of the Acuazone central operating logic, zones with air flow stage configured as (Direct Expansion) DX will not generate air demand in the production control board. Remember that in both zoned or mixed configurations, when the air flow stage of a zoned area is modified, the same configuration will apply to the rest of the zones in the group.

**For system versions v.4.4.0 or lower:** The following combinations will not generate air demand in the production control board:

- Communication gateway (AZX6QADAPTxxx / AZX6QADAPT3xxx / AZX6GTC xxx / AZX6ELECTROME) in Flexa 3.0, Innobus Pro6, Acuazone and Innobus Pro32 main control boards.
- Gateway modules (AZDI6MCIFR [C/R] / AZDI6MCxxx [C/R] / AZDI6ZMOxxx [C/R]) in Acuazone e Innobus Pro32 systems (when configured as a zoning system or mixed system).

**Important:** To guarantee the optimization of the production temperature of the aerothermal units, these device combinations do not generate radiant demand to the production control board:

- Zoning module for Electrical Heating Element (AZDI6MZSRE [C/R]) in Acuazone and Innobus Pro32 systems regardless of the Main Control Board configuration.

### SW1

Once all the main control boards have been addressed, you must save the configuration of the installation in the production control board. To do that, press SW1 (Fig. 113). Remember to save your configuration after making any changes. To reset the production control board, press SW2 for 10 seconds.

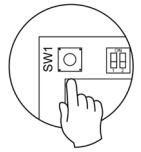

Fig. 113

### SW2

The microswitch SW2 configures the type of installation to be controlled by the production control board. The operation logic of the microswitch is as follows:

Meaning			
1 2	1 2	1 2	1 2
Aerothermal	2 pipes	3/4 pipes	RadianT

## KNX INTEGRATION GATEWAY (AZX6KNXGTWAY)

### Assembly

KNX integration gateway is mounted on DIN rail (Fig. 114). This module is powered through the domotic bus of the main control board and the KNX bus of the installation. It should be placed and mounted in accordance with the current electrotechnical regulations.

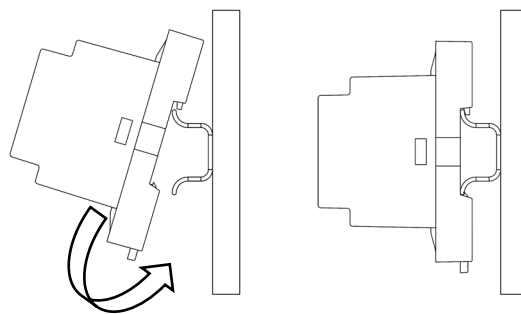

Fig. 114

**Note:** To remove the module, pull the tab down to release it.

### Connection

KNX gateway connects to the AC unit bus of the main board (Fig. 115).

No.	Description
①	Programming button
②	KNX Bus
③	Airzone Bus connection

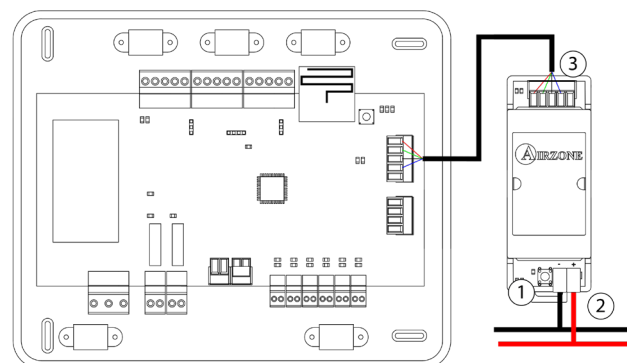

Fig. 115

It has a 5-pin terminal to connect it to the domotic bus of the main board ③. Attach the wires with the terminal screws following the color code (Fig. 116).

**Note:** To configure it, follow the steps described in the KNX installation manual (available at [myzone.airzone.es](http://myzone.airzone.es)).

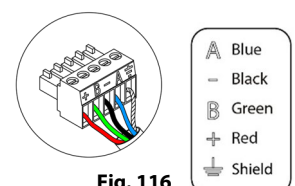

Fig. 116

([http://doc.airzone.es/producto/Gama\\_AZ6/Airzone/Comunes/Manuales/MI\\_AZX6KNXGTWAY\\_A4\\_EN.pdf](http://doc.airzone.es/producto/Gama_AZ6/Airzone/Comunes/Manuales/MI_AZX6KNXGTWAY_A4_EN.pdf))



## ASSEMBLY AND CONNECTION EVALUATION

Check the following aspects:

- The state of the LEDs of the main control board and the rest of control elements. Check the self-diagnose section of the data sheet of the elements.
- All thermostats are powered.

## SECONDARY ZONES SETTINGS

**IMPORTANT:** Can only be configured as secondary zones the zones controlled by a **wired zone module**.

To set secondary zones, follow these instructions:

- Perform the setup according to the next section.
- Disconnect the thermostat from the secondary module. After a few seconds, this module will be available on the menu of associated outputs.
- Once all secondary modules are configured, configure all modules or main modules and associate the secondary modes required.

**Note:** It is recommended the use of a Blueface thermostat for configuring subordinated zones.

## INITIAL SETUP

**Important:** Before making the initial setup of the system, firstly configure the subordinate zones, see section *Secondary Zones Settings*.

Once the system is installed and all the elements are correctly connected, it is time to power the system.

Follow the steps described in the following sections to configure all thermostats.

**Reset the system:** To reset the whole system, press and hold on SW1 (on the main control board) until the LED 19 stops blinking (Fig. 121).

**IMPORTANT:** To associate wireless thermostats, you must open previously the wireless association module. To do that, press on SW1. The LED D19 will remain solid red (Fig. 121). Once open, you have 15 minutes to make the association. If that period of time expires, start the process over again. Remember not to open more than one module at the same time, it may alter the process.

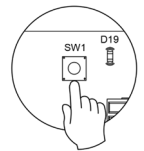

**Fig. 121**

You can also open the channel association radio through the Blueface (see section *system settings*).

## AIRZONE BLUEFACE AND AIRZONE THINK SETUP

**Important:** Once you start the process, it cannot be interrupted. You will be able to modify the desired parameters later.

### 1 Language/Country

Select your language and country. These are the available languages: Spanish, English, French, Italian, German and Portuguese.

To associate a wireless Think, press Airzone to start seeking and then confirm the Wireless association.

#### Setting wireless device

- Open the radio channel. To do that, press on SW1. The LED D19 will remain solid red. Once open, you have 15 minutes to make the association. If that period of time expires, start the process over again. Remember not to open more than one module at the same time, it may alter the process. You can also open the channel association radio through the Blueface and Think (see section System Settings)

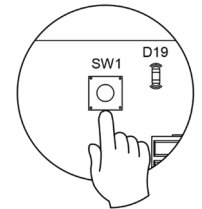

Fig. 122

**IMPORTANT:** not to open more than one radio channel at the same time, it may alter the process.

- Start the radio channel search, to do so, press Airzone to start the search.

The controller will display the different wireless zone modules found, with the signal level of each one of them. Select the wanted module and press "Check", the selected module will tone to be identified. Verify the range is correct (30% minimum) and confirm.

**IMPORTANT:** Before selecting the zone module which will be associated with the thermostat, check that this module is the desired one. If this module is not the correct one, use the control bar to select another module and check again.

**IMPORTANT:** The thermostat will display first the wireless zone modules which are closer to it. Remember to configure this thermostat near the wireless control module to associate for greater comfort.

### 2 Zone address

Select the zone associated to the thermostat. All the zones have a corresponding control output (output for motorized elements or control relay for radiant elements). For example, the zone 1 will control the control relay output O1 of the Control Module of Radiant Elements (AZDI6OUTPUT8).

### 3 Associated outputs

If necessary, the system allows the association more than one zone module to a zone. It is possible to control several control outputs from one single thermostat. Use the arrow keys to select the zone and press "associate" or "release" to make the configuration.

**Important:** You must select the zone/s that you want to configure as secondary outputs before pressing "Confirm".

### 4 Thermostat settings (only available in thermostats Blueface and wireless Think)

Select the operation of the thermostat:

- Master: Controls all the parameters of the installation.
- Zone: Controls all the parameters of the zone.

### 5 Control stages (only for installation with AZDI6OUTPUT8 modules)

Select the stages to be controlled in heating and cooling mode: Air, Radiant or Combined. On selecting the air stage, the user can set the type of production available in the zone (direct expansion or water unit).

### 6 Manufacturer ID (only available in installations with AZDI6MCIFRC modules)

Select the control protocol you want to use in the AC unit to be controlled.

Check the compatible IR gateway modules at:

[http://doc.airzone.es/producto/Gama\\_AZ6/Airzone/Distribuido/Fichas\\_tecnicas/Compatibilidades/UC\\_AZDI6MCIFR\\_MUL.pdf](http://doc.airzone.es/producto/Gama_AZ6/Airzone/Distribuido/Fichas_tecnicas/Compatibilidades/UC_AZDI6MCIFR_MUL.pdf)

**7 Master address** (only available for zone thermostats in installations configured as four-pipe, only if a Blueface thermostat has been previously configured as master)

Select the master thermostat address with which the thermostat is associated. Thus, this master thermostat will impose the operating mode to the thermostat.

**8 Other settings**

Press to finish the initial setup process, or access the advanced settings (system address, control stages, etc.) to change any other settings. Activate the basic function if required (see *Advanced Settings, Zone settings*).

**Blueface**

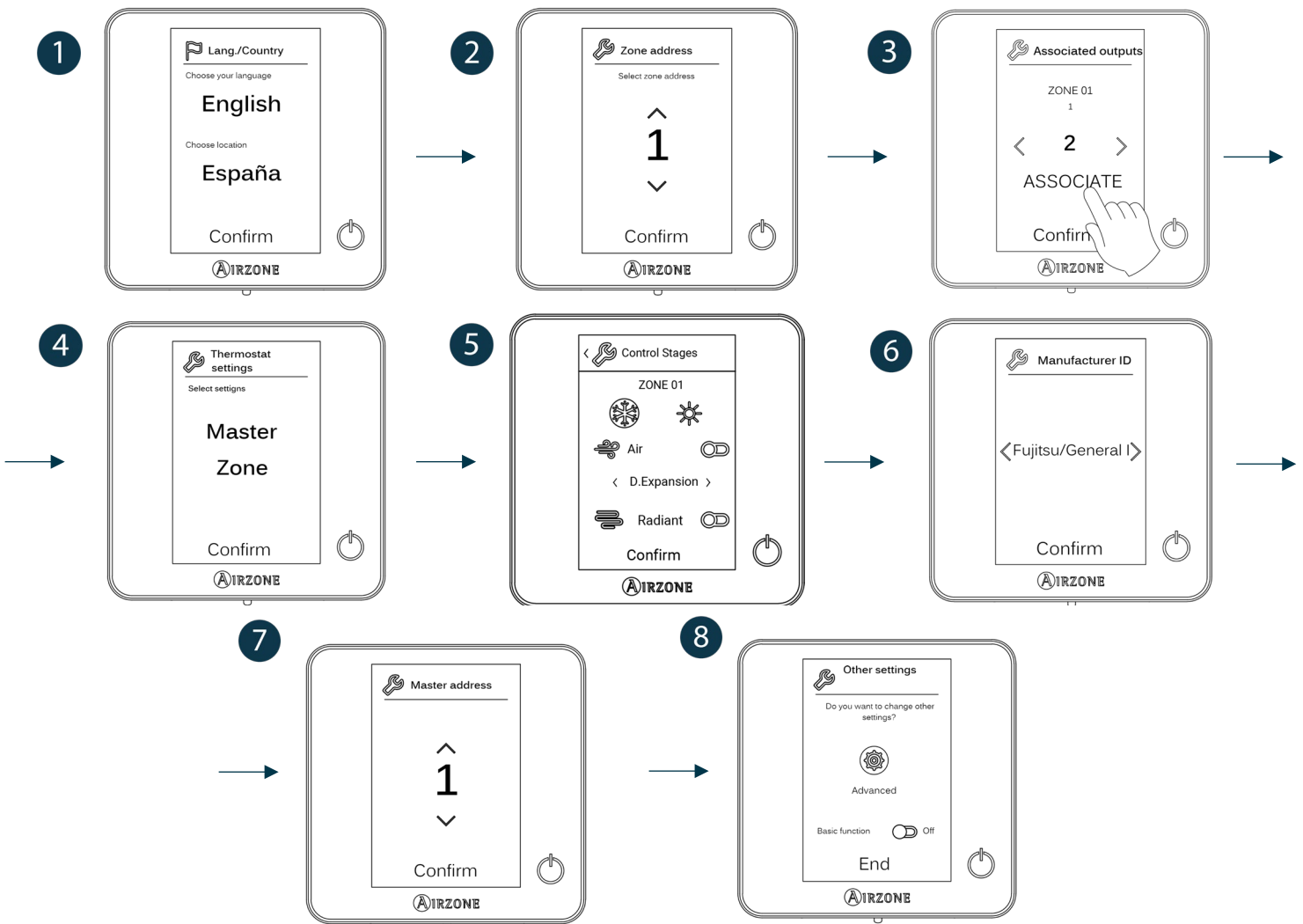

## Think

**Important:** In Think thermostats, use **AIRZONE** to confirm and **☰** to return to the previous screen or menu.

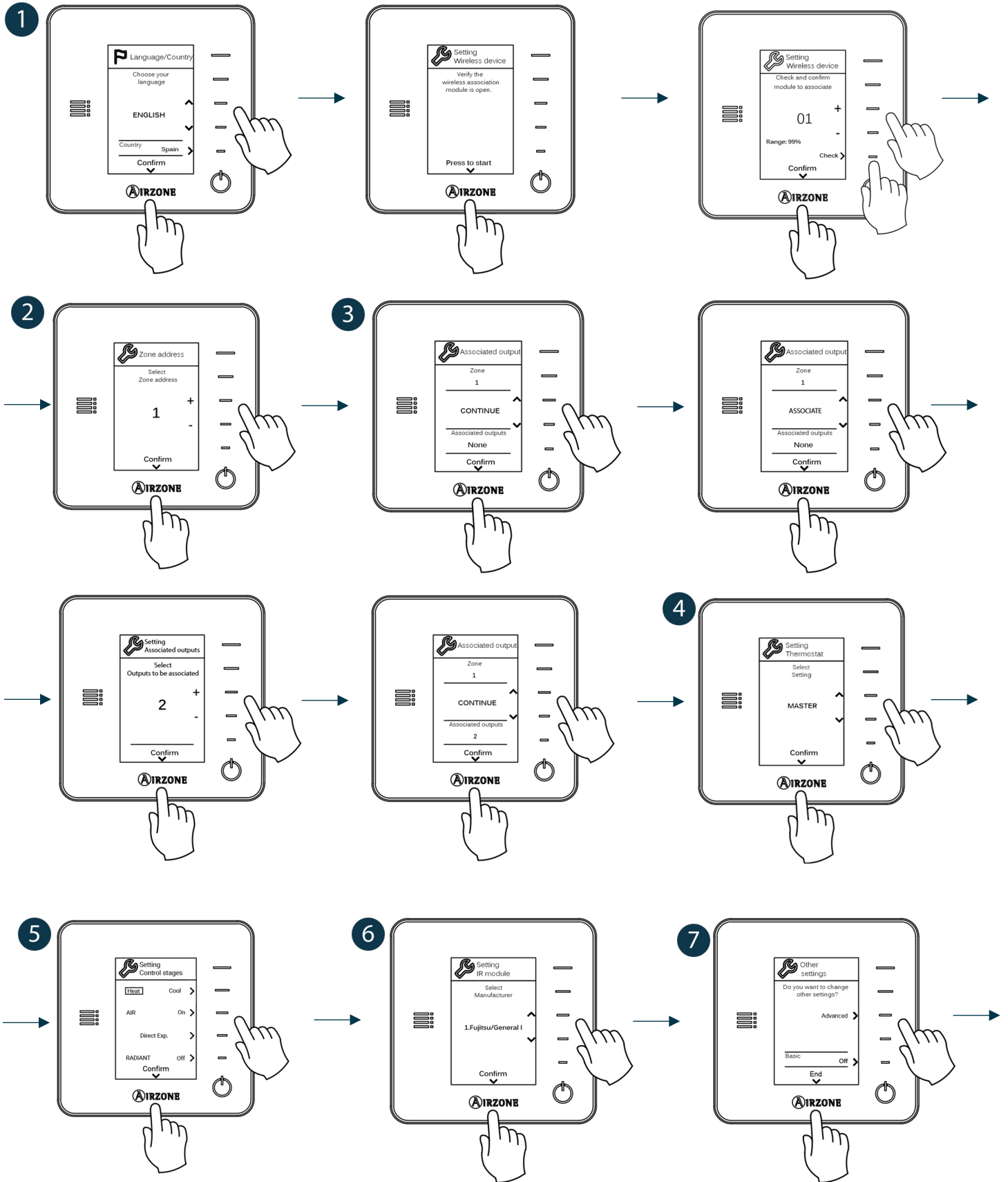

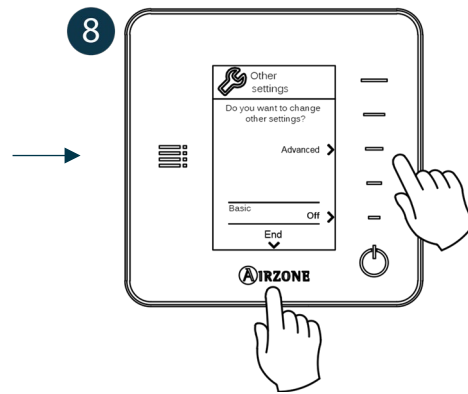













## AIRZONE LITE THERMOSTATS CONFIGURATION

To configure a Lite thermostat, follow these steps:

### Wired Lite thermostat

- Perform all the appropriate connections.
- Connect the thermostat.
- Press the LED  to confirm the association.
- The number of the zone which associates with the thermostat is the lowest free available number.
- If the association is correct, the LED  will blink green 5 times.

### Wireless Lite thermostat

- Open the wireless association channel of the main board, wait a few seconds so the control module, which will be associated to the thermostat, opens its wireless association channel (the wireless opening LED must be solid red).
- Insert the battery to supply the thermostat.
- Press the LED  to begin the wireless search. The LED  will blink in green.  
**IMPORTANT:** The thermostat will display first the wireless control modules which are closer to it. Remember to configure this thermostat near the wireless control module to associate for greater comfort.
- The module which will be associated to the Lite thermostat will begin to make a “beep” for its identification. The LEDs  will show the signal level of this module:
  - o  Low signal range level (It is not recommended to perform the association).
  - o  Medium signal range level.
  - o  Good signal range level
  - o  Excellent signal range level.
- Press the LED  to confirm the association, otherwise use  to select another module.
- The number of the zone which associates with the thermostat is the lowest free available number.
- If the association is correct, the LED  will flash green 5 times. If it flashes red twice, it means the thermostat is out of range.

**REMEMBER:** It is necessary to set the Master ID parameter of the Lite Thermostat for its proper functioning (see section *Advanced Settings – Zone Settings*).

Configure other functionalities of the LITE thermostat from the advanced configuration menu of a Blueface thermostat (see section *Advanced settings, Zone settings*) or Webserver Cloud (See Webserver Cloud installation manual).

**IMPORTANT:** For changing the zone address, access the parameter Zone Address, inside the advanced settings menu from a Blueface thermostat (see section *Advanced settings, Zone settings*).

## Reset Lite Thermostat

To reset to factory values of any Lite thermostat, turn up the microswitch 8 and place the thermostat on the base again. Press on , the LED will flash green twice when the reset process is completed.

To re-associate it, lower the microswitch 8, place the thermostat on its base and follow the steps described in *Initial Settings, Lite Controller*.

## INITIAL CONFIGURATION EVALUATION

Check the following aspects:

- AC unit-system communication: Choose any mode (except for STOP mode) and switch on the zone to generate demand.
- Opening-closing of the dampers, ON/OFF of individual AC units and control outputs: Turn on the system and generate demand in all the zones. Then, switch off and on each zone to verify the element to be controlled operates properly.

**Remember:** For security reasons, the last zones takes 4 minutes to close.







**Important:** After the setup or in case of power outage, the system takes a few minutes to measure precisely the temperature and the relative humidity.

**Important:** When the system stops generating demand, the motorized elements of the activated zones will remain open and the unit will remain on, setting a set-point temperature of 30°C for cooling mode and 16°C for heating mode.

## USER AND ZONE SETTINGS

### USER SETTINGS – AIRZONE BLUEFACE THERMOSTAT

From this setting the user can control and change several features. Press on  to see all the direct access list:

-  **Language/Country.** Select your language and country.
-  **Brightness.** Select the brightness intensity and activate/deactivate the brightness on the screensaver. Select the brightness intensity and activate/deactivate the brightness on the screensaver.
-  **Screensaver.** Determine what information to display on the screensaver. Depending on the configuration of your system, you can choose among this list:
  - Zone state: Displays information about the zone state and settings
  - Weather forecast: Only available with Airzone Cloud (AZX6WBSCLOUD [C/R] and AZX6WSCLOUDDIN [C/R]).
  - AC unit consumption: Only available for some configurations.
  - If you deactivate the information feature, only the time and zone state will be displayed.
-  **Date and time.** Press on the clock to set the time, the format type (12 or 24 hours) and whether or not you want the automatic change of time. Press on the calendar to set the date.
-  **Clean screen.** Activate this feature to lock the screen for some seconds to clean the screen.
-  **Information.** Displays information about:
  - Zone: Firmware, zone, association, actuator o communications status.
  - System: Firmware, configuration and information about the controllers.
  - Devices: Displays what elements are connected to the system.
  - Webserver (*Only for system 1 Master thermostat*): Webserver status and settings, association to router.
  - Warning: It warns you if any error occurs.

## ZONE SETTINGS – AIRZONE BLUEFACE THERMOSTATS

Press on  to access this menu. You will see these settings:

 **Sleep mode.** The Sleep mode works as an eco-timer that switches off the zone.

These are the values you can select:

- **OFF.** The timing is off.
- **30.** The zone turns off after 30 minutes.
- **60.** After the 30 minutes, the temperature increases or decreases in one degree and then after 30 more minutes, the zone turns off.
- **90.** After the 30 minutes, the temperature increases or decreases in one degree. 30 minutes later, the process is repeated (+/- 1 degree). After 90 minutes, the zone will switch off.

 **Anti-freezing.** This feature prevents the room temperature from lowering below 12°C, although your zone is off. (Not available in Stop mode).

Depending on the type of installation and configuration of your system, you will find other features:

 **Grille angle\*.** This feature allows defining the angle of the slats of the Airzone smart grilles in cooling or heating mode. It is set at 90° by default.

 **Adjust slats\*.** This feature allows defining the inclination type of the horizontal and vertical slats on the systems where this function is available.

 **Control stages\*.** In case of controlling air and radiant elements in your zone, this feature allows you to select which one to use in heating mode. It is set to Combined by default.

*\*Note: For security reasons the zone is turned off when you change any of these parameters.*

 **Lite settings.** Selects the set-point temperature of the zone where the Airzone Lite is located. Moreover, from the Status LED feature, you can configure your Wired Lite thermostat to switch off after a few seconds (while the status of the zone is shown).

*Note: To access this setting, you must access to navigation by zones, to the area controlled by a thermostat Lite.*

## USER SETTINGS - AIRZONE THINK THERMOSTAT

**Remember:** In Think thermostats, use to confirm and to return to the previous screen or menu.

Press on to access this menu. You will see these settings:

**Sleep mode.** The Sleep mode works as an eco-timer that switches off the zone. These are the values you can select:

- **OFF.** The timing is off.
- **30.** The zone turns off after 30 minutes.
- **60.** After the 30 minutes, the temperature increases or decreases in one degree and then after 30 more minutes, the zone turns off.
- **90.** After the 30 minutes, After 30 minutes, the temperature increases or decreases in one degree. 30 minutes later, the process is repeated (+/- 1 degree). After 90 minutes, the zone will switch off.

**Zone navigation.** Access any zone and turn it on/off, check the information of the zone or change the set point.

Depending on the type of installation you have, you may be able to select the fan speed of the AC unit:



## ADVANCED SETTINGS

To access the advanced configuration menu of the thermostat and Blueface Think follow the following steps:

### Blueface

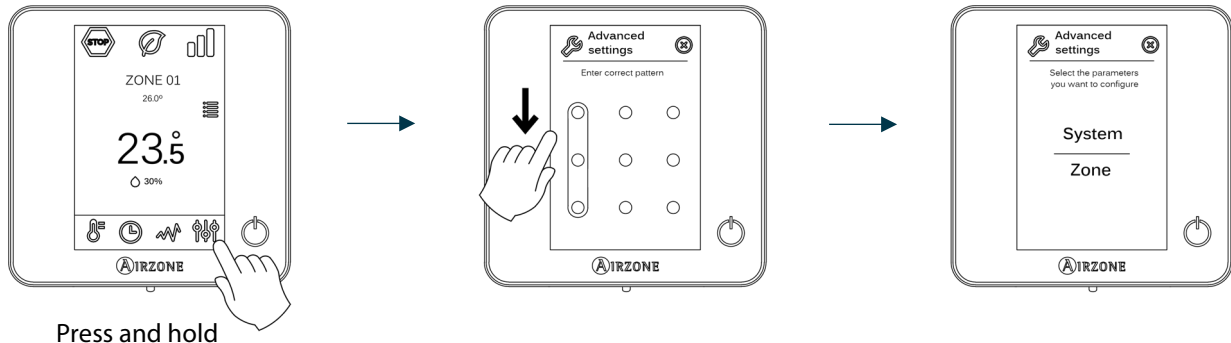

### Think

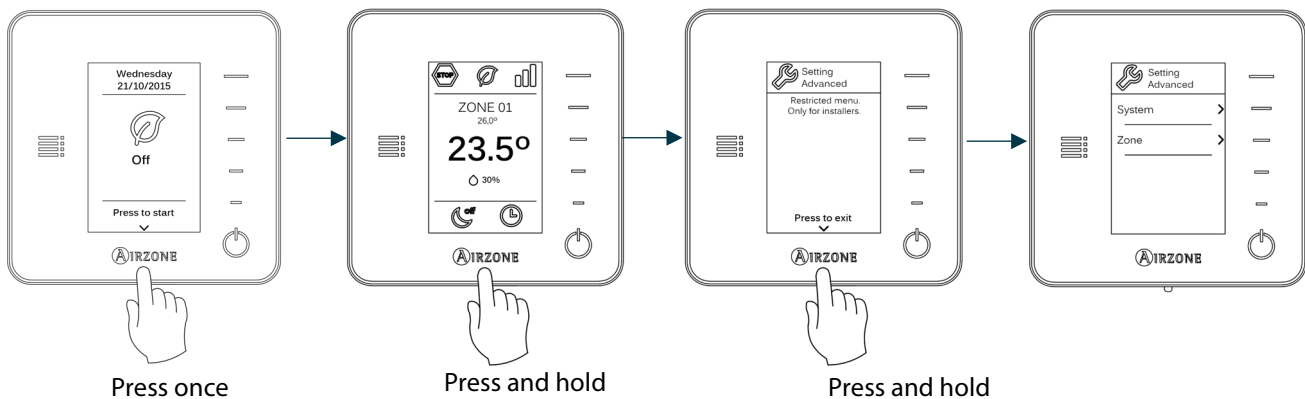

From this menu you can control both the zone parameters and the system parameters.



## SYSTEM SETTINGS

### Blueface

- **System address** (*Not available on systems with BACnet*). Defines the number of the system within your installation. The value 1 is shown by default. The system will display the available values (max = 99).

If the system has address 1 and there is a production control board (AZX6CCP) in the installation, it is possible to activate Supermaster feature which imposes the operating mode of system 1 to the rest of the systems connected to the AZX6CCP:

Operating modes: System 1	Available modes: Rest

- **Temperature range.** Selects the highest temperature in heating mode (19-30 °C) and the lowest temperature in cooling mode (18-26 °C). It is also possible to disable some of the modes. The highest temperature by default is 30°C. The lowest temperature by default is 18°C.
- **Combined stage** (*Only available for installations with AZDI6OUTPUT8 modules*). Enables activating and deactivating the combined stage of the "Control Stages" parameter in the user's Zone Settings Menu.
- **Hysteresis Configuration.** Defines the temperature differential between room temperature and set-point temperature required to start applying the RadianT algorithm (if the control stage is set as radiant) or to apply the Combined Algorithm (if the control stage is set as combined). In installations with radiators, set this value to 0°C. It is set to 0°C by default.
- **Standby Mode.** Allows motorized elements to be kept open in cooling/heating mode when the set-point temperature has been reached and the AC unit remains switched on in low consumption mode. However, if it is deactivated, the AC unit will turn off and the motorized elements will close.
- **Standby Hysteresis.** (Only available when Standby mode is activated.) Allows you to set the activation temperature for Standby mode (by default it is activated at 16 °C in heating mode and at 30 °C in cooling mode). The initial setting for hysteresis is 0 °C.
- **Type of opening** (*only available in installations with AZDI6MZZON [C/R] modules*). Use this to activate/deactivate the proportionality in the dampers of the system. The proportionality adjusts in 4 steps the damper opening or shutting based on the temperature demand of the zone, regulating the flow. It is configured as All/nothing by default.
 

*\*Note: If you change this parameter, all the dampers of the installation will be affected. It is not recommended for RINT and RIC intelligent grilles.*
- **Minimum air** (*only available in installations with AZDI6MZZON [C/R] modules*) and with the parameter "Type of Opening" configured as Proportional). This allows the access of a minimum air flow in zones where the set-point temperature has been already reached. This way, there is a fresh air flow through the air conditioning ducts. If the zone is off, the damper will close completely. It is off by default.
 

*\*Note: If you change this parameter, all the dampers of the installation will be affected. It is not recommended for RINT and RIC intelligent grilles.*
- **Relay settings.** Allows you to modify the logic of operation of CMV/Boiler relay of the main control board (see section *Main control board (AZDI6ACUAZONE / AZDI6BPRO32), Connection*).
- **Boiler temperature** (*only available in installations with AZX6CCP*). Sets a limit temperature for the boiler in order to protect it. Range: 40-65 °C (by default). It is set in 65°C by default.

- **Return temperature** (only available in installations with AZX6SONDPROTEC protection probe). Defines the cut-off temperatures in heating mode (32/34/36°C) and cooling mode (6/8/10 °C) to protect the AC unit. The system highest temperature by default is 34°C and the lowest is 8°C.
- **Radio channel.** It activates/deactivates the Wireless association module of the system.
- **Condensation protection** (only available on installations with cooling radiant control). Enables to select the protection level against condensation: Very high, high, medium, low and very low. If necessary, it can be activated for 1h.
- **Battery temperature.** Allows to set the working limit temperatures of the cooling and heating batteries of the fancoil module ((AZDI6ZMOFAN [C/R]), provided that they are installed.
  - Heating battery: To set the minimum temperature for the water of the heating battery. (Default preset 37 °C)
  - Cooling battery: To set the maximum temperature for the water of the cooling battery. (Default preset 17 °C)
- **Dehumidifier function** (only available in installations with fancoil zone module AZDI6ZMOFAN[C/R], if the temperature probe of the cooling battery AZX6SONDPROTEC is installed). It allows the Dehumidifier function to be enabled in the system, as well as setting the relative humidity limit that is not to be exceeded in the installation. This function allows you to automatically switch to dry mode when the installation is working in cooling mode and the set dehumidification conditions are reached.
- **Automatic mode** (only available in installations with fancoil zone module AZDI6ZMOFAN[C/R] configured as 2 pipes in which the temperature probe of the cooling battery AZX6SONDPROTEC is installed). It allows the Automatic mode function to be activated, thanks to which the system manages the change between cooling/heating mode autonomously. With the automatic mode activated, the option of changing the mode manually from the thermostat is disabled.
- **Reset system** (available only for master thermostat Blueface). Resets the system and returns to factory settings. To reconfigure the thermostats, please check *Initial setup*).

## Think

- **Information.** Displays information about:
  - Zone: Firmware, zone, association, actuator o communications status.
  - System: Firmware, configuration and information about the controllers.
  - Devices: Displays what elements are connected to the system.
  - Webserver: Firmware, IP address, gateway, MAC and PIN.
- **Radio channel.** It activates/deactivates the Wireless association module of the system.

## ZONE SETTINGS

**Important:** To configure the settings for a particular zone of your system from the Blueface thermostat, you must first access that zone from Remote zones.

**Important:** In Think thermostats, press  to confirm and  to return to the previous menu/screen.

- **Zone address** (only available from remote zones, in zones controlled by Lite thermostats). Shows and allows to modify the zone number assigned among the availables.
- **Associated outputs.** It displays and allows you to select the control outputs associated with the thermostat.
- **Thermostat settings** (only available in thermostats Blueface). Use this parameter to define the thermostat as Master as Zone.
 

**\*Note:** It cannot be configured as Master if there is already another Master thermostat (except for 4-pipe installations).
- **Use mode.** The thermostats can be set in Basic or Advanced mode. They are set in Advanced mode by default. These are the parameters you can control in basic mode:
  - On/Off.

- Set-point temperature.
- Fan Speed.
- Operation mode (*only available for zone thermostats in installations configured as four-pipe*).

If you need to reset the thermostat to Advanced mode, access the advanced configuration menu and then activate the advanced use mode.

- **Control stages** (*Only on installations with AZDI6OUTPUT8*). This parameter is used to configure both cooling and heating stages in a single zone or in all the zones. These are the features to be configured:
  - **Air:** Enables air heating/cooling in the selected zone and allows the user to select the type of production available in the zone (direct expansion or water unit).
  - **Radiant:** It activates radiant heating/cooling.
  - **Combined:** It activates both air and radiant heating/cooling in the zone selected and also allows the user to select the desired heating stage: Air, radiant or combined (see section *Zone settings - Blueface Thermostat, Control stages*). The zone will start using the heating air stage. Once the room temperature reaches the differential pre-established (see parameter *Hysteresis Conf.*), the zone will activate the radiant stage.
  - **Off:** It deactivates the cooling/heating stage in the zone.
- **Offset.** Allows you to correct ambient temperature that is measured in the various areas or in all of them, due to deviations by sources of heat/cold nearby, with a correction factor between - 2,5°C and 2,5°C in steps of 0,5°C. It is in 0°C by default.
- **Presence contact.** It determines the state of the module of a zone based on the occupancy. It only has effect on the zone control module if it is associated to a thermostat (it does not operate in secondary zone modules). When this contact is on, if the zone is empty for over 5 minutes, the Sleep 90 feature is activated (displaying an Occupancy notification on the thermostat). It is off by default. In order to activate this feature, configure it as Normally open or Normally closed.
- **Window contact.** This option allows the control the state of a zone module based on the opening of the window. It only has effect on the control element of the zone module. When this contact is on, if it detects any open window, it turns off the zone after 60 seconds (displaying an Open window notification on the thermostat). It is off by default. In order to activate this feature, configure it as Normally open or Normally closed.
- **Master address** (*only available in installations configured as 4-pipe installations*). This menu allows you to determine the operation mode of operation defined in a different master zone. That way, the zone will only control set-point temperature and fan speed features. It is off by default.
- **Q-Adapt configuration.** Defines the individual weight of each zone to adapt the flow of the unit to the zone needs. These are the features to be configured:
  - **Automatic.** Default value. The system distributes proportionally its total weight (100) among the zone modules in which the air stage is available.
  - **Manual.** It allows you to change the total weight of the zone. The weight displayed is the total of the main and secondary zone modules. Range of values: 1-100 (accuracy: ±1).  
 \***Note:** *Total system weight may exceed 100.*

The logic behind the change of speed of the AC units gateways of the system according to the weights is as follows:

	2 speeds	3 speeds	4 speeds	5 speeds
Speed 1	1 – 50	1 – 34	1 – 25	1 – 20
Speed 2	51 – 100	35 – 67	26 – 50	21 – 40
Speed 3	-	68 – 100	51 – 75	41 – 60
Speed 4	-	-	76 – 100	61 – 80
Speed 5	-	-	-	81 – 100

The output voltage for manual speeds is as follows:

	Output voltage
Speed 1	4 V
Speed 2	7 V
Speed 3	10 V

**Important:** In 0-10 V fancoil gateways the output voltage is:

$$\text{Output V} = \frac{\sum \text{Weight of zones with thermal demand}}{10}$$

The change of the fan speed depends on the configuration and typology of each zone of the installation. For further information, please refer to the system's installation manual.

- **Eco function.** (Only available in installations with fancoil zone module AZDI6ZMOFAN [C/R]). Modify the setpoint temperature (+/- 2.5 °C) for more efficient management of the thermal demand in its zone.
- **Steady ventilation.** (Only available in installations with fancoil zone module AZDI6ZMOFAN [C/R]). This allows system ventilation to be maintained even when no demand is being generated. This function is configured independently in the heating and cooling modes.
- **DC fan voltage.** (Only available in installations with fancoil zone module AZDI6ZMOFAN [C/R]). This system function allows fan speeds to be adjusted according to the voltage specifications of the fancoil manufacturer.
- **Manufacturer ID** (only available in installations with AZDI6MCIFRC modules). Select the control protocol you want to use in the AC unit to be controlled.

Check the compatible IR gateway modules at:

[http://doc.airzone.es/producto/Gama\\_AZ6/Airzone/Distribuido/Fichas\\_tecnicas/Compatibilidades/UC\\_AZDI6MCIFR\\_MUL.pdf](http://doc.airzone.es/producto/Gama_AZ6/Airzone/Distribuido/Fichas_tecnicas/Compatibilidades/UC_AZDI6MCIFR_MUL.pdf)

- **Reset thermostat** (not available in remote zones). Resets the thermostat returning to Setup menu (see section *Initial setup*).

## PRODUCTION SETTINGS

**Important:** Production control board settings are only available in AZX6CCPGAWI for the master Blueface thermostat of the system nº1.

- **Operation logic.** It allows to configure the operation logic for the control relays of the production control board:
  - Aerothermal unit (Default preset)
  - 2 pipes
  - 4 pipes
  - RadianT (Recommended for RadianT365 systems)
  - Aerothermal

Mode	Demand	Control Relays					
		FRIO_Y	CALORB_W	AIRE_Y	RADIANTE_Y	AIRE_W	RADIANTE_W
Stop	Off	--	--	--	--	--	--
Cooling mode	Air	ON	--	ON	--	--	--
	Radiant	ON	--	--	ON	--	--
	Off	--	--	--	--	--	--
Heating mode	Air	--	ON	--	--	ON	--
	Radiant	--	ON	--	--	--	ON
	Off	--	--	--	--	--	--
Dry	On	--	--	--	--	--	--
	Off	--	--	--	--	--	--
Ventilation	On	--	--	--	--	--	--
	Off	--	--	--	--	--	--

- 2 pipes / 4 pipes

Mode	Demand	Control Relays					
		FRIO_Y	CALORB_W	AIRE_Y	RADIANTE_Y	AIRE_W	RADIANTE_W
Stop	Off	--	--	--	--	--	--
Cooling mode	Air	ON	--	ON	--	--	--
	Radiant	ON	--	--	ON	--	--
	Off	ON	--	--	--	--	--
Heating mode	Air	--	ON	--	--	ON	--
	Radiant	--	ON	--	--	--	ON
	Off	--	ON	--	--	--	--
Dry mode	On	ON	--	--	--	--	--
	Off						
Ventilation	On	--	--	--	--	--	--
	Off						

**Note:** In this configuration, the indoor unit will remain in Standby mode once comfort has been reached in all zones

- **Activation delay.** It allows to set a delay time in the power on of the production unit, configurable in minutes, from 0 to 7. (Default preset to 3 minuts).
- **LWT temperatures.** (Only available in installations with gateway AZX6GAW[XXX] provided that the aerothermal unit is not configured to work automatically, allowing the imposition of working temperatures). It allows to set the LWT temperaturas for the heating and cooling modes of the aerothermal unit. Selectable values depends on each particular aerothermal unit. Default presets are:
  - Air in cooling mode: 10 °C
  - Radiant in cooling mode: 18 °C
  - Air in heating mode: 50 °C
  - Radiant in heating mode: 35 °C
- **DHW function.** (Only available in installations with AZX6GAWXXX control gateways) It allows to turn on/off the Domestic Heat Water (DHW) function in the systems connected to the CCP. Activated by default.
- **Cooling mixing valve** (only available in installations with aerothermal gateway). It allows you to configure the operation of your installation depending on whether or not you have a cooling mixing valve.

Select Manual in the case of having cooling mixing valves in your installation, in which case they must be set at 18°C. If the installation does not have a cooling mixing valve, select Auto so that the installation works automatically with the temperature read by the system. By default it is set as Manual.

## SELF-DIAGNOSE

### AIRZONE MAIN CONTROL BOARD (AZDI6ACUAZONE / AZDI6IBPRO32)

Airzone main control boards have integrated LEDs that detect unusual operations.

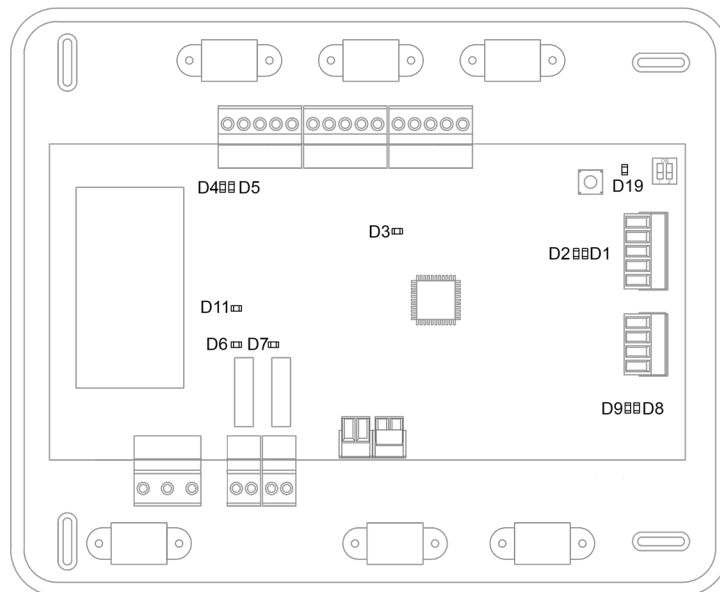

Meaning			
D1	Data reception from automation bus	Blinking	Green
D2	Data transmission from automation bus	Blinking	Red
D3	Main control board activity	Blinking	Green
D4	Data transmission from Airzone Connection Bus	Blinking	Red
D5	Data reception from Airzone Connection Bus	Blinking	Green
D6	AC unit On/Off	Switches	Green
D7	CMV/Boiler	Switches	Green
D8	Data transmission from AC unit bus	Blinking	Red
D9	Data reception from AC unit bus	Blinking	Green
D11	Main control board power supply	Steady	Red
D19	Association channel: active	On	Red

## AIRZONE WIRED/WIRELESS ZONING MODULES (AZDI6MZZON [C/R] AND AZDI6MZSRE [C/R])

The Airzone wired/wireless Zoning Modules have integrated LEDs that detect unusual operations.

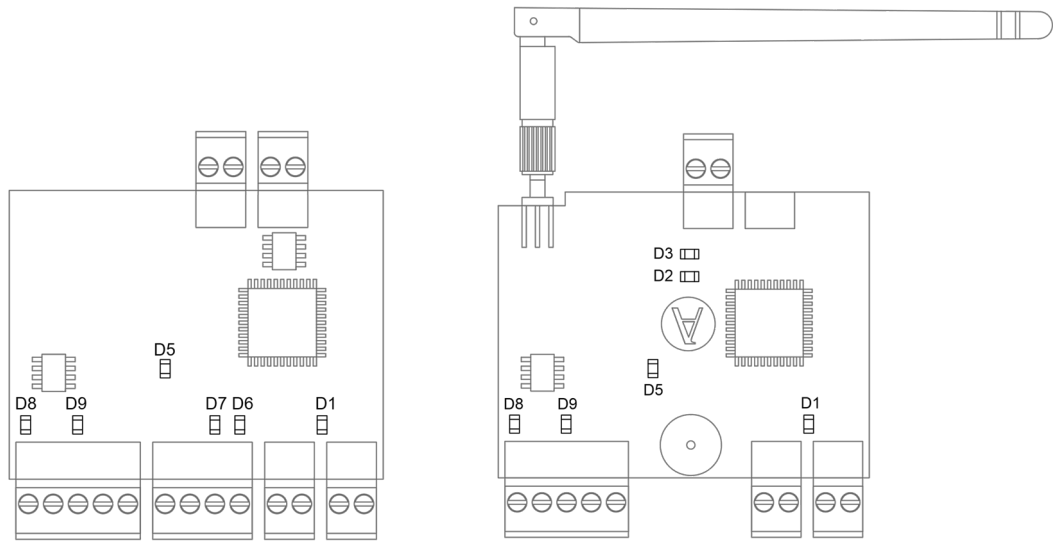

**AZDI6MZZONC and AZDI6MZSREC**

**AZDI6MZZONR and AZDI6MZSRER**

Meaning			
D1	Module operating	Blinking	Green
D2	Wireless data packets reception	Switches	Green
D3	Association channel: active	Solid	Red
D5	Power supply	Solid	Red
D6	Data reception from thermostat	Blinking	Green
D7	Data transmission from thermostat	Blinking	Red
D8	Data reception from Airzone connection bus	Blinking	Green
D9	Data transmission from Airzone connection bus	Blinking	Red

## AIRZONE FANCOIL INDIVIDUAL UNIT ZONE MODULE WIRED/WIRELESS (AZDI6ZMOFAN [C/R])

The Airzone Fancoil Gateway Modules have integrated LEDs that detect unusual operations.

**AZDI6ZMOFANC**

**AZDI6ZMOFANR**

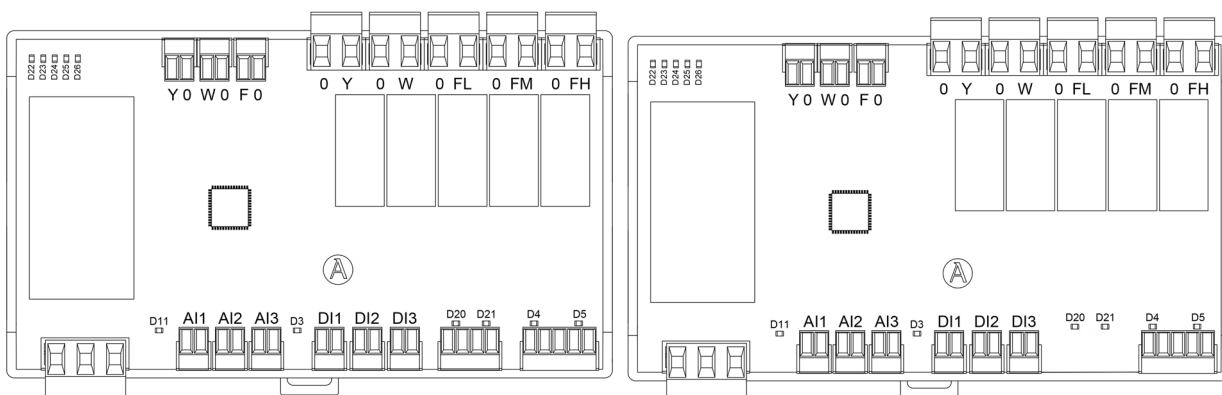

Meaning			
D3	Module operating	Blinking	Green
D4	Data transmission from Airzone connection bus	Blinking	Red
D5	Data reception from Airzone connection bus	Blinking	Green
D11	Power supply	Solid	Red
D20	Data transmission from thermostat	Blinking	Red
D21	Data reception from thermostat	Blinking	Green
D22...D26	Leds of relay state	Switches	Green

The meaning for the LEDs D20 and D21 in the Wireless module AZDI6ZMOFANR is different, accordingly to the figure below.

Meaning			
D20	Association channel: active	Blinking	Red
D21	Data reception by radio	Blinking	Green

### WIRED/WIRELESS GATEWAY MODULE (AZDI6MC XXX [C/R])

The Airzone Gateway Modules have integrated LEDs that detect unusual operations.

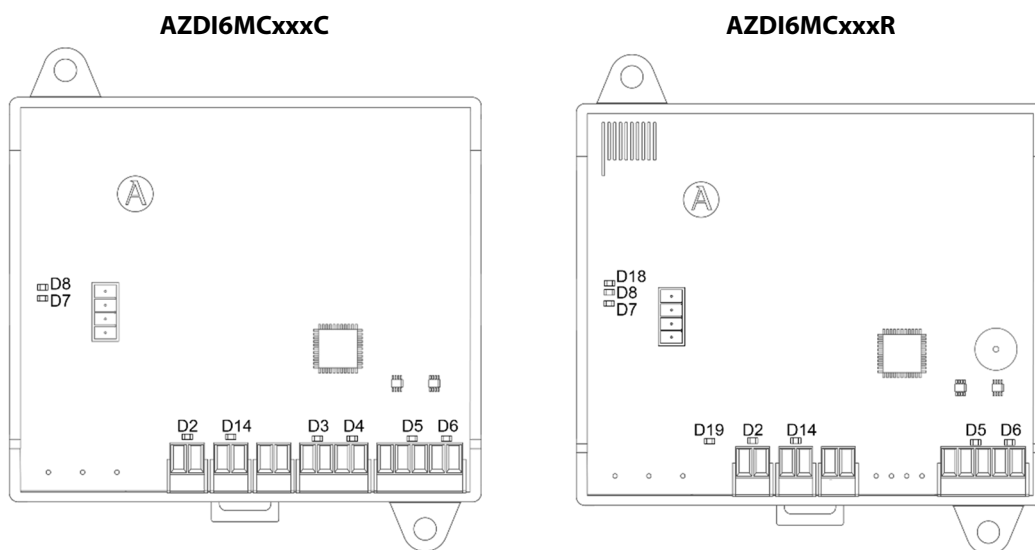

Meaning			
D2	Power supply	Solid	Red
D3	Data transmission from thermostat	Blinking	Red
D4	Data reception from thermostat	Blinking	Green
D5	Data transmission from Airzone Connection Bus	Blinking	Red
D6	Data reception from Airzone Connection Bus	Blinking	Green
D7	Data transmission from gateway	Blinking	Red
D8	Data reception from gateway	Blinking	Green
D14	Module activity	Blinking	Green
D18	Wireless data packets reception	Switches	Green
D19	Association channel: active	On	Red



## WIRED/WIRELESS GATEWAY MODULE (AZDI6MC XXX [C/R])

The Airzone Gateway Modules have integrated LEDs that detect unusual operations.

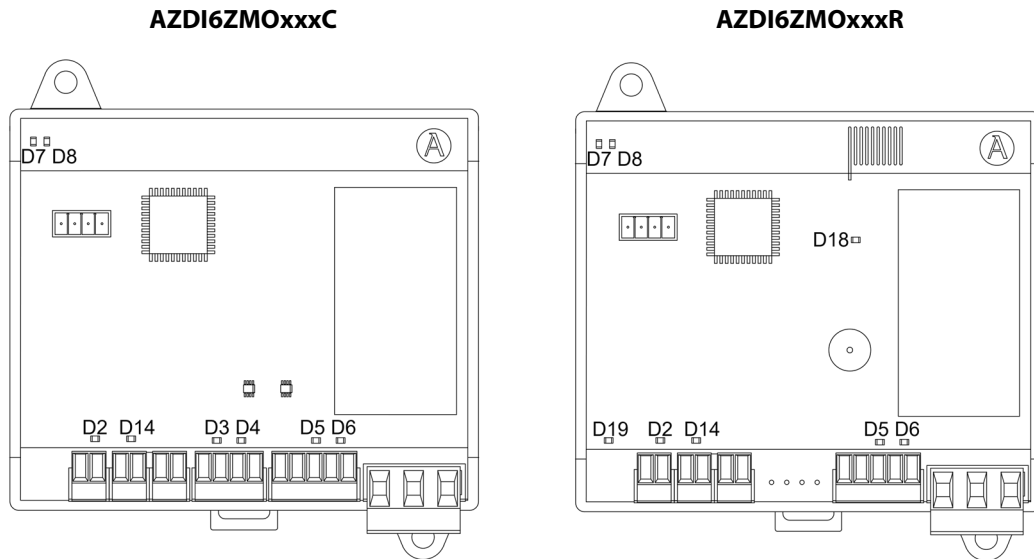

Meaning			
D2	Power supply	Solid	Red
D3	Data transmission from thermostat	Blinking	Red
D4	Data reception from thermostat	Blinking	Green
D5	Data transmission from Airzone Connection Bus	Blinking	Red
D6	Data reception from Airzone Connection Bus	Blinking	Green
D7	Data transmission from gateway	Blinking	Red
D8	Data reception from gateway	Blinking	Green
D14	Module activity	Blinking	Green
D18	Wireless data packets reception	Switches	Green
D19	Association channel: active	On	Red

## AIRZONE INFRARED GATEWAY MODULE WIRED/WIRELESS (AZDI6MCIFR [C/R])

The Airzone Infrared Gateway Modules have integrated LEDs that detect unusual operations.

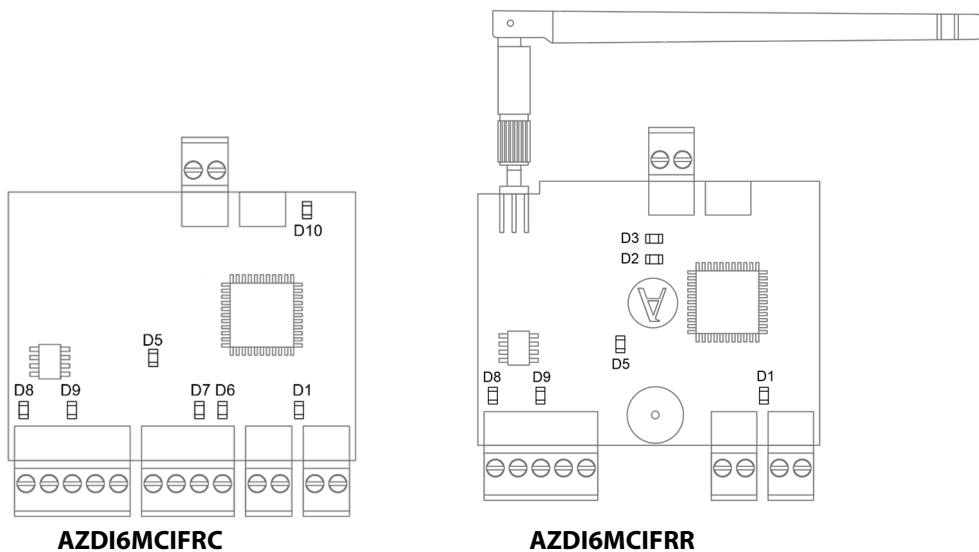

Meaning			
D1	Module activity	Blinking	Green
D2	Wireless data packets reception	Switches	Green
D3	Association channel: active	Solid	Red
D5	Power supply	Solid	Red
D6	Data reception from thermostat	Blinking	Green
D7	Data transmission from thermostat	Blinking	Red
D8	Data reception from Airzone Connection Bus	Blinking	Green
D9	Data transmission from Airzone Connection Bus	Blinking	Red
D10	IR data transmission	Blinking	Red

### AIRZONE CONTROL MODULE OF RADIANT ELEMENTS (AZDI6OUTPUT8)

Airzone control modules have LEDs integrated in order to detect malfunctions.

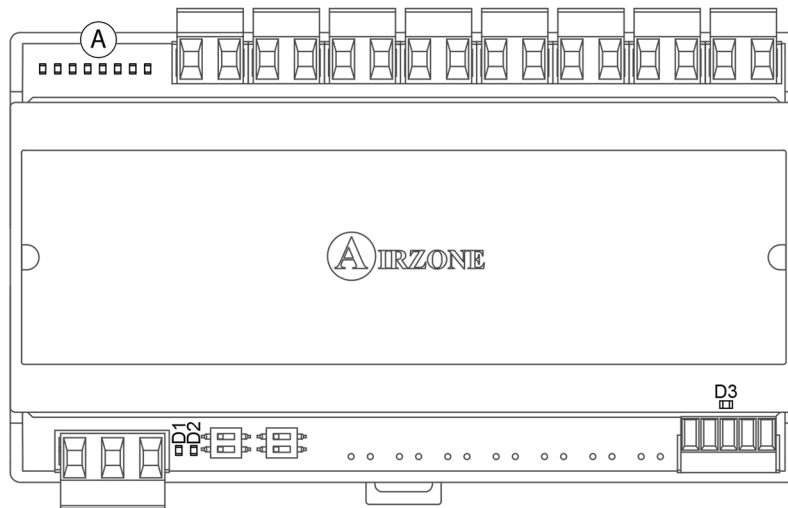

Meaning			
D1	Power supply	Solid	Red
D2	Module is operating	Blinking	Green
D3	Transmitting and receiving data from Airzone connection bus	Blinking	Green
(A)	Relay status LEDs	Switches	Green

## AIRZONE BLUEFACE AND THINK THERMOSTATS (AZDI6BLUEFACEC / AZDI6THINK [C/R])

### Blueface and Think Thermostat Warnings

Thermostat displays all the system warnings on the screensaver. If there is any error, it will be displayed on the screensaver, on the main screen and on "Errors", in user settings.

- **Anti-freezing.** It will be only displayed when it is activated. (See *Zone settings – Blueface thermostats*).
- **Window.** It indicates the air conditioning of the zone has been deactivated due to open window. Only available if the window contact of the system is activated.
- **Occupancy.** It indicates no occupancy has been detected in the zone for the last 5 minutes. Therefore, the Sleep mode is activated (the zone will switch off after 90 minutes). Only available for systems with occupancy control.
- **Humidity.** It indicates there is a risk of condensation and that the radiant stage is off in the zone. If your systems include air stage, it will activate it to reduce the humidity level and it will activate the On/Off relay of the Acuazone/Innobus Pro32 main control board (see section *Self-diagnose, Main Control Board (AZDI6ACUAZONE / AZDI6BPRO32)*). This feature is only available for systems with radiant stage in cooling mode.
- **Active dew protection.** It indicates there is a risk of condensation in the radiant stage and the air stage has been activated to avoid its creation.
- **DHW.** DHW is active. If your system has DHW management and it is activated, you will see a message on your Blueface screensaver and the zone will be deactivated.
- **Low Battery Lite** (*only Blueface*). Low battery warning. Informs about the involved zone when the icon is pressed.
- **Dew Lite** (*only Blueface*). It indicates there is a risk of condensation and the zone where the Lite thermostat is located has been turned off. Press the icon to know which zone is affected.
- **Lite dew protection.** It indicates there is a risk of condensation in the radiant stage and the air stage has been activated to avoid its creation in the Lite zone.
- **Preparing.** This warning indicates that the heating/cooling battery is outside the temperature limits configured, and therefore ventilation will be deactivated until the working temperature required to satisfy demand is reached.
-  **Battery** (*only Think wireless*). Low battery warning.



### Blueface and Think Thermostats errors

If any type of anomaly is detected, the word "Error" is displayed on the screensaver of these devices. You may find the following errors:

#### **Error 1: Failure of the communications between thermostat and control module**

**(AZDI6MZZONC / AZDI6MZSREC / AZDI6MCIFRC / AZDI6ZMOFANC / AZDI6MCxxxC / AZDI6ZMOxxxC)**

This incident blocks the control of the zone. To solve this incident check:

1. Connection: Check the polarity of the connectors of the module and the thermostat.
2. Wiring: Check that the voltage between the poles is correct (1.8 Vdc).
3. Wiring: Verify that the module connection bus-thermostat is not next to low-voltage wiring.
4. Module: Check the correct operation of the module, for this connect another thermostat and verify that the error disappears.
5. Restart the zone and re-associate it with the system:
  - Blueface thermostats: Press on Reset to restart the device. If the error persists, press and hold on  and reset the thermostat. Configure the system.
  - Think thermostats: To do this, press and hold on  and restart the start-up configuration process.
6. Restart system: If the system is restarted, this error may be displayed in the thermostats at the beginning of the process. This message should disappear after around 30 seconds.

**AZDI6MZZONC / AZDI6MZRREC / AZDI6MCIFRC**

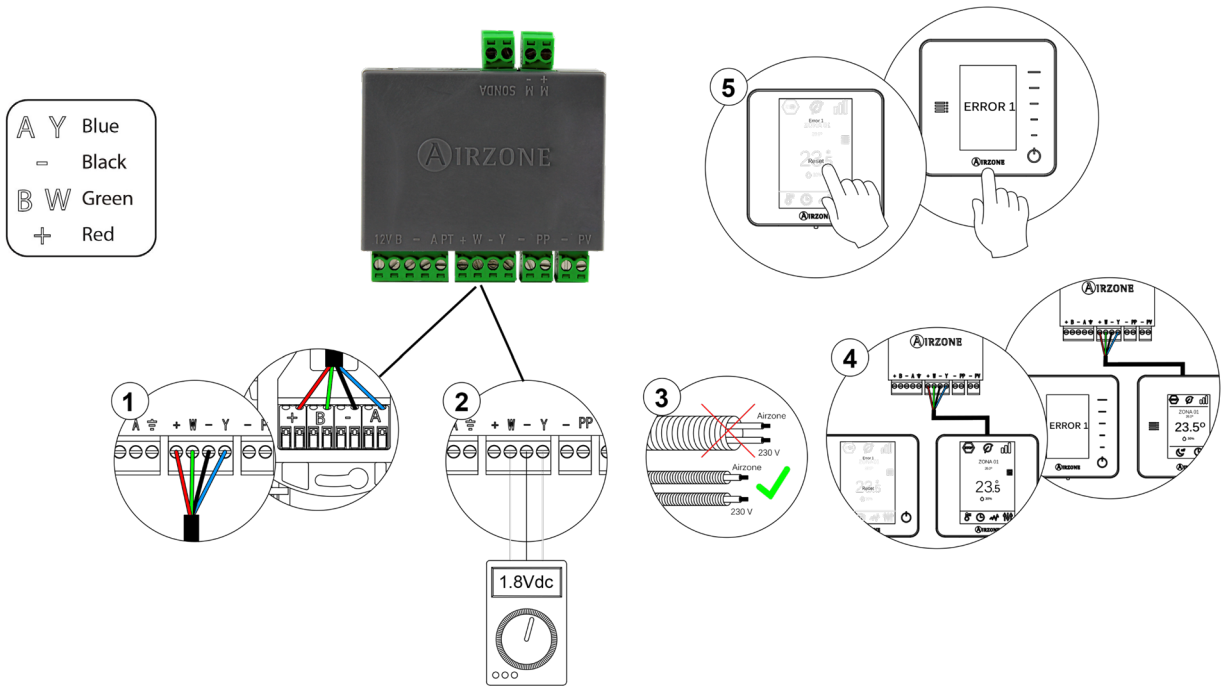

**AZDI6ZMOFANC**

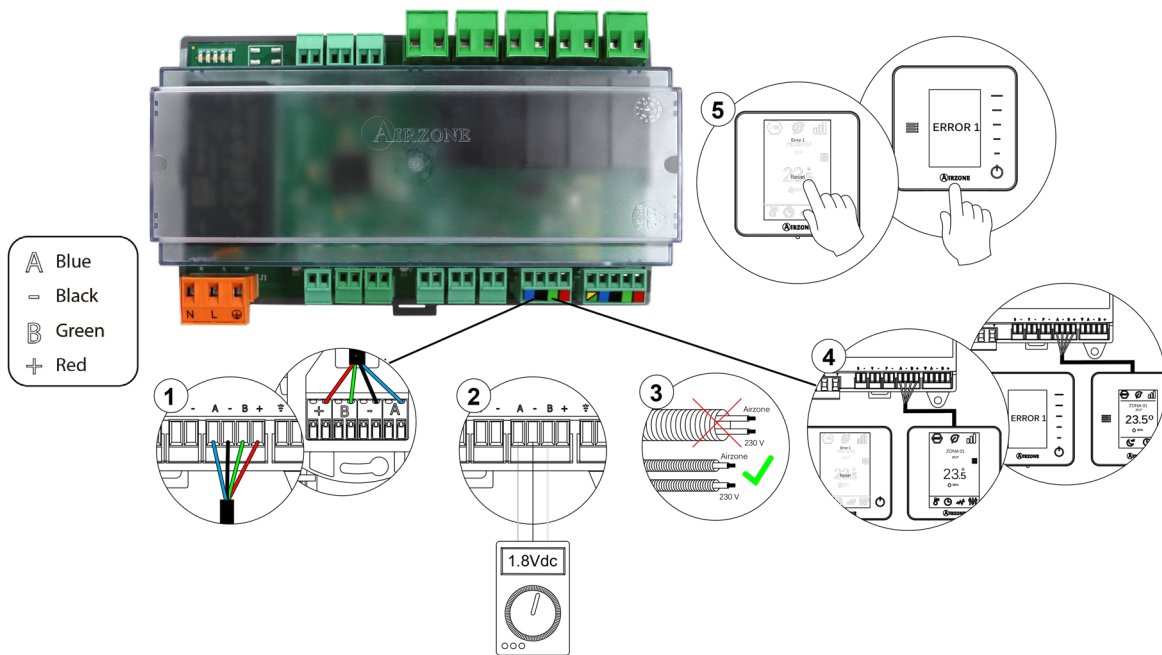

### AZDI6MCxxxC

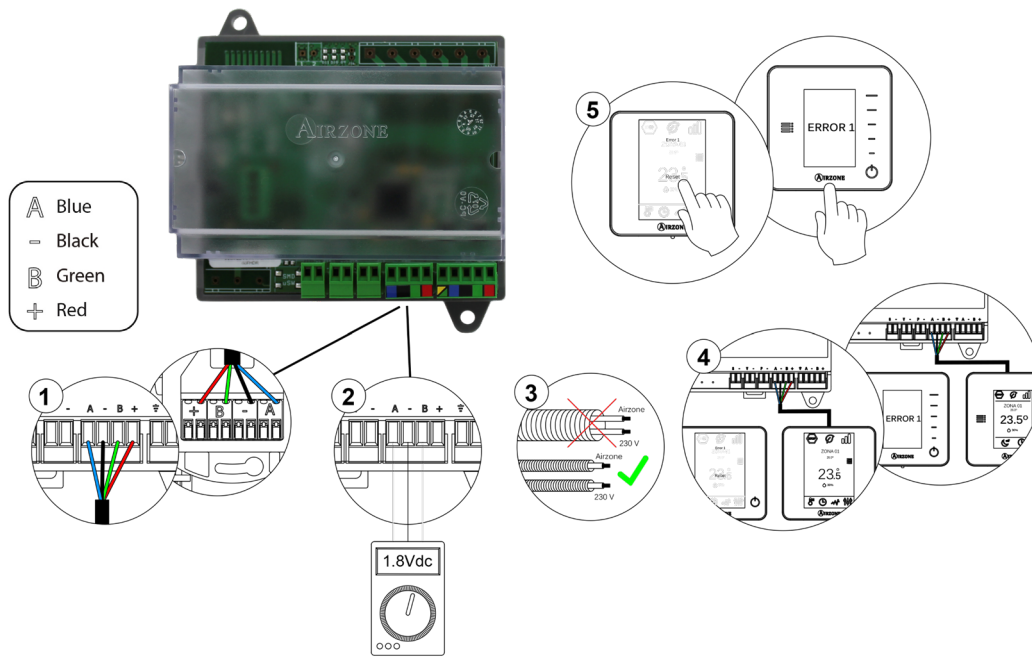

### AZDI6ZMOxxxC

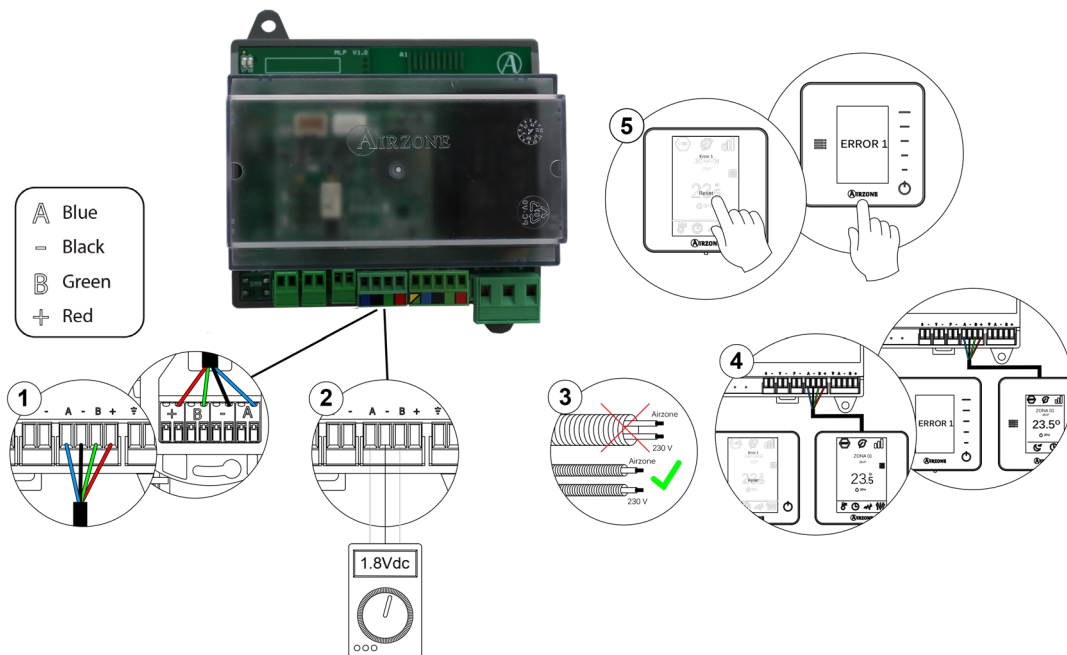

**Error 1: Failure of communications between wireless thermostat and control module**

(AZDI6MZZONR / AZDI6MZSRER / AZDI6MCIFRR / AZDI6ZMOFANR / AZDI6MCxxxR / AZDI6ZMOxxxR)

This incident blocks the control of the zone. To solve this incident check:

1. Thermostat status: Check the signal range of the thermostat with the module through the Information parameter (see section *Advanced settings, system settings*) or approach the thermostat to the module if the thermostat recovers the communication, it is necessary to relocate it as it was out of range.
2. Module status: Correctly powered.
3. Module status: Proper operation of the LED of wireless communication.
4. Restart the zone and re-associate it with the system. To do this, press and hold on and restart the start-up configuration process. Note that, if you need to associate wireless devices, the wireless association module must be previously open (from SW1 button or from any thermostat, pressing *Wireless module* inside *Advanced Settings, zone settings*).
5. Restart system: If the system is restarted, this error may be displayed in the thermostats at the beginning of the process. This message should disappear after around 30 seconds.

**AZDI6MZZONR / AZDI6MZSRER / AZDI6MCIFRR**

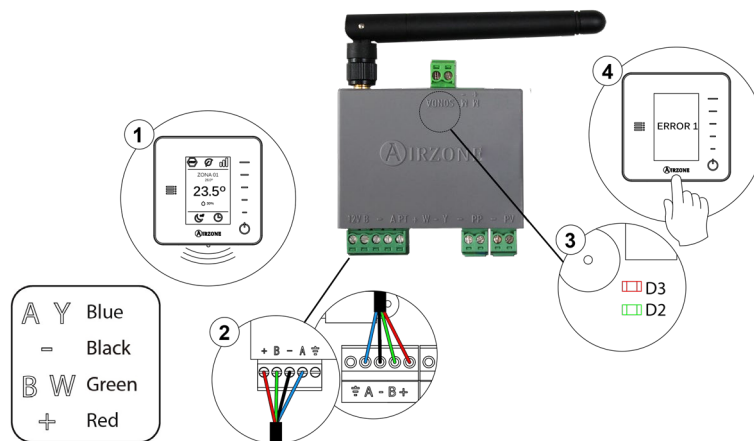

**AZDI6ZMOFANR**

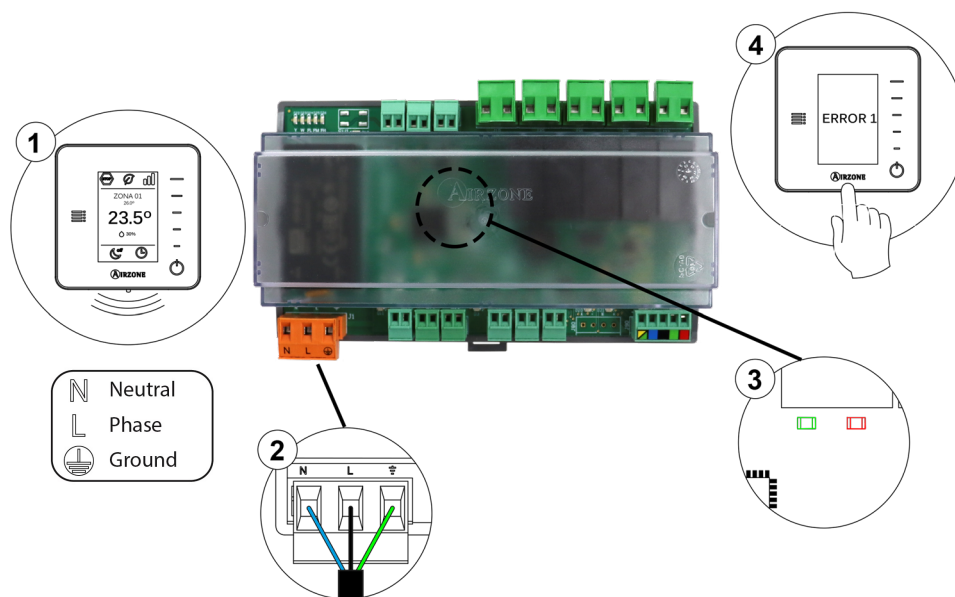

### AZDI6MCxxxR

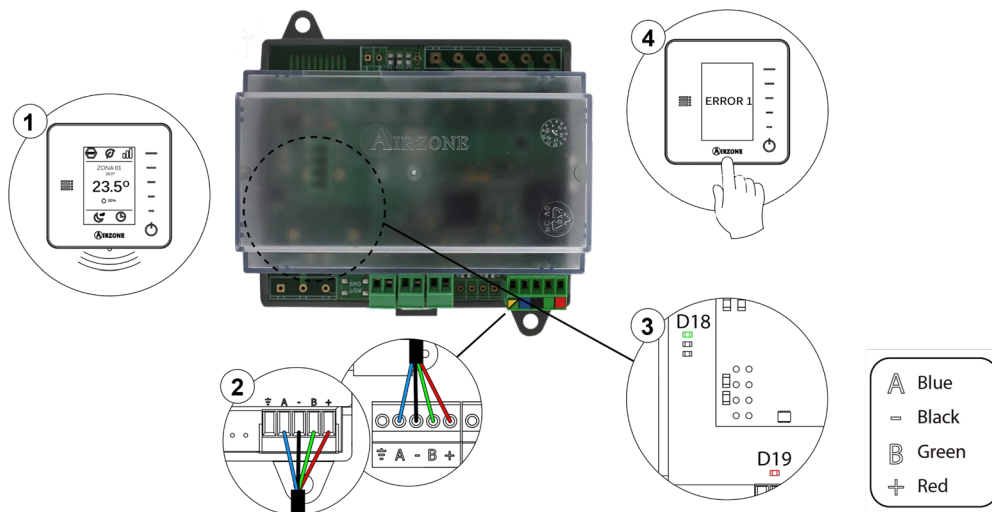

### AZDI6ZMOxxxR

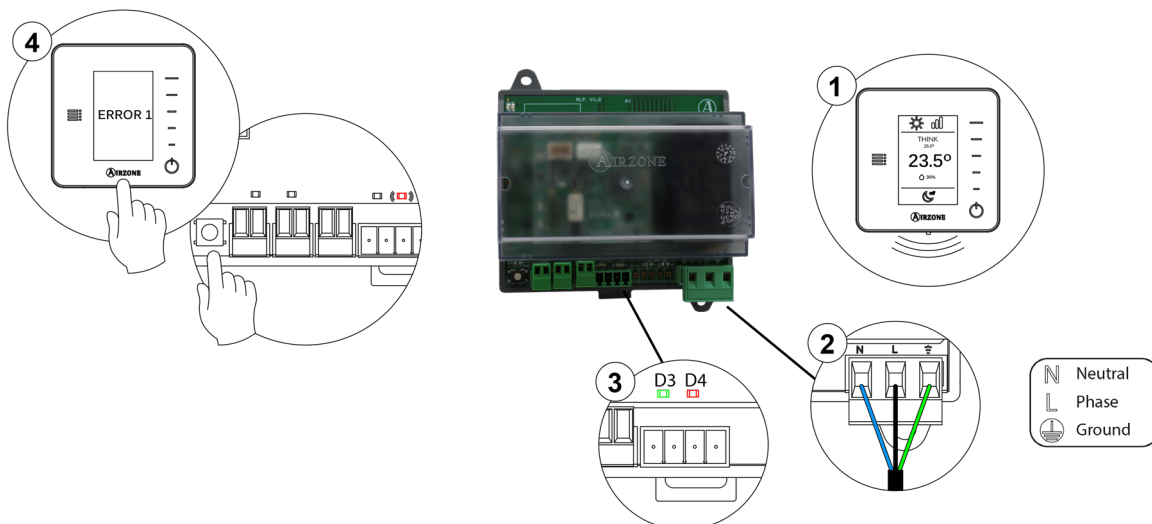

### Error 2: Failure of communications between main control board and control module (AZDI6MZZON [C/R] / AZDI6MZSRE [C/R] / AZDI6MCIFR [C/R] / AZDI6ZMOFAN [C/R] / AZDI6MCxxx [C/R])

This incidence only allows the control of the zone for Individual Unit Zone Module (AZDI6MCxxx [C/R]), for the remaining elements, the control of the zone is not allowed. Check this error is not common to all thermostats. If so, verify the proper operation of the main board. To solve this incident check:

1. Main control board status: Correctly powered.
2. Main control board status: Airzone Connection Bus LEDs are operating properly.
3. Connection: Verify the polarity of the main control board and thermostat connectors.
4. Wiring: Check that the voltage between the poles (A/-) and (B/-) is correct (1.8 Vdc).
5. Restart the zone and re-associate it with the system:
  - Blueface thermostats: Press on Reset to restart the device. If the error persists, press and hold on and reset the thermostat. Configure the system.
  - Think thermostats: To do this, press and hold on and restart the start-up configuration process.



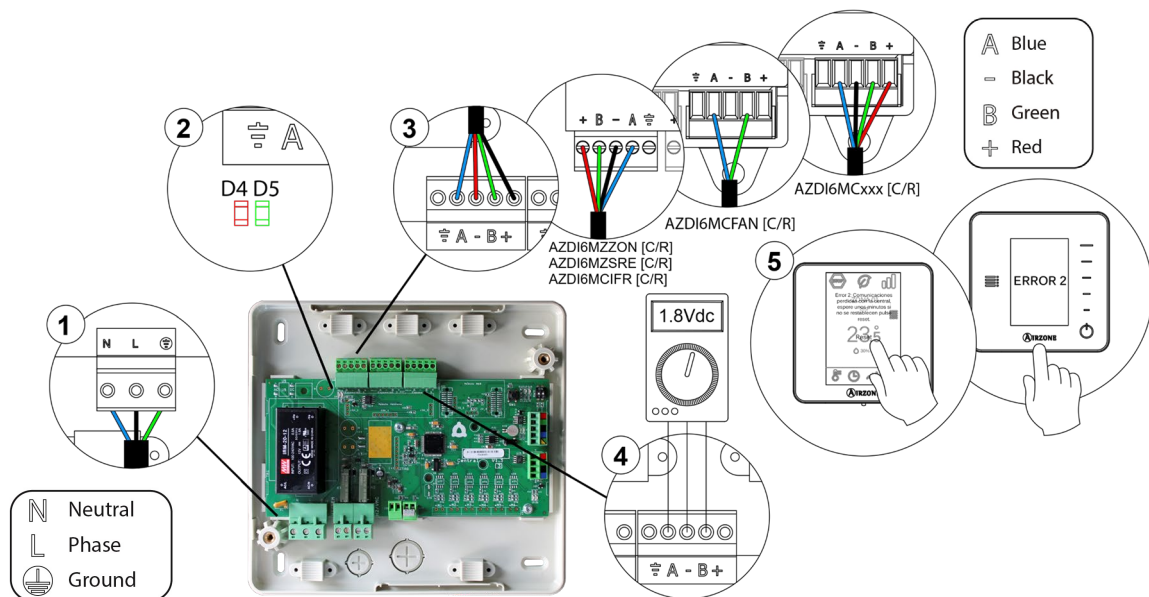

### Error 3: Motorized element not connected to the actuator output

The system does not detect any motorized element connected to the motor output. Check the state of the connection terminal of the actuator output of the zone module:

1. Status of the connection terminal in the actuator output of the zone module.
2. Disconnect and connect the terminal of the Airzone connection bus.

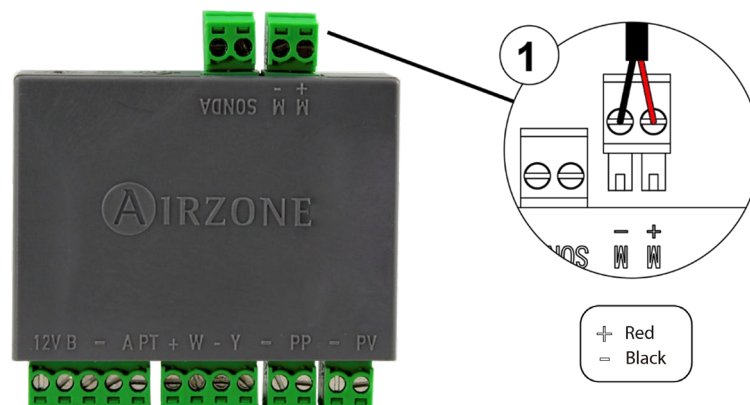

### Error 4: Motorized element blocked

The system detects that the motorized element has an abnormality and blocks the opening-closing movement. Disconnect and connect the Airzone connection bus terminal and check if the error disappears, otherwise, proceed to the replacement of the device or sent it for repair.

### Error 5: Temperature probe - Open circuit

The zone ceases to measure the room temperature; therefore, the zone cannot generate demand. Proceed to replace it of the device or sent it for repair.

### Error 6: Temperature probe - Short circuit

The zone ceases to measure the room temperature; therefore, the zone cannot generate demand. Proceed to replace it of the device or sent it for repair.



**Error 9: Gateway-System communication error**

The system loses communication with the AC unit. The system will open all the zones and deactivate the control from the thermostats, only allowing the operation of the unit from the thermostat of its manufacturer. To solve this incidence, please check the following steps depending on the device:

1. Verify the gateway is properly connected to the AC unit port of the main control board.
2. In DIN-rail gateways, check the polarity of the connectors of the gateway and the AC unit port of the main board.
3. Check the status of the LEDs of the gateway. To do this check the self-diagnose section or the technical sheet of the gateway.

**AZDI6ACUAZONE / AZDI6IBPRO32**

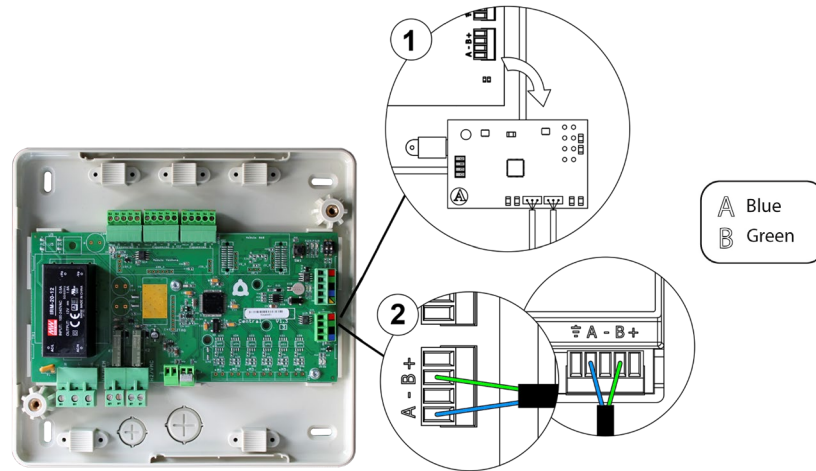

**AZDI6MCxxx [C/R] / AZDI6ZMOxxx [C/R]**

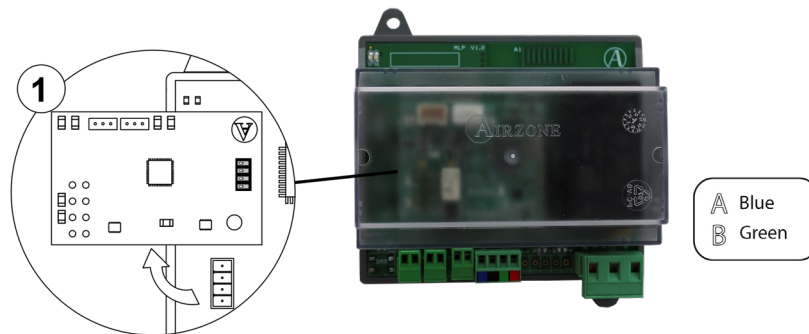

**Error 10: Communication error between BACnet Integration Gateway – Systems**

The system loses communication with the Airzone BACnet Interface. Check that the gateway is properly connected to the automation bus of the Main Board..

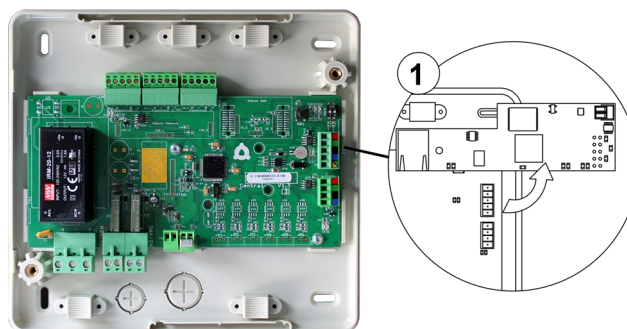

### Error 11: Gateway-AC Unit communication error

The system loses communication with the AC unit. The system will open all the zones and deactivate the control from the thermostats, only allowing the operation of the unit from the thermostat of its manufacturer. To solve this incidence, please check the following steps depending on the device:

1. Verify if the Air unit is powered. To do this, check the thermostat of the AC unit is ON.
2. Verify the AC unit operates properly by itself. To do this, disconnect the A/C unit Airzone system and select the unit from the thermostat from the A/C unit.
3. Connection: Check the polarity and connection of the gateway connectors and the indoor unit. Consult the technical sheet of the gateway in question.
4. Wiring: In DIN-rail gateways, check that the voltage between the poles (A/ -) and (B/ -) is correct (1.8 Vdc).
5. Verify the status of the LEDs of the gateway is correct. To do this check the self-diagnose section or the technical sheet of the gateway.

#### AZDI6ACUAZONE / AZDI6IBPRO32

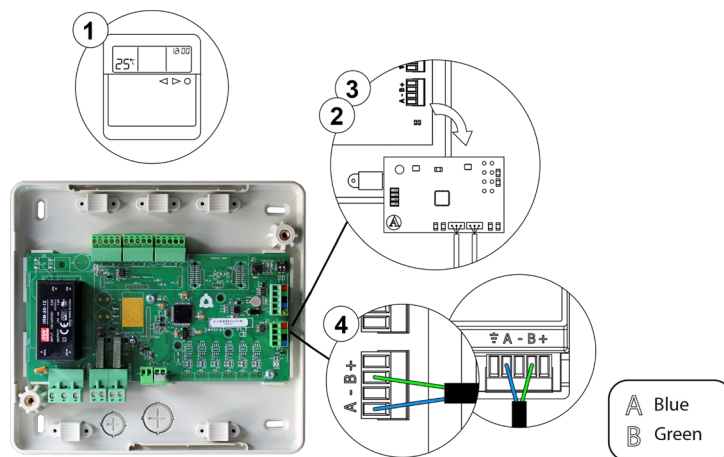

#### AZDI6MCxxx [C/R] / AZDI6ZMOxxx [C/R]



**Error 12: Communication error between Airzone Cloud Webserver – system**

The system loses communication with the Webserver. Check that the Webserver is correctly connected to the Control board’s automation bus.

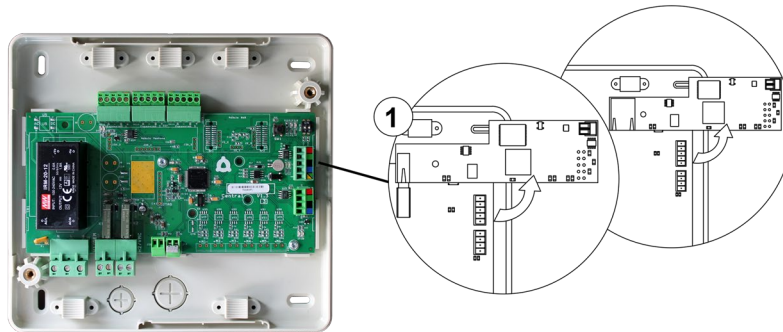

**Error 13: Main Board-Control module of radiant elements communication error**

The device cannot be controlled by the system. To solve this incident check:

1. Status of the control module of the radiant elements: Correctly powered.
2. Status of the control module of the radiant elements and the main control board: Airzone Connection Bus LEDs are operating properly.
3. Connection: Check the polarity of the connectors of the main control board and the radiant element board.
4. Wiring: Check that the voltage between the poles (A/-) and (B/-) is correct (1.8 Vdc).

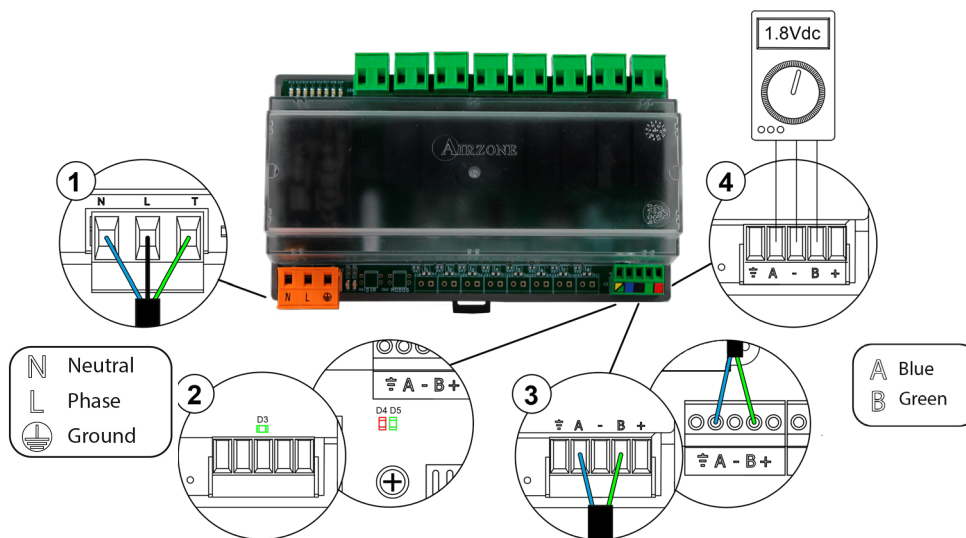

**Error 17: Communication error between Lutron Integration Gateway – System**

The system loses communication with the Airzone Lutron Interface. Check that the gateway is properly connected to the automation bus of the Main Board.

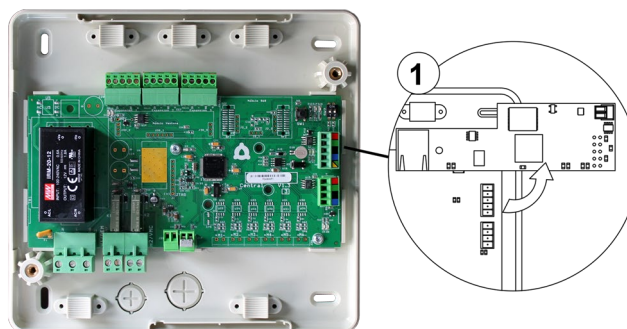

**Error C02: Main Control Board – Production Control Board communication error**

This incident blocks the control of the zone. To solve this incident check:

1. Status of the control module of the radiant elements: Correctly powered.
2. Status of the Main Control Board: Expansion bus LEDs are operating properly.
3. Connection: Check the polarity of the connectors of the CCP and the Main Control Board of the system.

**AZX6CCP**

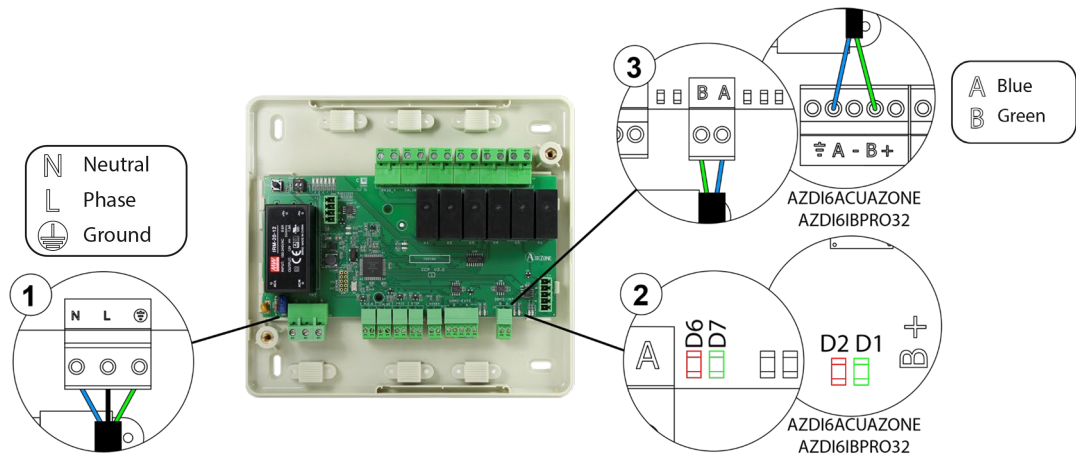

**Error C09: Aerothermal Gateway-Production Control Board Communication Error**

The system loses communication with the Gateway and, therefore, with the aerothermal system. The control of the system will be disabled, enabling the system to work from the manufacturer’s thermostat. To solve this incident check:

1. Verify that the Gateway is properly connected to the unit port of the Production Control Board.
2. Check the status of the LEDs of the gateway. To do this check the self-diagnose section or the technical sheet of the gateway.

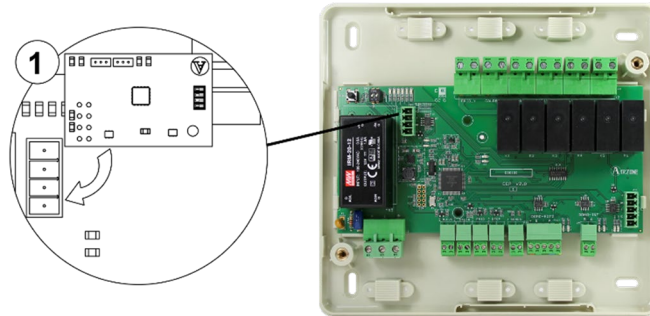

**Error F05-H: Heating battery temperature probe - Open circuit** *(Only available in AZDI6BLUEFACEC)*

The system ceases to measure the temperature of the heating battery; therefore, the Automatic Mode and the battery temperature reading are not available. Proceed to replace it of the device or sent it for repair.

**Error F05-C: Cooling battery temperature probe - Open circuit** *(Only available in AZDI6BLUEFACEC)*

The system ceases to measure the temperature of the cooling battery; therefore, the Automatic Mode, Dehumidifier Function and the battery temperature reading are not available. Proceed to replace it of the device or sent it for repair.

**Error F06-H: Heating battery temperature probe - Short circuit** *(Only available in AZDI6BLUEFACEC)*

The system ceases to measure the temperature of the heating battery; therefore, the Automatic Mode and the battery temperature reading are not available. Proceed to replace it of the device or sent it for repair.

**Error F06-C: Cooling battery temperature probe - Short circuit** *(Only available in AZDI6BLUEFACEC)*

The system ceases to measure the temperature of the cooling battery; therefore, the Automatic Mode, Dehumidifier Function and the battery temperature reading are not available. Proceed to replace it of the device or sent it for repair.

**Error F0506-HC: Heating or cooling battery temperature probe - Short circuit / Open circuit** *(Only available in AZDI6THINK [C/R])*

The system ceases to measure the temperature of the cooling or heating battery; therefore, the Automatic Mode, Dehumidifier Function and the battery temperature reading are not available. Proceed to replace it of the device or sent it for repair.

**AC unit error: Error in the AC unit**

Check the type of error in the AC unit thermostat and follow the instructions provided by the manufacturer.

## AIRZONE LITE THERMOSTATS (AZDI6LITE [C/R])

Lite thermostats incorporate LEDs that detect malfunctioning.

**Status LED  blinking purple quickly: Lite thermostat- control module communication error (AZDI6MZZONC / AZDI6MZRSEC / AZDI6MCIFRC / AZDI6ZMOFANC / AZDI6MCxxxC)**

This incident blocks the control of the zone. To solve this incident check:

1. Thermostat status: Check the polarity of the connectors of the module and the thermostat.
2. Wiring: Check that the voltage between the poles is correct (1.8 Vdc).
3. Wiring: Verify that the module connection bus-thermostat is not next to low-voltage wiring.
4. Module: Check the correct operation of the module, for this connect another thermostat and verify that Error 1 does not appear on the screen.
5. Restart the zone and re-associate it with the system:

**Remember:** To reset to factory values of any Lite thermostat, turn up the microswitch 8 and place the thermostat on the base again. Press on , the LED will flash green twice when the reset process is completed.

6. Restart system: If the system is restarted, this error may be displayed in the thermostats at the beginning of the process. This message should disappear after around 30 seconds.

### AZDI6MZZONC / AZDI6MZRSEC / AZDI6MCIFRC

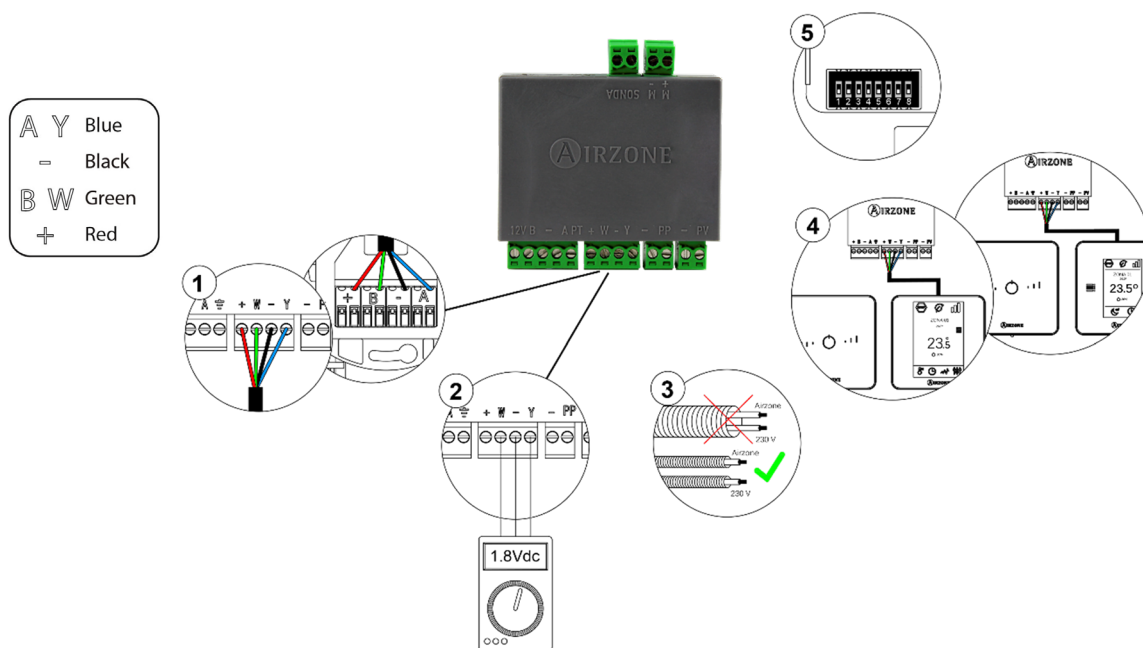



**AZDI6ZMOFANC**

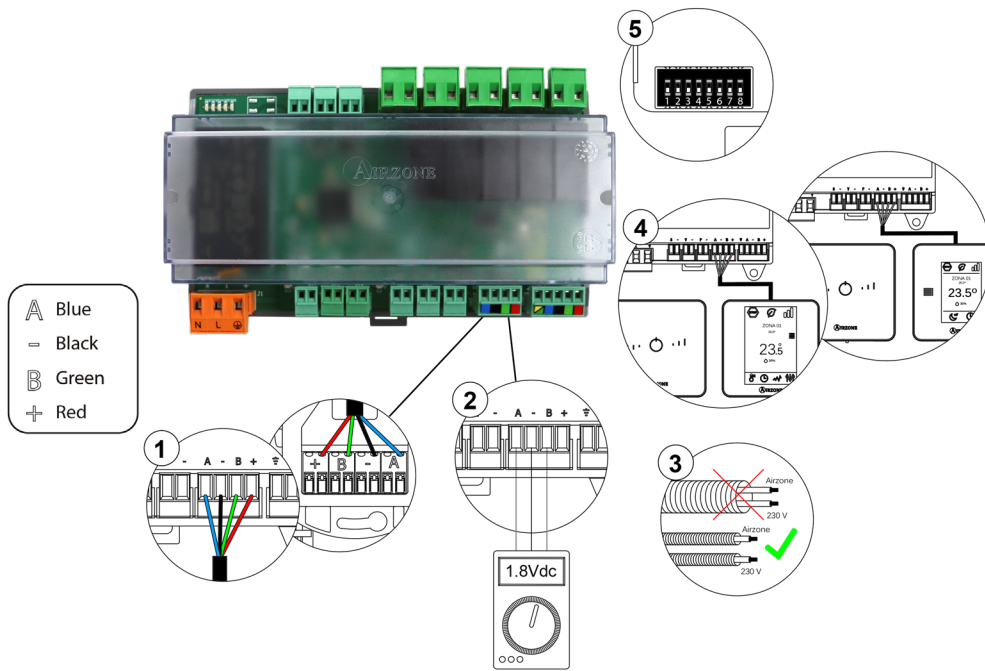

**AZDI6MCxxxC**

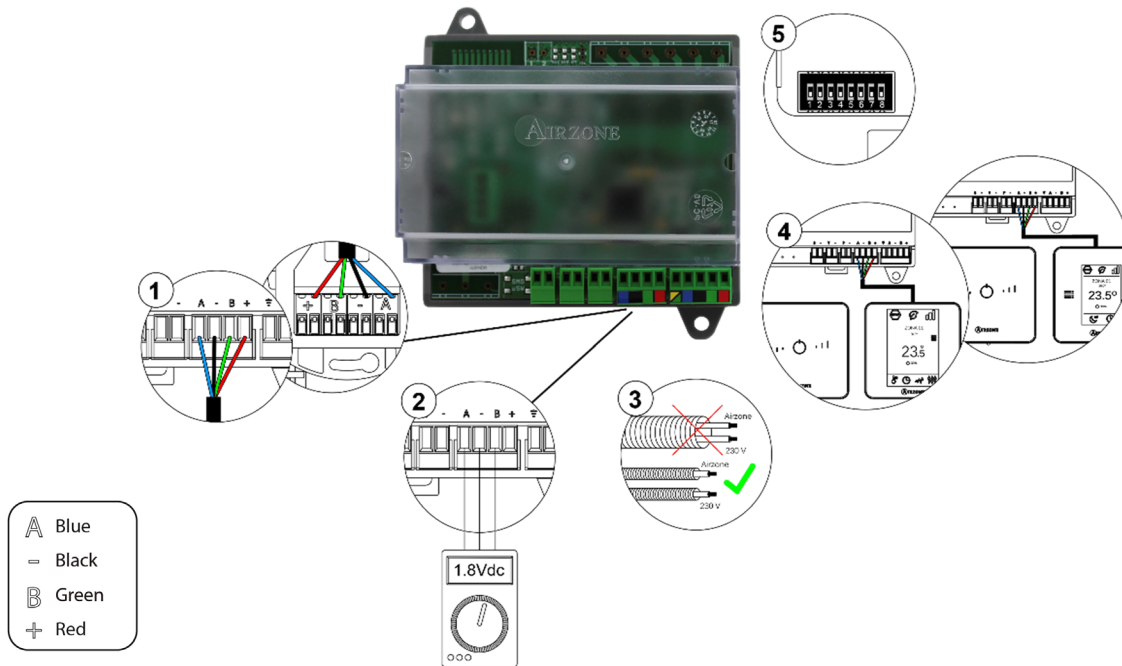

## AZDI6ZMOxxxC

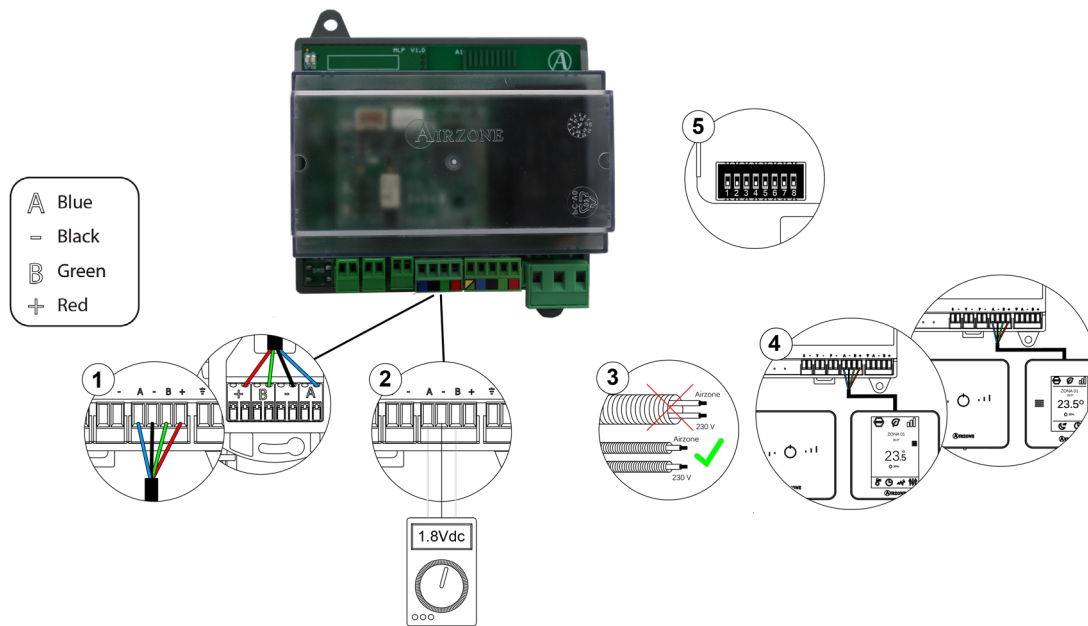

**Status LED blinking purple quickly: Lite thermostat- control module communication error**

**(AZDI6MZZONR / AZDI6MZSRER / AZDI6MCIFRR / AZDI6ZMOFANR / AZDI6MCxxxR)**

This incident blocks the control of the zone. To solve this incident check:

1. Thermostat status: Check the signal range of the thermostat with the module through the Information parameter from remote zones or approach the thermostat to the module if the thermostat recovers the communication, it is necessary to relocate it as it was out of range.
2. Module status: Correctly powered.
3. Module status: Proper operation of the LED of wireless communication.
4. Restart the zone and re-associate it with the system.

**Remember:** To reset to factory values of any Lite thermostat, turn up the microswitch 8 and place the thermostat on the base again. Press on , the LED will flash green twice when the reset process is completed.

5. Restart system: If the system is restarted, this error may be displayed in the thermostats at the beginning of the process. This message should disappear after around 30 seconds.

## AZDI6MZZONR / AZDI6MZSRER / AZDI6MCIFRR

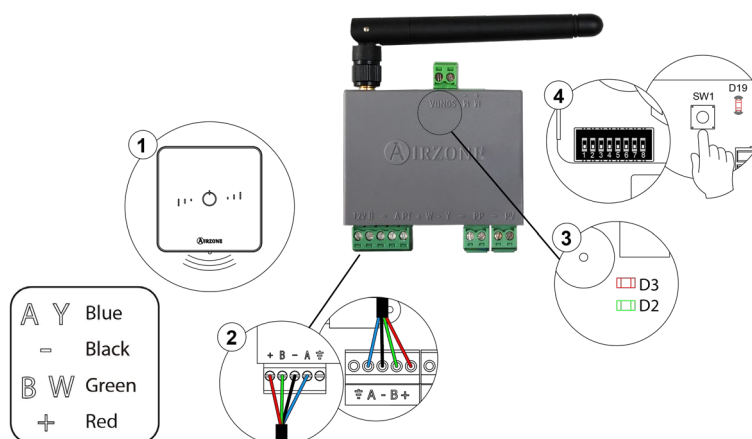



**AZDI6ZMOFANR**

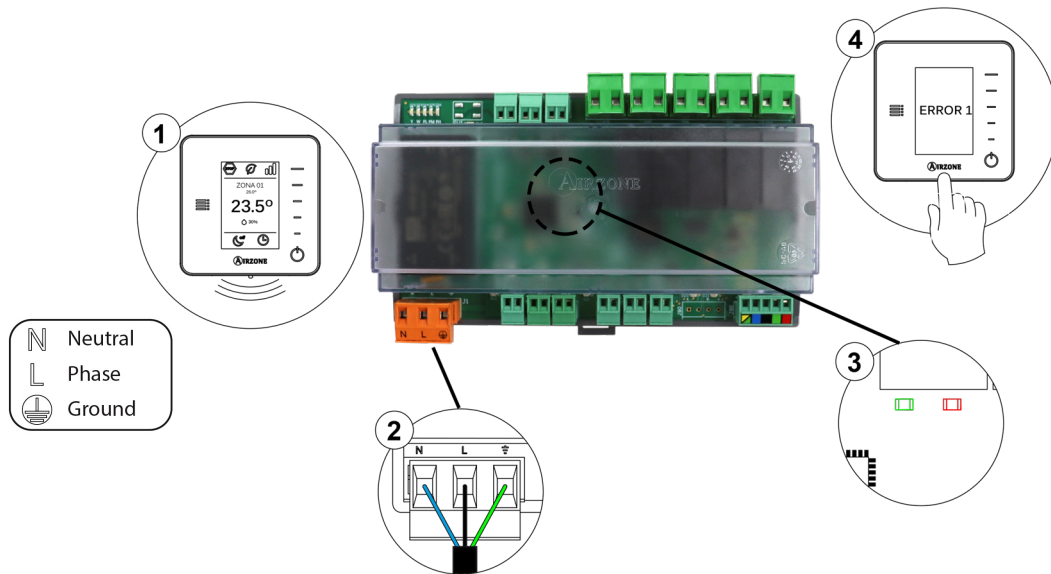

**AZDI6MCxxxR**

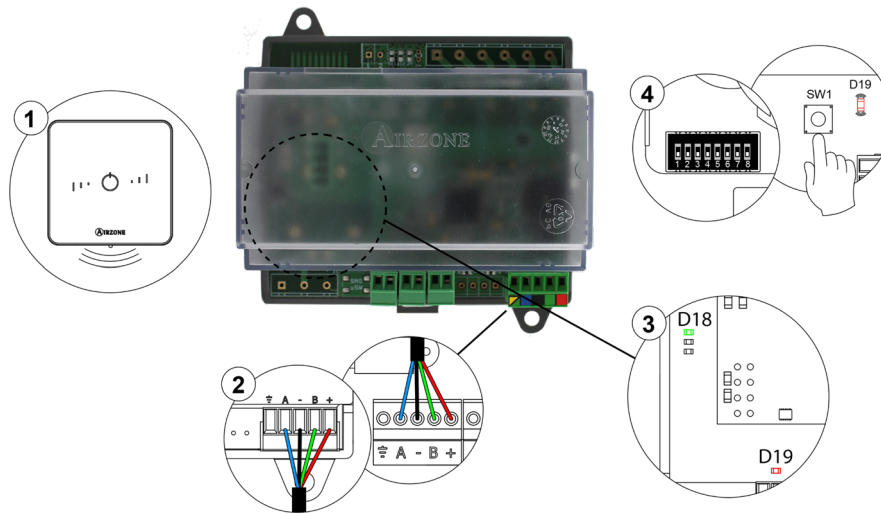

**AZDI6ZMOxxxR**

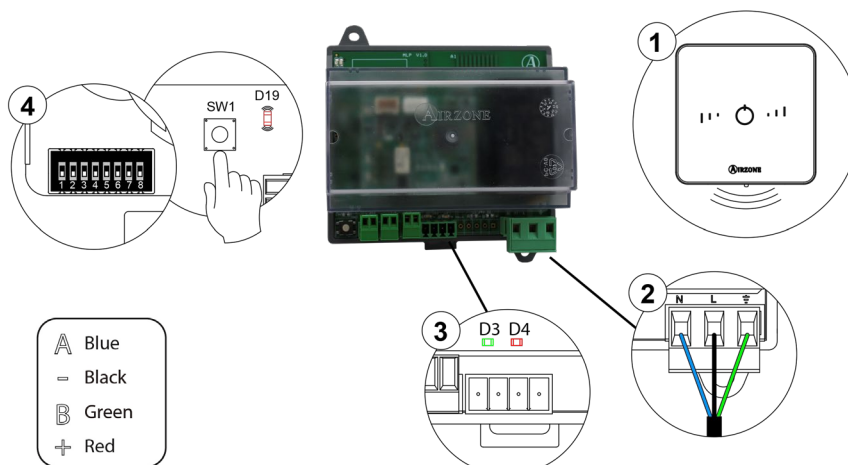

**Status LED  blinking red quickly: control module- main control board communication error (AZDI6MZZON [C/R] / AZDI6MZSRE [C/R] /AZDI6MCIFR [C/R] / AZDI6ZMOFAN [C/R] / AZDI6MCxxx [C/R])**

This incident blocks the control of the zone. Check that “Error 2” 1 does not appear to all thermostats. If so, verify the proper operation of the main board. To solve this incident check:

1. Main control board status: Correctly powered.
2. Main control board status: Airzone Connection Bus LEDs are operating properly.
3. Connection: Verify the polarity of the main control board and thermostat connectors.
4. Wiring: Check that the voltage between the poles (A/ -) and (B/ -) is correct (1.8 Vdc).
5. Restart the zone and re-associate it with the system.

**Remember:** To reset to factory values of any Lite thermostat, turn up the microswitch 8 and place the thermostat on the base again. Press on , the LED will flash green twice when the reset process is completed.

6. Restart system: If the system is restarted, this error may be displayed in the thermostats at the beginning of the process. This message should disappear after around 30 seconds.

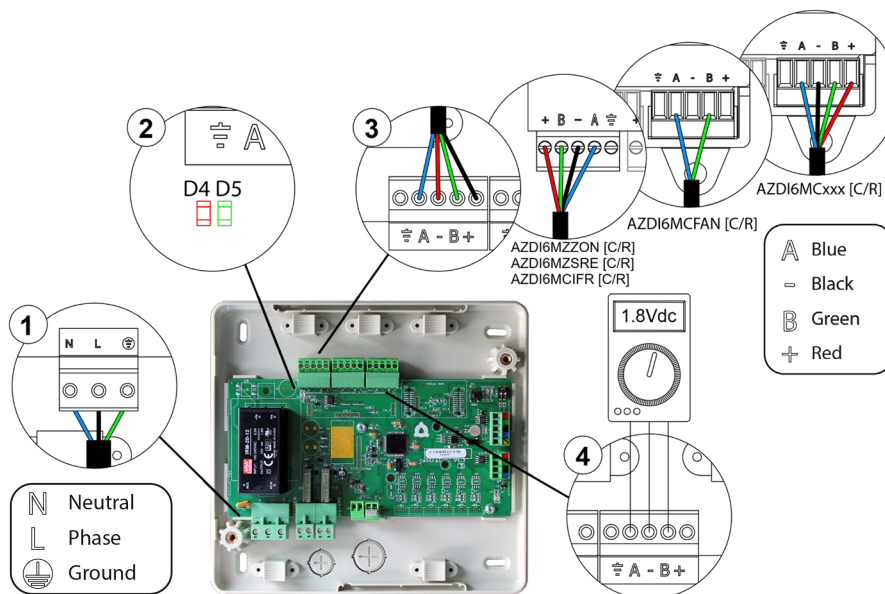

**AIRZONE COMMUNICATION GATEWAYS (AZX6QADAPT XXX)**

Inverter gateways incorporate LEDs that detect unusual operations. Check the distribution of the LEDs in the data sheet supplied along with the product.

- 1) **Power LED D1: Off**
  - Check the air conditioning unit is powered.
  - Check the connections between the gateway and the AC unit and between the gateway and the thermostat of the AC unit (if applicable).
  - Verify the status of the connectors in the wiring connecting gateway-AC unit and/or gateway- AC thermostat.
  - Verify the gateway is properly connected to the AC unit port of the main control board.
- 2) **Microprocessor operation LED D2: Not blinking**
  - Contact the Airzone Technical-Support Department. Your microprocessor does not operate properly.
- 3) **Communication LEDs D3 and D4: Not blinking**
  - Verify the gateway is properly connected to the AC unit port of the main control board.
- 4) **LEDs D5 and D6 of communication with the indoor unit: Not blinking**
  - Check gateway-AC unit connection
- 5) **LEDs D5 and D6 of communication with the indoor unit: Not blinking**
  - Check the Gateway-AC unit thermostat connection.

## CONTROLLER GATEWAY (AZX6GTC XXX) / COMMUNICATION GATEWAY QADAPT 3 (AZX6QADAPT3 XXX)

Controller and communication gateways incorporate LEDs that detect unusual operations

Check the distribution of the LEDs in the data sheet supplied along with the product.

1) **Power LED D11: Off**

- Check the air conditioning unit is powered.
- Check the connections between the gateway and the AC unit and between the gateway and the thermostat of the AC unit (if applicable).
- Verify the status of the connectors in the wiring connecting gateway-AC unit and/or gateway- AC thermostat.
- Verify the gateway is properly connected to the AC unit port of the main control board.

2) **Microprocessor operation LED D3: Not blinking**

- Contact the Airzone Technical-Support Department. Your microprocessor does not operate properly.

3) **Communication LEDs D8 and D9: Not blinking**

- Verify the gateway is properly connected to the AC unit port of the main control board.

4) **LEDs D34 and D35 of communication with the indoor unit: Not blinking**

- Check gateway-AC unit connection.

## AIRZONE 0-10 V FANCOIL CONTROL GATEWAY (AZX6010VOLTSZ)

Airzone 0-10 V Fancoil communication gateways incorporate LEDs that detect malfunctions.

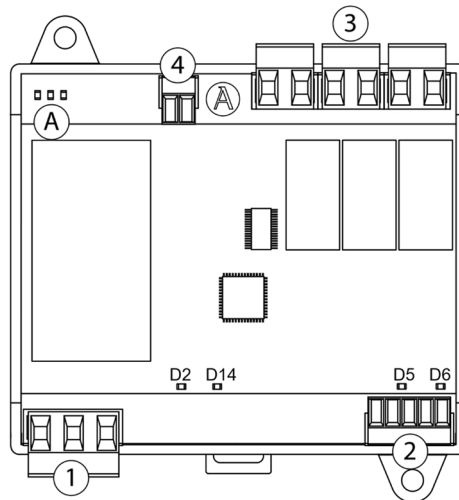

Meaning			
<b>D2</b>	Power supply	Solid	Red
<b>D5</b>	Data reception from AC unit bus	Blinking	Green
<b>D6</b>	Data transmission from AC unit bus	Blinking	Red
<b>D14</b>	Gateway performance	Blinking	Green
<b>A</b>	LEDs of relay state	Blinking	Green

### AIRZONE CONTROL GATEWAY – 3 SPEEDS FANCOIL (AZX6FANCOILZ)

Airzone Fancoil communication gateways incorporate LEDs that detect malfunctions.

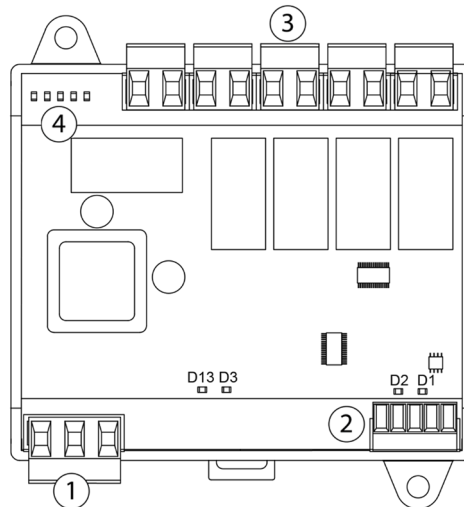

Meaning			
<b>D1</b>	Data reception from AC unit bus	Blinking	Green
<b>D2</b>	Data transmission from AC unit bus	Blinking	Red
<b>D3</b>	Gateway performance	Blinking	Green
<b>D13</b>	Power supply	Steady	Red
<b>(A)</b>	LEDs of relay state	Blinking	Green

### AIRZONE CONTROL GATEWAY FOR ELECTROMECHANICAL UNITS (AZX6ELECTROMECH)

Airzone communication gateways for electromechanical units incorporate LEDs that detect malfunctions.

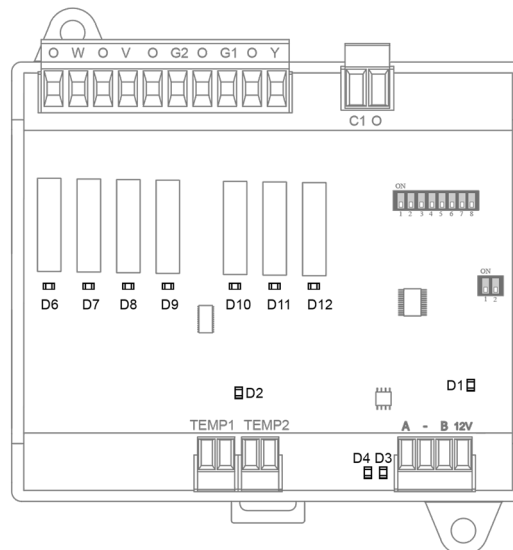

Meaning			
<b>D1</b>	Power supply	Solid	Red
<b>D2</b>	Microprocessor performance	Blinking	Green
<b>D3</b>	Data reception from AC unit bus	Blinking	Green
<b>D4</b>	Data transmission from AC unit bus	Blinking	Red
<b>D6 ... D12</b>	LEDs of relay state	Blinking	Green

### WEBSERVER AIRZONE CLOUD (AZX6WEBSCLLOUDC/AZX6WSC5GER)

Airzone Cloud web servers incorporate LEDs that detect malfunctioning.

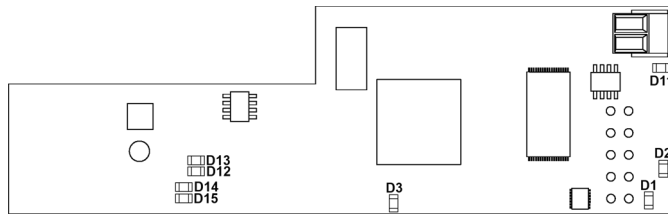

**AZX6WSC5GER**

Meaning			
<b>D1</b>	Data transmission from domotic bus (input and output)	Blinking	Red
<b>D2</b>	Data reception from domotic bus (input and output)	Blinking	Green
<b>D3</b>	Microprocessor performance	Blinking	Green
<b>D10</b>	Connected to the Internet	Blinking	Green
<b>D11</b>	Network data transmission	Blinking	Red
<b>D12</b>	Network data reception	Blinking	Green
<b>D13</b>	Configured as IP address through DHCP	Switch on	Red
	Configured as Fixed IP address	Switch off	
<b>D15</b>	Power supply	Solid	Red

### AIRZONE HYDRONIC PRODUCTION CONTROL BOARD (AZX6CCPGAWI)

Airzone cloud production control board incorporate LEDs that detect malfunctioning.

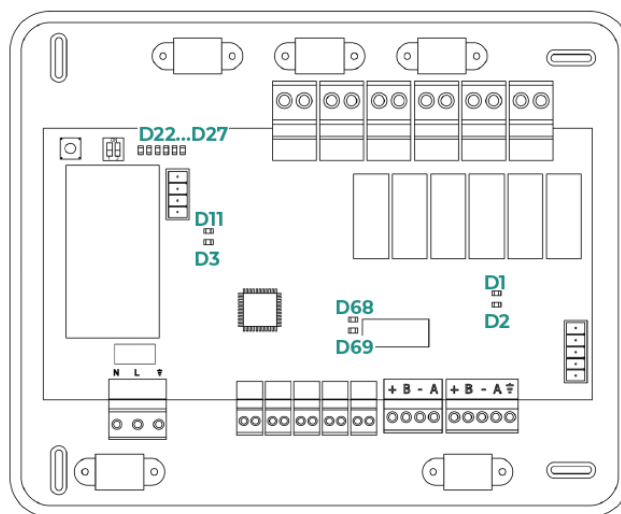

Meaning			
<b>D1</b>	Receiving data from domotic bus	Blinking	Green
<b>D2</b>	Transmitting data from domotic bus	Blinking	Red
<b>D3</b>	Microprocesor performance	Blinking	Green
<b>D11</b>	Power supply	Solid	Red
<b>D22...D27</b>	Leds of relay state	Switches	Green

<b>D68</b>	Data transmission from integration bus	Blinking	Red
<b>D69</b>	Data reception from integration bus	Blinking	Green

### AIRZONE PRODUCTION CONTROL BOARD (AZX6CCP)

Airzone production control boards incorporate LEDs that detect malfunctions.

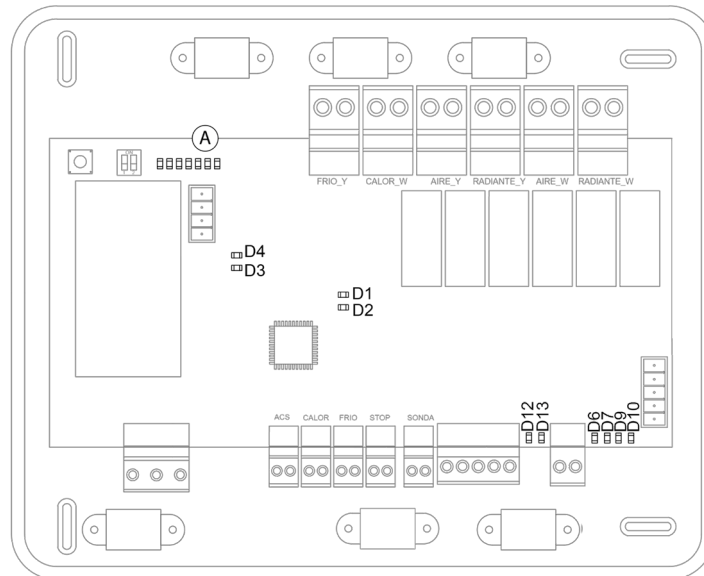

Meaning			
<b>D1</b>	Power supply	Solid	Red
<b>D2</b>	Microswitch performance	Blinking	Green
<b>D3</b>	Data transmission from AC unit bus	Blinking	Red
<b>D4</b>	Data reception from AC unit bus	Blinking	Green
<b>D6</b>	Transmitting data from internal domotic bus	Blinking	Red
<b>D7</b>	Receiving data from internal domotic bus	Blinking	Green
<b>D9</b>	Transmitting data from external domotic bus 1	Blinking	Red
<b>D10</b>	Receiving data from external domotic bus 1	Blinking	Green
<b>D12</b>	Transmitting data from external domotic bus 2	Blinking	Red
<b>D13</b>	Receiving data from external domotic bus 2	Blinking	Green
<b>(A)</b>	LEDs of relay state	Switches	Green

### AIRZONE AEROTHERMAL GATEWAYS (AZX6GAW XXX)

Aerothermal gateways incorporate LEDs that detect unusual operations.

Consult the distribution of the LEDs in the data sheet supplied along with the product.

Meaning			
<b>D3</b>	Micro controller activity	Blinking	Green
<b>D8</b>	Data transmission to the Airzone system	Blinking	Red
<b>D9</b>	Data reception from the Airzone system	Blinking	Green
<b>D11</b>	Gateway power supply	Solid	Red
<b>D34</b>	Data transmission to the indoor unit	Blinking	Red
<b>D35</b>	Data reception from the indoor unit	Blinking	Green



## AIRZONE-KNX INTEGRATION GATEWAY (AZX6KNXGTWAY)

Airzone-KNX integration gateway incorporates LEDs that detect malfunctions.

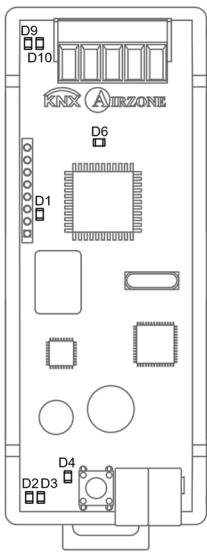

Meaning			
D1	Microswitch performance	Blinking	Green
D2	Data reception from KNX bus	Blinking	Green
D3	Data transmission from KNX bus	Blinking	Red
D4	LED Programming	Solid	Red
D6	Power supply	Solid	Red
D9	Data reception from domotic bus	Blinking	Green
D10	Data transmission from domotic bus	Blinking	Red



# NAVIGATION TREES

## NAVIGATION TREE - BLUEFACE THERMOSTAT

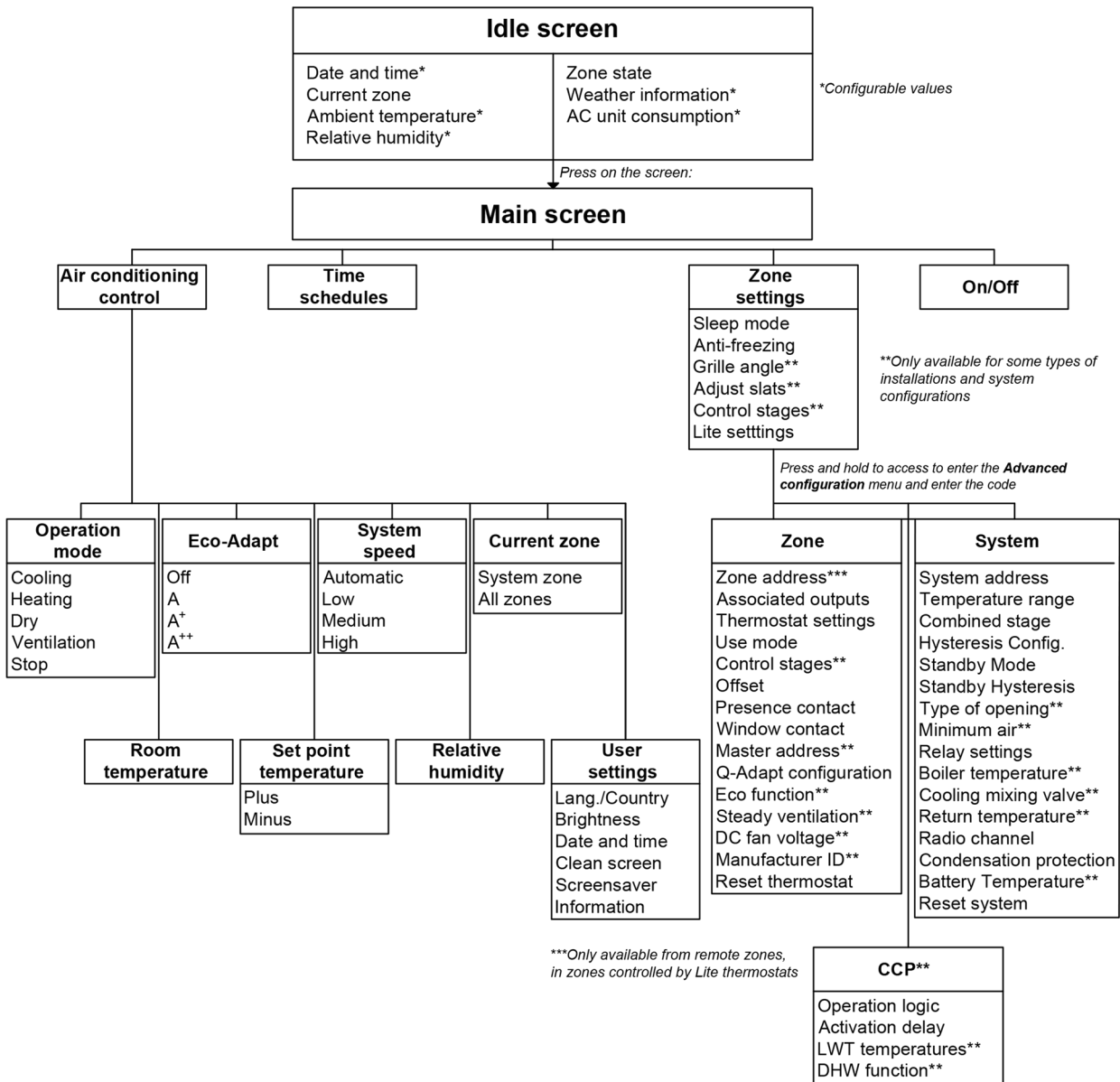
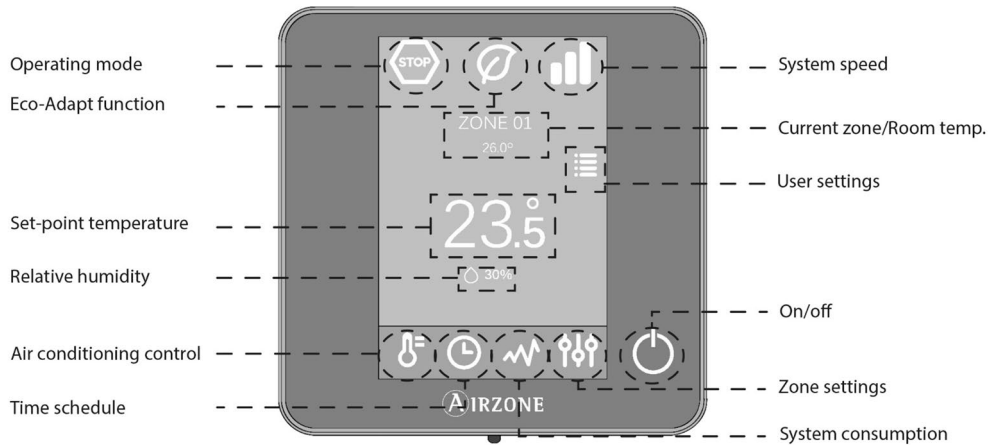

# NAVIGATION TREE - THINK THERMOSTAT

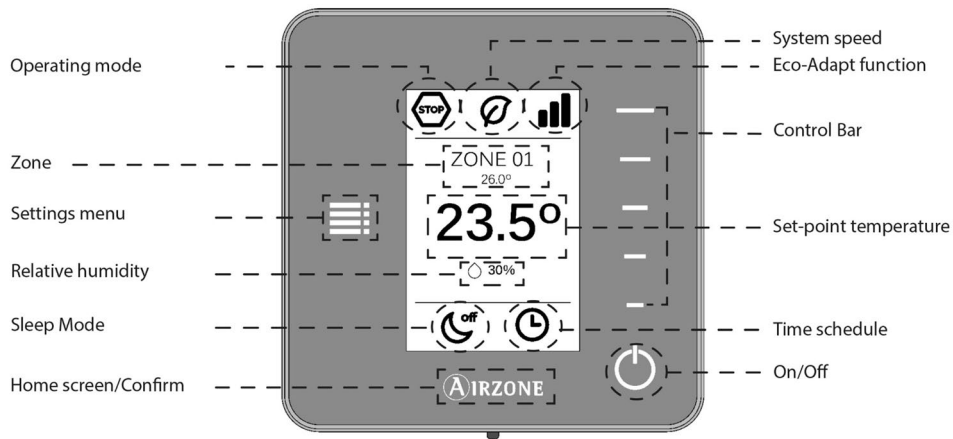

Idle screen	
Date*	Weather information*
Current zone*	Airzone
Zone state	

\*Depending on the devices connected

Press Airzone:

Main screen	
<b>Read-only icons:</b> Operation mode Eco-Adapt System speed Current zone Room temperature Set point temperature Relative humidity Sleep mode Time schedules	<b>Capacitive icons:</b> Settings menu Airzone Control bars On/Off

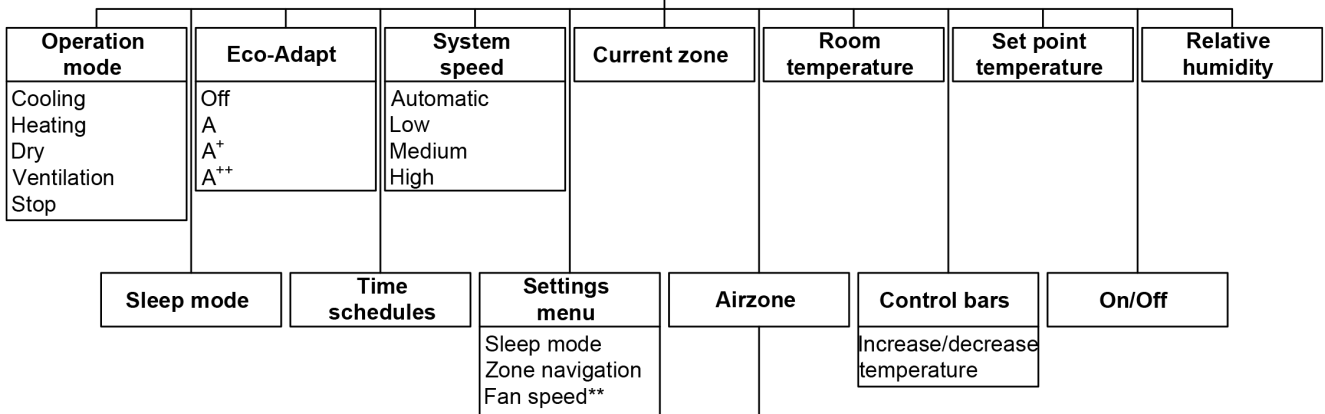

\*\*Only available for some types of installations and system configurations

Press and hold twice on Airzone to enter the advanced configuration menu

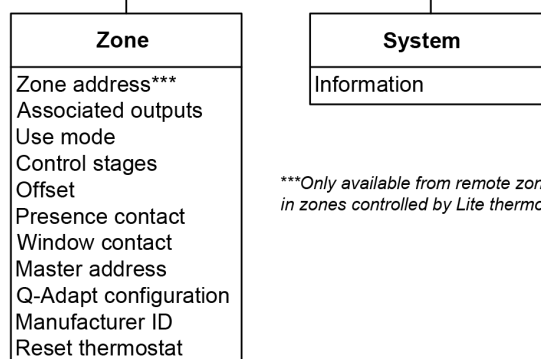

\*\*\*Only available from remote zones, in zones controlled by Lite thermostats



Parque Tecnológico de Andalucía

Marie Curie, 21 - 29590

Campanillas - Malaga (SPAIN)

Teléfono: +34 900 400 445

Fax: +34 902 400 446

<http://www.myzone.airzone.es>

Parc Tertiaire Silic – Inmeuble Panama

45 Rue Villeneuve

94573 Rungis - France

Téléphone: +33 184 884 695

Fax: +33 144 042 114

<http://www.myzone.airzonefrance.fr>

Via Fabio Filzi, 19/E – 20032

Cormano – Milano - Italia

Telefono: +39 02 56814756

Fax: +39 02 56816158

<http://www.myzone.airzoneitalia.it>

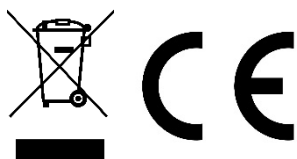

MIAZD16EN108